

**City of Tacoma**

# **Urban Forest Manual**

**Required Landscaping Through Development**



**February 2025**

**Notice:**

This manual was authored by the City of Tacoma Environmental Services and Planning and Development Services Departments, with support provided by Mithun.

City of Tacoma  
Planning and Development Services/Environmental Services  
747 Market Street, 3<sup>rd</sup> Floor  
Tacoma WA 98402

© Copyright 2025 City of Tacoma

All rights reserved. This Manual is intended for use by development and redevelopment project proponents, planners and developers, and by City of Tacoma employees and their designees. This manual may not be reproduced in whole or in part without the written permission from the City of Tacoma.

# Contents

<b>Introduction.....</b>	<b>6</b>
<b>Intent .....</b>	<b>6</b>
<b>Determining Tree and Landscaping Requirements .....</b>	<b>7</b>
<b>Chapter 1 Landscaping Applicability and Types.....</b>	<b>9</b>
<b>Chapter 2 Landscaping Requirements and Standards.....</b>	<b>11</b>
2.1 Guidance to Help Meet TMC Requirements:.....	11
2.2 On-Site Tree Canopy Credits .....	12
2.3 On-Site Tree Retention .....	16
2.4 Street Trees .....	18
2.5 Overall Site Landscaping.....	21
2.6 Site Perimeter Landscaping.....	23
2.7 Parking Lot Landscaping .....	25
2.8 Landscaping Buffers .....	26
2.9 X District Front Yard and Foundation Landscaping .....	27
<b>Chapter 3 Incentives, Flexibility, and Fees .....</b>	<b>28</b>
3.1 Incentives and Flexibility .....	28
3.2 Fees .....	31
<b>Chapter 4 General Planting Standards.....</b>	<b>34</b>
4.1 Plant Quality and Condition.....	34
4.2 Trees .....	35
4.3 Shrubs.....	43
4.4 Groundcover .....	43
<b>Chapter 5 Landscape Plans .....</b>	<b>47</b>
<b>Chapter 6 Landscape Management Plans (LMPs).....</b>	<b>48</b>
6.1 Irrigation Option(s) Selection and Maintenance Schedule.....	49
<b>Chapter 7 Tree Protection During Construction .....</b>	<b>50</b>
7.1 Tree Protection Areas.....	51
7.2 Tree Protection Plans .....	52
7.3 Alternative Tree Protection Plans .....	52
7.4 Tree Protection Fencing .....	52
7.5 Working in the Tree Protection Zone – Protective Measures .....	54
7.6 Working in the Tree Protection Zone – Trenching/Excavation.....	55
7.7 Critical Root Zone – Prohibited Construction Activities .....	56
7.8 Post-Construction Tree Monitoring.....	57

**Glossary ..... 58**

**Appendices ..... 64**

Appendix 1	Landscaping Calculations Worksheets: Summary
Appendix 1A	Overall Site Landscaping Calculations Worksheet
Appendix 1B	Site Perimeter Landscaping Calculation Worksheet
Appendix 1C	Parking Lot Landscaping Calculation Worksheet
Appendix 1D	Landscape Buffer Calculation Worksheet
Appendix 1E	X District Front Yard and Foundation Landscaping Calculation Worksheet
Appendix 1F	Required Tree Canopy Credits Worksheet (UR Zones)
Appendix 2	Sample Landscaping Plan
Appendix 3	Landscape Management Plan (LMP) Template
Appendix 4	Sample Tree Protection Plan and Sample Arborist Report
Appendix 5	Tree Protection Zone Sign – General
Appendix 6	Tree Protection Zone Sign – For Trees in Paved Areas
Appendix 7	Tree Lists
Appendix 7A	Approved Large Tree List
Appendix 7B	Approved Medium Tree List
Appendix 7C	Approved Small Tree List
Appendix 7D	Prohibited and Not Recommended Tree List
Appendix 8	Urban Residential Tree Requirements Summary
Appendix 9	Urban Residential Case Study
Appendix 10	Plan Submittal Checklist

## Figures

Chapter 1	Figure 1-1: Tree and Landscaping Requirements Overview - All Zones .....	10
Chapter 2	Figure 2-1: On-Site Tree Canopy Credit Overview – All Zones .....	12
	Figure 2-2: On-Site Tree Canopy Credit Standard – Illustrated .....	13
	Figure 2-3: Tree Canopy Credits for New Trees .....	14
	Figure 2-4: Tree Canopy Credits for Retained Trees.....	14
	Figure 2-5: On Site Tree Retention and Removal Requirements - All Zones.....	16
	Figure 2-6: Tree Retention Standards in UR Zones .....	17
	Figure 2-7: Street Tree Requirements Overview - All Zones.....	19
	Figure 2-8: Street Tree Calculation.....	20
	Figure 2-9: Overall Site Landscaping Requirements Overview - All Zones.....	22
	Figure 2-10: Site Perimeter Landscaping Requirements Overview - All Zones.....	23
	Figure 2-11: Parking Lot Landscaping Tree Requirements - All Zones.....	25
Chapter 3	Figure 3-1: Calculating Linear Feet above Requirements .....	28
	Figure 3-2: Linear Feet and Tree Canopy Credit Equivalent.....	29
	Figure 3-3: Canopy Loss Fees for Removal of Trees 18” DBH or Larger .....	31
	Figure 3-4: Canopy Loss Fee for Removal of Trees 6” to 18” DBH .....	32
	Figure 3-5: Current Tree Canopy Credit Fee is \$15 per Tree Canopy Credit .....	33
Chapter 4	Figure 4-1: Tree Placement in Bulb-Outs .....	38
	Figure 4-2: Tree Placement in Medians and Converted Parking Spaces.....	38
	Figure 4-3: Tree Placement Under Overhead Utilities .....	39
	Figure 4-4: Soil Standards .....	40
	Figure 4-5: Multiple Ways to Achieve Required Soil Volume .....	40
	Figure 4-6: Treatment of Unpaved Planting Areas .....	41
	Figure 4-7: Minimum Spacing Standards for Trees (OC) .....	41
	Figure 4-8: Minimum Tree Setbacks .....	42
	Figure 4-9: Minimum Tree Clearances (at Maturity).....	42
	Figure 4-10: Groundcover Spacing Standards.....	44
	Figure 4-11: Plant Quantities per 100 sq ft.....	45
	Figure 4-12: Groundcover Planting Spacing Example .....	46
Chapter 7	Figure 7-1: Tree Protection Areas .....	51

## Introduction

The Urban Forest Manual (UFM) is a guide created to facilitate the planning, design, installation and maintenance of trees and landscaping required for new development and redevelopment per the City of Tacoma's (City) Tacoma Municipal Code (TMC) 13.06.090B Landscaping Standards and other applicable portions of the Zoning Code (TMC 13.06). It is intended to be used concurrently with TMC 13.06.090B to ensure the requirements and standards are executed properly. Before finalizing development plans, visit the Planning and Development Services (PDS) website at [www.tacomapermits.org](http://www.tacomapermits.org), contact the permit center at (253) 591-5030, or visit them at 747 Market Street on the third floor, to verify that all other applicable City codes and manuals have been met.

## Intent

The City's landscaping requirements are intended to contribute to the aesthetic environment of the City and provide an attractive urban setting to enhance livability and foster economic development. These requirements also provide green spaces that can support the citywide tree canopy goal of 30 percent, support wildlife in the urban environment, and help reduce storm water runoff, filter pollution, and reduce the urban heat island effect. These landscaping requirements also buffer and soften the visual impacts of development, and support the planting, maintenance, and preservation of a stable and sustainable urban forest.

TMC 13.06.090B helps to support this intent by requiring landscaping (trees, shrubs and groundcover) be installed when significant development activities take place. In crafting TMC 13.06.090B, the City sought to achieve these objectives in a flexible manner that balances urban density development activities with livability and community health. Landscaping requirements generally apply to new construction and substantial alterations of structures, parking areas, streets, and sidewalks. Minor alterations are exempt from landscaping requirements, except for street tree requirements triggered by off-site improvements as specified in [Section 2.4](#). The TMC also contains a range of options intended to provide flexibility while still meeting the intent, as well as incentives for inclusion of desired features like saving mature trees, and planting larger tree species, native plants, and Low Impact Development stormwater facilities.

When required, landscaping must comply with the TMC and this UFM's standards for plant selection, installation, and maintenance. These standards are intended to better ensure plants survive and thrive, to minimize conflicts with infrastructure, and in some cases to provide a substantial visual buffer. Generally, landscaping plans and management plans detailing how landscaping will be maintained must be prepared by a professional. TMC 13.06.090B also references the UFM as a source of additional guidance on the technical aspects of landscaping. However, please note that TMC 13.06.090B is the prevailing source of regulatory authority and shall prevail if conflicts arise between TMC and landscaping requirements as defined in this Manual.

In certain instances, other City codes may require or pertain to landscaping. Additional landscaping requirements, erosion control, and other stormwater related measures are contained in the City’s Stormwater Management Manual available online at [cityoftacoma.org/stormwatermanual](http://cityoftacoma.org/stormwatermanual). For tree planting, pruning, and removal on public lands, including the right-of-way and public property, refer to TMC Title 9.20 Urban Forestry, in addition to the requirements contained in this UFM. For tree and landscaping requirements within a regulated Critical Area, refer to TMC Title 13.11 Critical Areas Preservation.

## Determining Tree and Landscaping Requirements

The UFM is organized to guide users in determining if and how landscaping is required in association with development activities. The following steps are recommended:

1. Determine the specific zoning designation for the property you are intending to develop or redevelop.

*Tree and landscaping requirements for all zones, including Urban Residential (UR) zones, are contained in **Chapter 2**. Refer to TMC 13.06.090B and Figure 1-1 Tree and Landscaping Requirements Overview of the general landscaping requirements of Chapter 2.*

2. Determine if your proposed development will trigger landscaping requirements, and which ones apply.

***Chapter 1** of the UFM provides an overview of the City’s landscaping requirements and an indication of when they typically apply. It is intended to be used in conjunction with TMC 13.06.090B.*

3. If landscaping is required, determine how much and what type is required.

***Chapter 2** of the UFM includes a landscaping requirements table, for use in determining how much landscaping will be required, based on the location, scope and type of development activities.*

*In addition, UFM **Chapter 3** provides guidance on determining whether landscaping features eligible for incentives or bonuses under the landscaping code may reduce the amount of required landscaping or provide flexibility on planting location.*

4. Determine if tree protection requirements apply to your site

*If developing or redeveloping in UR1, UR2, or UR3 zones, and **there are existing trees on your site**, you will need to prepare the required existing tree inventory along with arborist report and tree protection plan, as applicable, in compliance with **Chapter 7**.*

5. Determine requirements intended to ensure that landscaping survives and thrives.

***Chapter 4** of the UFM provides guidance on planting and installation.*

6. Based on the landscaping that is required and how it should be selected and cared for, prepare your application for submittal with your building or site development permit. To enable staff to determine that your proposed landscaping meets the TMC, the following items are required for submittal:

- *Landscaping Requirements Table* – discussed in **Chapter 2** and provided in Appendix 1.
- *Landscape Plan* – refer to **Chapter 5** and Appendix 2.
- *Landscape Management Plan* – refer to **Chapter 6** and Appendix 3.
- *Tree Protection Plan and Arborist Report (if retaining vegetation)* – refer to **Chapter 7** and Appendix 4.

7. After submittal, City staff will guide you through the review and approval process.

*Once construction permits are issued, landscaping is required to be installed (or bonded for) in accordance with the approved plans and pertinent TMC requirements. Ongoing maintenance and replacement of required landscaping is the responsibility of the property owner.*

## Chapter 1 Landscaping Applicability and Types

Use this chapter, along with TMC 13.06.090B, to determine if your development triggers landscaping requirements, and to determine which ones apply. Consult a PDS Planner to discuss any questions or concerns.

1. Does the landscaping code apply to what I am doing?

*Landscaping is required for new development and substantial alterations as laid out in the TMC. When modifying landscaping for an existing development, the property is required to be “no less non-conforming” with the requirements of the current TMC. In addition, street trees are also required with the construction of new permanent roadways, alterations to the width of existing permanent roadways, construction of new sidewalk, and replacement of more than 50% of an existing sidewalk along a site’s frontage (when 50 linear feet or more is being constructed).*

2. Is my development exempt from landscaping?

*The on-site portions of the following are exempt from on-site landscaping requirements, except for street tree requirements as specified in [Section 2.4 Street Trees](#), and parking lot requirements as specified in [Section 2.7 Parking Lot Landscaping](#):*

- *Passive open space areas*
- *Park and recreation uses*

*See TMC 13.06.020, 13.06.030, 13.06.060, and 13.06.040 for specific Landscaping requirements and any exemptions applicable to Urban Residential, Residential, Commercial, Industrial and Mixed-Use Districts.*

3. If landscaping is required, review Figure 1 *Tree and Landscaping Requirements Overview - All Zones* below, accompanied by TMC 13.06.090B to determine which of the following applies:

- *On-Site Tree Canopy Credits*
- *On-Site Tree Retention*
- *Required Street Trees*
- *Overall Site Landscaping*
- *Site Perimeter Landscaping*
- *Parking Lot Landscaping*
- *Landscaping Buffers*
- *X District Front Yard and Foundation Landscaping*

Figure 1-1: Tree and Landscaping Requirements Overview - All Zones

Zone Name	UR-1	UR-2	UR-3	R-4	R-5	T	C-1	C-2	PDB	M-1	M-2	PMI	X Dist.
<b>On Site Tree Canopy/ Credits</b>	New development & substantial alterations			New development & substantial alterations		Single-use residential development and multi-unit residential development with a commercial component, only				Residential uses only		N/A	
<b>On Site Tree Retention Requirement</b>	All development			Critical Areas only									
<b>Street Trees</b>	New development; substantial alterations; new roadways; alterations to width of existing roadways; new sidewalk; and replacement of more than 50% of sidewalk along a site's frontage											*Refer to Standard Section	Required
<b>Overall Site Landscaping</b>	New development & substantial alterations									Applies to percent of parking areas over 20,000sf		Single-purpose residential projects	
<b>Site Perimeter</b>	N/A			Required						N/A		N/A	
<b>Parking Lot Landscaping</b>	Overall Site, Distribution, & Interior; Perimeter only required between lots and streets. Exceptions apply to lots with less than 16 stalls.			Overall Site, Distribution, Perimeter, & Interior. Exceptions apply to lots with less than 16 stalls.									
<b>Landscaping Buffer</b>	Applies when abutting dissimilar district.												
<b>Front Yard &amp; Foundation Landscaping</b>	N/A											Required	

\*Specific standards apply to Zone; refer to Standards Section to determine any applicable modifications or exemptions.

\*\* For developments within Downtown Tacoma, refer to TMC 13.06.050 Downtown Tacoma for requirements in addition to Zone standards.

## Chapter 2 Landscaping Requirements and Standards

Use this chapter, in association with the landscaping requirements table in TMC 13.06.090.B, to determine how much landscaping is required based on the location, scope and type of development activities. To confirm how landscape requirements apply to each zone, reference *Figure 1-1: Tree and Landscaping Requirements Overview - All Zones*.

Zone-specific requirements and worksheets are listed in Appendices 1 and 8.

### 2.1 Guidance to Help Meet TMC Requirements:

- The TMC contains both numerical and distribution requirements. Each project must provide landscaping to satisfy the most stringent of the numerical or distribution requirements. The following worksheets are intended as an aid in calculating the total number of trees required under each applicable landscaping type. The tables included in Sections 2.2 through 2.7 are for use in aiding the applicant to determine their requirements and are not required for permit submittal.
- In some cases, landscaping may count towards fulfillment of more than one requirement. For example, Overall Site Landscaping is often met by other requirements, such as Site Perimeter, Parking Lot distribution and Buffer landscaping.
- Flexibility, described in Chapter 3, includes alternative options for meeting landscaping requirements. For example, trees planted in the right-of-way above those required by the TMC can apply credits toward onsite tree canopy credits. Review the flexibility options to determine if any apply.
- Tree planting requirements are determined based on tree species Canopy Factor (mature height, crown spread and growth rate). For each landscaping type that requires trees, the number required is a sliding scale with the most required when small tree species are planted, and least when large tree species are planted. Small, medium and large tree species may be used in combination. See Appendix 7 for a list of tree species' Canopy Factors.
- Unique circumstances such as wetlands, steep slopes, habitat corridors or an area specific landscape plan may affect landscaping requirements. To find out additional information on constraints or to see if an area specific landscape plan exists, schedule a pre-application meeting with Planning Development services.
- The summary table included as Appendix 1 is to be filled out and submitted as part of the permit application submittal.
- Applicants should see Appendix 10 for a plan submittal checklist to assist in permit application processes.

## 2.2 On-Site Tree Canopy Credits

Trees are an integral part of our communities and the ecological systems in which they exist. They provide significant economic, social and ecological benefits, such as carbon sequestration, reduction of the urban heat island effect, energy savings, reduction of stormwater runoff, improvement of water quality, psychological healing and calming qualities and increased value of business and residential properties. Trees are as necessary as water, infrastructure, and energy to sustaining healthy communities and the health of the urban forest is directly linked to the health of the Puget Sound.

Figure 2-1: On-Site Tree Canopy Credit Overview – All Zones

Zone Name	UR-1	UR-2	UR-3	R-4	R-5	T	C-1	C-2	PDB	M-1	M-2	PMI
<b>Applicability</b>	New development; substantial alterations			New development; substantial alterations		Applies to single-use residential development and multi-unit residential development with a commercial component, only.				Applies to residential uses only, R-4 District canopy percentage applies [13.06.020]		
<b>Tree Credits/ Canopy cover</b>	30%	25%	20%	20%	15%	30%	30%	20%	20%	20%	20%	20%
<b>Calculating Tree Credits</b>	13.06.090.B.3.e(2)											
<b>Tree Credit Minimums with Bonuses</b>	Bonus 1: 25% ----- Bonus 2: 20%	Bonus 1: 20% ----- Bonus 2: 15%	Bonus 1: 15% ----- Bonus 2: 10%									
<b>Tree Credit Floor</b>	10%	10%	10%									
<b>In-lieu/ Tree Credit Fee</b>	Allowed per UFM at 1.5x cost to purchase, plant, and maintain trees; Can only apply tree credit fees above tree credit floor.			Allowed per UFM at 1.5x cost to purchase, plant, and maintain trees								
<b>Landscape Plans &amp; LMPs</b>	Landscape Plan required for all tree planting; Landscape Management Plan required for planting ≥10 trees.											
<b>Exemptions/ Flexibilities</b>	No Tree Credit In-Lieu Fee for qualifying Ownership Opportunity & Accessory Dwelling Unit Incentive; Passive Open Space areas exempt			Passive Open Space areas exempt		Passive Open Space areas exempt				Passive Open Space areas exempt		

## 2.2.1 Applicability

Planting and maintaining trees helps a city become more sustainable and offset the negative impacts on the ecosystem from urban development. Therefore, tree canopy is required in specific zones in order to protect our urban forest and the benefits that it provides. Tree canopy credits are required in accordance with Figure 2-1 above, as adopted in the following TMC Sections:

- TMC 13.06.020.F for Urban Residential (UR1, UR-2 and UR-3)
- TMC 13.06.020.G for Residential (R-4 and R-5)
- TMC 13.06.030.F for Commercial Districts
- TMC 13.06.060.G for Residential Uses in Industrial Districts

## 2.2.2 On-Site Tree Canopy Credit Standard

Not all trees offer the same amount of benefit, and therefore Tree Canopy Credits are determined based on the tree size at maturity to quantify the value of a tree's canopy for the purposes of defining how many trees are required on a site. While existing mature trees provide benefits today, new trees provide value in the future, which increases as they mature. Therefore, trees are allocated credit based on their species size category (for new trees) or DBH (for existing trees). When combined, the total credits of retained trees and new trees on a site must be equal to or greater than the number of required tree canopy credits.

Figure 2-2: On-Site Tree Canopy Credit Standard – Illustrated

District Standards define the percentage of lot area that is used to determine how many trees or "tree credits" are required on a site.

Both existing trees and new small, medium, and large trees are each worth a certain amount of credit toward this target area.

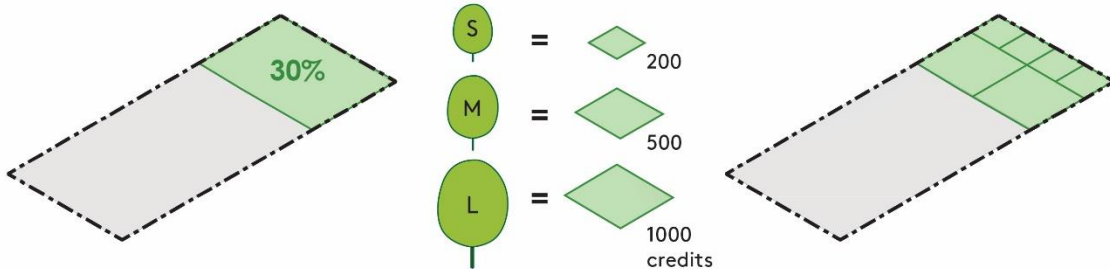

Together, these tree credit requirements work toward a Citywide tree canopy goal of 30%. However, 30% tree canopy coverage does not mean 30% of a lot is reserved for trees.

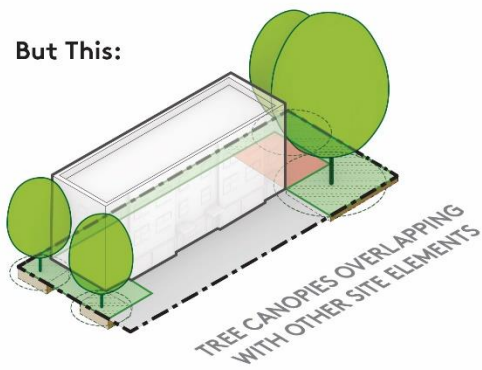
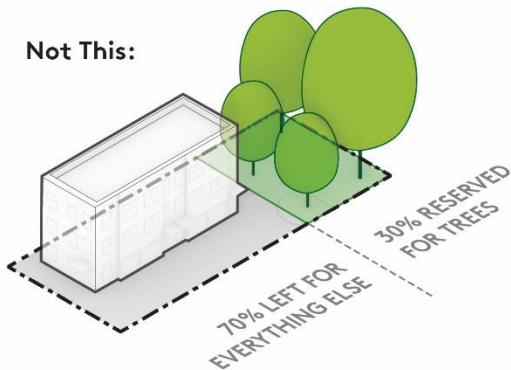

On-site tree canopy credits are required based on the lot area of the site being developed at the percentage defined in Figure 2-1 above.

*Example:*

*A 6,000 square foot lot in a district requiring 30% tree canopy credits would be required to provide 1,800 tree canopy credits. (6,000sf x 0.30 = 1,800 tree canopy credits)*

### 2.2.3 Credits for New Trees

Tree Canopy Credits for new on-site trees are allocated according to species designation as Small, Medium and Large. Reference Appendices 7A, 7B, and 7C for pre-approved tree lists by Size Category, and Appendix 7D for a list of prohibited species that are not eligible for Tree Canopy Credit and should not be planted.

Figure 2-3: Tree Canopy Credits for New Trees

	Small Trees	Medium Trees	Large Trees
<b>Tree Canopy Credits for New Trees</b>	200 credits	500 credits	1,000 credits

### 2.2.4 Credits for Retained Trees

If protected properly, trees retained through development offer more immediate benefits to the urban forest than newly transplanted trees. Therefore, tree retention is a priority, and an incentivized credit is offered for retained trees to reflect this priority. To receive credit, trees must be healthy and have minimal serious defects. Proper pruning to mitigate minor defects may be indicated on the Arborist Report and Tree Protection Plan if applicable.

The size of an existing tree is the best way to represent the benefit it offers. Therefore, credit for qualifying retained trees will be given according to size represented by a tree’s trunk diameter (DBH), according to the table below:

Figure 2-4: Tree Canopy Credits for Retained Trees

	Trees less than 6” DBH	Trees 6” ≤ 12” DBH	Trees 12” ≤ 24” DBH	Trees over 24” DBH
<b>Tree Canopy Credit for Retained Trees<sup>1</sup></b>	50 credits per inch DBH	75 credits per inch DBH	100 credits per inch DBH	125 credits per inch DBH

<sup>1</sup> Any healthy retained tree of at least 2” DBH is worth not less than the tree canopy credits offered for a new tree of that species in accordance with its designation as small, medium, or large per TMC 13.06.090.B.3.e.(2)(c).

*Example:*

- *A retained 17” DBH tree would be worth 1,700 tree canopy credits (17” x 100 credits per inch = 1,700 credits).*
- *A retained 3” DBH “small tree” species would be worth 200 credits (3” x 50 credits per inch = 150 credits). With 200 credits offered for a small species of tree, the minimum of 200 credits applies.*

The Tree Canopy Credits for existing trees are contingent on tree health, and require a Certified Arborist’s Report to determine that the tree(s) is healthy and can be saved through construction activities. If retained trees are damaged during or after construction, replacement trees must meet the required Tree Canopy Credits and any applicable Canopy Loss Fees shall be assessed. If trees are being retained for credit, a Certified Arborist’s Report (Appendix 4) and Tree Protection Plan (TPP) shall be submitted. The TPP shall be consistent with the requirements outlined in Chapter 7 of this volume and should clearly show existing trees, existing and proposed grading, new development on the site (such as buildings, utilities, etc.), measures taken to protect existing trees and any new trees that will be planted on the site. Trees must be healthy or have minimal defects that can be mitigated by proper pruning, as indicated on the Arborist Report and TPP.

To facilitate and incentivize retention of mature trees, additional flexibility is available for parking requirements and parking lot distribution requirements per TMC 13.06.090.B.4.g.(6) and building standards per TMC 13.06.020.F.3 Flexibility for Tree Retention in UR Districts.

NOTE: Species considered invasive or ecosystem nuisances including, but not limited to, the trees listed in [Section 4.2.2 Tree Selection and Species Diversity](#) and those on Appendix 7D - Prohibited Tree List shall not count toward meeting required plantings. Noxious weeds and weeds listed as Class A, B, or C as determined by the Pierce County Noxious Weed Control Board, are prohibited from being planted in required landscaped areas.

## **2.2.5 Exemptions and Modifications to On-Site Tree Canopy Credit Standards**

### *Urban Residential (UR-1, UR-2, and UR-3) Zones*

#### *Flexibility for Multiple Adjoining Parcels*

Multiple adjoining parcels under the same ownership may be combined for the purposes of calculating and meeting required on-site Tree Canopy Credits. The combined lot area must be used to determine required credits. Trees may be planted on a single lot or combination of lots to reach the total Tree Canopy Credits required for all lots. The City may require legal property restrictions to ensure the required trees are protected.

#### *Bonuses for Dedicated Affordability and Retention of Existing Buildings*

Within UR Districts, bonus provisions allow for more flexible on-site tree canopy credit standards in exchange for specified public benefits, including dedicated affordability or retention of existing buildings while adding additional dwellings to a lot. Per TMC 13.06.020.F.2, the bonuses are offered in two tiers, corresponding to the specific public benefits being provided.

### X Districts, Industrial, and Commercial Districts

There is no specific on-site Tree Canopy Credit requirement in X Districts. In T, C-1, C-2, and PDB zones, on-site Tree Canopy Credit requirements apply to single-use residential development and multi-family residential development with a commercial component, only. In M-1, M-2, and PMI zones, on-site Tree Canopy Credit requirements apply to residential uses, and shall meet the tree canopy coverage requirements in 13.06.020 in accordance with the R-4 District.

## 2.3 On-Site Tree Retention

Trees provide more services as they mature, helping to reduce urban heat island, manage stormwater, provide habitat, and improve air quality. If protected properly, trees retained through development offer more immediate benefits to the urban forest than newly transplanted trees. Therefore, tree retention is a priority, and in some zones tree retention is required to reflect this priority.

Figure 2-5: On Site Tree Retention and Removal Requirements - All Zones

Zone Name	UR-1	UR-2	UR-3	R-4	R-5	Commercial	Industrial	X District
<b>Applicability</b>	All development			N/A outside of Regulated Critical Areas	N/A outside of Regulated Critical Areas	N/A outside of Regulated Critical Areas	N/A outside of Regulated Critical Areas	N/A outside of Regulated Critical Areas
<b>Requirements Referenced</b>	13.06.090.B.3.e(3)							
<b>Standard ≥24" DBH</b>	May <b>not</b> be removed, unless significantly limits reasonable development; subject to Canopy Loss Fee regardless of compliance with on-site Tree Credits							
<b>Standard 6" - 18" DBH</b>	May be removed; subject to Canopy Loss Fee regardless of compliance with on-site Tree Credits							
<b>Standard 6" - 18" DBH</b>	May be removed; any removal that brings the on-site Tree Credits below required amount is subject to Canopy Loss Fee							
<b>Standard &lt;6" DBH</b>	Not regulated							
<b>Canopy Loss Fee</b>	Cost-per-inch of DBH removed							
<b>Exemptions/ Flexibilities</b>	Hazard Trees, Significantly Damaged Trees, Fruit Trees, and Trees Damaging Infrastructure are exempt from Retention Requirements			Exempt	Exempt	Exempt	Exempt	Exempt

### 2.3.1 Applicability

#### Urban Residential (UR-1, UR-2, and UR-3) Zones

Tree retention is regulated for all development in Urban Residential (UR) zones. Trees less than 6” in DBH are not regulated unless they are required in compliance with the requirements of TMC (e.g. trees used for required Tree Canopy Credits may not be removed).

#### All Other (Not Urban Residential) Zones

On-site Trees in all other zones are not regulated for tree retention, unless Critical Areas Preservation regulations apply under TMC 13.11. Tree retention off site within the public right of way is regulated under TMC 9.20 Urban Forestry.

### 2.3.2 On-Site Tree Retention Standard in UR Zones

Because of the increased benefits existing trees provide over newly planted trees, on-site tree removal is regulated based on tree size (DBH) as follows:

Figure 2-6: Tree Retention Standards in UR Zones

Tree Size	Retention Requirement
Trees ≥ 24” DBH	May <b>not</b> be removed, unless significantly limits reasonable development; subject to Canopy Loss Fee <sup>1</sup> regardless of compliance with on-site Tree Credits
Trees 18” – 24” DBH	May be removed; subject to Canopy Loss Fee regardless of compliance with on-site Tree Credits
Trees 6” – 18” DBH	May be removed; any removal that brings the on-site Tree Credits below required amount is subject to Canopy Loss Fee
Trees <6” DBH	Not regulated

<sup>1</sup> Canopy Loss Fee shall be assessed per [Section 3.2.2](#).

### 2.3.3 Special Protections for Large Trees in UR Zones

Within UR Zones, existing trees that are 24” DBH or larger shall not be removed unless preserving the tree(s) would, despite exploring reasonable site layout alternatives, significantly limit the reasonable development of the site, as follows:

- Avoiding Development in the critical root zone or drip line, or otherwise approved tree protection area, would result in a portion of a dwelling unit being less than 15 feet in width; or
- Tree removal is needed for construction or installation of necessary pedestrian access, utilities, retaining walls, or other similar improvements associated with development.

All approved tree removals 24” in DBH or greater are subject to Canopy Loss Fees per [Section 3.2](#).

## 2.3.4 Exemptions and Modifications from On-Site Tree Retention Standard

### Urban Residential (UR-1, UR-2, and UR-3) Zones

Some categories of trees (hazard, significantly damaged, fruit trees, and those damaging infrastructure) may be removed without regard to the tree retention sizes listed, and without incurring a Canopy Loss Fee, provided that sufficient documentation, such as a Certified Arborist's report, be provided to demonstrate applicability for the following categories:

1. Hazard trees. A tree shall be designated as a hazard tree by an International Society of Arboriculture (ISA) Certified Arborist who has obtained an ISA Tree Risk Assessor Course and Exam certification or Tree Risk Assessment Qualification.
2. Significantly damaged trees. A tree that has been previously topped or significantly damaged to an extent that, if left unmanaged through extensive pruning and maintenance, could become a future Hazard Tree.
3. Fruit trees.
4. Trees Damaging Existing Infrastructure. A tree that is directly damaging existing improvements such as utility infrastructure, walkways or structural foundations. A tree conflicts or interferes when it is demonstrated that there are no reasonable alternatives available to removal of the tree.

### All Other (Not Urban Residential) Zones

Tree retention outside of Urban Residential Zones, the public right-of-way, and regulated Critical Areas is not regulated. To confirm if your site is regulated as a Critical Area, refer to TMC 13.11.

## 2.4 Street Trees

Street trees are essential public infrastructure that provide multiple community benefits including improving aesthetics, calming traffic, providing habitat, shading and cooling to reduce urban heat, managing stormwater, and visual buffering and noise separation from streets. In addition to the requirements of the Zoning Code in TMC 13.06, street trees are regulated by TMC 9.20 Urban Forestry. When constructing in proximity to existing street trees, or proposing modifications such as pruning or removal of existing street trees, refer to TMC 9.20 for specific requirements.

Figure 2-7: Street Tree Requirements Overview - All Zones

District Name	Residential & Urban Residential	Commercial	X Districts	Industrial	Downtown
<b>Applicability</b>	New development; substantial alterations; new roadways; alterations to width of existing roadways; new sidewalk; and replacement of more than 50% of sidewalk along a site's frontage.			New roadways; alterations to width of existing roadways; new sidewalk; and replacement of more than 50% of sidewalk along a site's frontage. In PMI, new development & substantial alterations only apply to Marine View Drive (E. 11th Street west of Portland Avenue), Portland Avenue (south of E. 11th Street), and Port of Tacoma Road (south of E. 11th Street).	New construction; additions; substantial alterations; and replacement of more than 50% of sidewalk along a site's frontage.
<b>General Standard</b>	Four Small Trees, three Medium Trees; or two Large Trees per 100 linear feet of site frontage. When constructing new roadways or altering the width of existing roadways, the standard applies to both sides of the street.				
<b>Tree Preservation</b>	Existing street trees shall be preserved in a healthy, thriving, and safe condition per TMC 9.20, and shall not be removed unless the requirements of TMC 9.20 are met.				
<b>Landscape Plans &amp; LMPs</b>	Landscape Plan required for all street tree planting; Landscape Management Plan required for planting ≥10 street trees				
<b>Exemptions/ Flexibilities</b>				New development & substantial alterations for PMI outside of streets listed above.	

### 2.4.1 Applicability

Street trees are required in all zones throughout the City in accordance with TMC 13.06.090.B.1.e with some exceptions in the PMI district as defined below. In addition to the zone-specific tree requirements outlined in TMC, street trees are required when:

- Constructing new Permanent Roadways (see glossary for definition);
- altering the width of existing Permanent Roadways;
- constructing new sidewalk; or,
- replacing more than 50% of an existing sidewalk along a site's frontage (when 50 linear feet or more is being replaced). In the case of sidewalk replacement, street trees shall be required proportionate to the linear footage of sidewalks replaced.

## 2.4.2 Street Tree Standard

Street trees are calculated using a site's total linear frontage. For every 100 linear feet of site frontage, either four small trees, three medium trees, or two large trees are required. In other words, one small tree accounts for 25 linear feet, one medium tree accounts for 33.3 linear feet, and one large tree accounts for 50 linear feet. Small, medium, and large trees can be used in any combination, so long as the entirety of the site's frontage is accounted for.

The table below can be used to confirm that the total number of street trees proposed on-site satisfies the requirements of the site. Add the linear feet associated with each tree to determine the total linear feet planted. The total of linear feet planted must be greater than or equal to the total site frontage.

Figure 2-8: Street Tree Calculation

Required	Provided				
<b>Total Site Frontage<sup>1</sup> in linear feet</b>  <b>(LF):</b>  _____	<b>Linear Feet per Tree<sup>2</sup></b> <b>(including both existing and new trees)</b>				<b>Total Linear Feet Planted</b>
	_____ Small Trees	x	25 linear feet	=	_____ LF of small trees
	_____ Medium Trees	x	33.3 linear feet	=	_____ LF of medium trees
	_____ Large Trees	x	50 linear feet	=	_____ LF of large trees
					=

<sup>1</sup> Note that projects triggering the "new permanent roadway" requirement impact both sides of the street, and therefore require double their site frontage LF.

<sup>2</sup> Reference Appendix 7 to determine the sizes of existing and new trees.

*Example:*

*A site with 50 feet of street frontage would require a minimum of 50 total linear feet of street trees provided, which could be planted as:*

*Two Small Trees, calculated as 25LF x 2 small trees = 50 total linear feet*

*Two Medium Trees, calculated as 33.3LF x 2 medium trees = 66.6 total linear feet*

*One Large Tree, calculated as 50LF x 1 large tree = 50 total linear feet*

When required, street trees should generally be evenly spaced to create or maintain a rhythmic pattern but can be provided with variations in spacing and/or grouped to accommodate driveways, building entrances, traffic signs, or other streetscape features, or if such variations are demonstrated to better achieve the intent.

Street trees shall, when possible, be planted within the right-of-way adjacent to the curb and between the pedestrian lane/sidewalk and curb. When this is not possible or a different location would better achieve

the intent, street trees may be located elsewhere within the right-of-way, including behind the sidewalk, in street medians, parking strips or bulbouts. If neither of these preferred locations is possible, such as when existing infrastructure prevents trees from being planted within the right-of-way, trees located within 10 feet of the right-of-way may be counted as street trees. In this case, such trees only count toward the street tree requirement and do not count toward on-site Tree Canopy Credits.

When the minimum sidewalk width standards for the roadway designation and ADA compliance cannot be met with the minimum surface planting diameter, alternative pervious surface materials may be used to cover the tree pits, such as a porous, rubberized pavement, to accommodate pedestrians in the planting area.

### **2.4.3 Street Tree Retention**

Existing street trees shall be preserved in a healthy, thriving, and safe condition per the tree installation and maintenance requirements of TMC13.06.090B, TMC 9.20, and the technical specifications of this UFM. If required street trees are improperly pruned, damaged, or removed, they shall be replaced per the provisions of this section and TMC 9.20. Trees within the right-of-way that are retained consistent with TMC 13.06.090.B.3.f.(1) and TMC 9.20 count as required Street Trees according to their species as Small, Medium and Large Trees.

### **2.4.4 Exemptions and Modifications from Street Tree Standard**

#### **Downtown Districts**

In Downtown Districts, four Small Trees, three Medium Trees, or two Large Trees shall be provided per each 100 linear feet of frontage. This standard, in its entirety, shall apply to all new construction, additions, substantial alterations, and when 50 percent or more of the existing sidewalk is replaced. Street trees shall be provided, consistent with the requirements of this standard, proportionate with the linear length of existing sidewalk that is replaced. Existing street trees shall be counted toward meeting this standard. Trees should generally conform to the Tacoma Downtown Streetscape Study and Design Concepts.

#### **Port Maritime & Industrial (PMI) District**

In the PMI District, street trees are required with new development, alterations, and street improvements as specified in TMC 13.06.090.B, for development on the following gateway corridors: Marine View Drive, E. 11th Street west of Portland Avenue, Portland Avenue (south of E. 11th Street), and Port of Tacoma Road (south of E. 11th Street). In other locations within the PMI District, street trees are only required for street and sidewalk improvements as specified in [Section 2.4.1](#) above.

## **2.5 Overall Site Landscaping**

Overall site landscaping is intended to ensure that a minimum amount of landscaping is provided on a given site to enhance livability, improve community health, provide habitat, and help to soften the impacts of development.

Figure 2-9: Overall Site Landscaping Requirements Overview - All Zones

District Name	Residential & Urban Residential	Commercial	Industrial	X District
<b>Applicability</b>	New development & substantial alterations; percentage of site not covered with structures	New development & substantial alterations; percentage of site not covered with structures	Percent of parking areas over 20,000 sf	Single-purpose residential projects
<b>Landscaping percentage</b>	5%	10%	5%	15%
<b>Landscape Plans &amp; LMPs</b>	Landscape Plan required for all development; Landscape Management Plan required for developments with ≥500 square feet of landscaped area.			
<b>Exemptions/ Flexibilities</b>				Developments with structured parking are relaxed based on the percentage of structured parking to the total number of on-site parking spaces

### 2.5.1 Applicability

Site Landscaping is required in applicable zones below in accordance with TMC 13.06.090.B.4.d with some district exceptions defined below. The amount of required landscaping is determined as a minimum percentage of the site that is not covered with structures in the quantities below.

- Urban Residential Districts and Residential Districts: 5 percent
- Commercial Districts: 10 percent
- Industrial Districts: 5 percent of parking areas over 20,000 sf
- X Districts: 15 percent (for single-purpose residential projects)

### 2.5.2 Overall Site Landscaping Standard

This type of required landscaping can be provided anywhere on the site, and may be satisfied by landscaping provided to meet other requirements. When Required, Overall Site Landscaping shall consist of a mixture of trees, shrubs and groundcover plants, as follows:

- In all but Urban Residential Districts: At least one Small Tree per 200 square feet, one Medium Tree per 300 square feet, or one Large Tree per 400 square feet of required overall site landscaped area.
- In Urban Residential Districts: See tree credit requirements in TMC 13.06.090.B.3.e.
- Shrubs and groundcover shall be designed to completely cover the remaining area within 3 years.

### 2.5.3 Exemptions and Modifications from Overall Site Landscaping Standard

#### X Districts

Requirements for developments with structured parking are relaxed based on the percentage of structured parking to the total number of on-site parking spaces. For example, if all parking is structured, there is no

overall site landscaping requirement. If 50 percent of the parking is structured, then the amount of required overall site landscaping is reduced by 50 percent.

- Green roofs and roof gardens may be used to meet up to one-third of the landscaped area requirements.
- Planting strips within street rights-of-way shall not be counted toward this requirement.

## 2.6 Site Perimeter Landscaping

Site Perimeter Landscaping is intended to ensure that areas abutting property lines, not developed with structures, are attractive, and provide the environmental benefits of vegetation to enhance livability, improve community health, provide habitat, and help to soften the impacts of development.

Figure 2-10: Site Perimeter Landscaping Requirements Overview - All Zones

District Name	Residential & Urban Residential	Commercial	Industrial	X District
<b>Applicability</b>	Residential outside of UR zones	All commercial areas		
<b>General Standard</b>	Minimum 7-foot-wide site perimeter strip; 5-foot-wide site perimeter strip on sides with abutting street trees			
<b>Tree Planting Requirement</b>	At least one Small Tree per 200 sf; one Medium Tree per 300 sf; or one Large Tree per 400 sf of required landscaped area.			
<b>Landscape Plans &amp; LMPs</b>	Landscape Plan required for all development; Landscape Management Plan required for developments with ≥500 square feet of landscaped area.			
<b>Exemptions/ Flexibilities</b>	Not required for Urban Residential		Exempt	Exempt

### 2.6.1 Applicability

Site Perimeter Landscaping is required in applicable zones in accordance with TMC 13.06.090.B.4.e with some district exceptions defined below. When applicable, a Site Perimeter is required around the entire perimeter of the site. Perimeter strips may be broken for primary structures, vehicle and pedestrian access crossings, and to allow limited access to and use of utility services located in alleys, but not by accessory structures, paved areas, outdoor storage or other development.

### 2.6.2 Site Perimeter Landscaping Standard

A minimum 7-foot-wide site perimeter strip shall be provided on sides without abutting street trees. The required perimeter strip may be reduced to 5 feet for parcels of 150 feet or less in depth. A minimum 5-foot-wide site perimeter strip shall be provided on sides with abutting street trees.

The perimeter strip shall be covered with a mixture of trees, shrubs, and groundcover plants. Trees are required to be planted with at least one Small Tree per 200 sf; one Medium Tree per 300 sf; or one Large

Tree per 400 sf of required landscaped area and shall be generally evenly distributed over the site. Trees should be placed to create a canopy in desired locations without obstructing necessary view corridors.

Shrubs and groundcover shall be planted to completely cover the remaining landscape area within 3 years.

### **2.6.3 Exemptions and Modifications from Site Perimeter Landscaping Standard**

#### **Industrial, Urban Residential, and X Districts**

Site Perimeter Landscaping is not required in Industrial, Urban Residential or X Districts.

## 2.7 Parking Lot Landscaping

Parking lot landscaping is intended to provide visual relief, to enhance the aesthetic appearance, screen from adjacent sites and public areas, reduce environmental impacts of parking and other paved areas, and to provide shade and shelter for pedestrians.

Figure 2-11: Parking Lot Landscaping Tree Requirements - All Zones

Zone Name	Urban Residential	R-4	R-5	Commercial	PDB	M-1	M-2	PMI	Downtown
<b>Applicability</b>	Required for parking lots in all districts; parking lots of 16 stalls or less are exempt from parking lot interior planting requirements; parking lots of 16 stalls or less and located behind buildings that are accessed by alleys are exempt from site perimeter requirements.								All new surface parking lots, additions to parking lots, parking lots associated with buildings undergoing substantial alteration, parking lots increased in size by 50 percent, and parking lots altered on 50 percent of its surface shall provide a perimeter landscaping strip abutting adjacent sidewalks per General Landscaping and Parking Lot Perimeter requirements
<b>General Standard (overall site)</b>	One Small Tree per 700 square feet; one Medium Tree per 1,000 square feet; or, one Large Tree per 1,400 square feet of parking lot area, including drive lanes.								
<b>Parking Lot Interior Std.</b>	At least one Small Tree per 200 sf, one Medium Tree per 300 sf; or one Large Tree per 400 sf of landscaped area.								
<b>Parking Lot Distribution Standard</b>	No stall shall be more than 50 feet from a tree trunk; long rows of parking shall be broken by islands or peninsulas with trees, with no more than eight parking stalls in a row without a tree; planting areas with trees are required at all parking aisle ends; Trees required along walkways								
<b>Parking Lot Perimeter Standard</b>	Parking Lots with more than 20 stalls to provide 10-foot wide planting strip; when property is 150 feet or less in depth, perimeter strip can be reduced to 5 feet in width; At least one Small Tree per 200 sf, one Medium Tree per 300 sf; or one Large Tree per 400 sf of landscaped area.						N/A		Parking Lots with more than 20 stalls to provide 10-foot wide planting strip; when property is 150 feet or less in depth, perimeter strip can be reduced to 5 feet in width; At least one Small Tree per 200 sf, one Medium Tree per 300 sf; or one Large Tree per 400 sf of landscaped area.
<b>Landscape Plans &amp; LMPs</b>	Landscape Plan required for all development; Landscape Management Plan required for developments with ≥500 square feet of landscaped area.								
<b>Exemptions/ Flexibilities</b>	Parking lot perimeter only required between parking lots and streets							Exempt from Parking Lot Perimeter	

### 2.7.1 Applicability

Parking Lot Landscaping standards apply to all parking lots in all zones except for those identified in this section. Parking Lot Landscaping standards include:

- Parking Area Tree Minimum
- Parking Lot Interior Planting
- Parking Lot Tree Distribution
- Parking Lot Perimeter Landscaping

See Appendix 1C for Parking Lot Landscaping Calculation Worksheet.

### 2.7.2 Exemptions and Modifications from Parking Lot Landscaping Standard

#### Heavy Industrial (M-2) and Port Maritime & Industrial (PMI) Districts

Parking Lot Perimeter Landscaping is not required in M-2 or PMI Districts

#### Urban Residential (UR-1, UR-2, and UR-3) Zones

Parking Lot Perimeter Landscaping is required only between parking lots and streets in Urban Residential (UR) Districts.

#### Small Parking Lot Modification

Parking lots of 16 stalls or less are not required to meet Interior Planting requirements. Parking lots of 16 stalls or less, located behind buildings and accessed by alleys, are exempt from the Interior Planting and Site Perimeter requirements.

## 2.8 Landscaping Buffers

As defined in the Residential Transitions Standards of TMC 13.06.090.J.5 Landscaping buffers are intended to function as a substantial vegetative screen providing physical and visual separation between dissimilar districts to soften visual impacts. Landscape Buffers also provide the aesthetic and environmental benefits of vegetation including enhancing livability, improving community health, providing habitat, and helping soften the impacts of development.

### 2.8.1 Applicability

Landscaping Buffers are required in more intensive districts when abutting an R-District property, and different standards are distinguished based on the district abutting the R-District, including Industrial Zoning, all other zoning districts, and Mobile home/trailer courts abutting R-Districts.

### 2.8.2 Exemptions and Modifications from Landscaping Buffer Standard

When there is a 20-foot vertical grade difference between a development site that is located across the street or alley or is abutting a residential district property, no Landscape buffers are required along the affected property line if such grade difference is demonstrated to provide comparable protection.

Wherever a development site is separated from a residential district by an arterial street, highway, or alley, providing a Landscape buffer is not required.

The Director may waive the requirement for a screening if equivalent screening is provided by existing parks, parkways, recreation areas, or by topography or other natural conditions.

The Director may waive the requirement for a screening if the R-District property being screened is in long-term use for a purpose other than residential, and which would not be negatively impacted by adjacency to a more intensive use.

The continuous landscaping buffer may be interrupted to the minimum extent necessary to accommodate walkway access and preferred driveway access to and from the property and to allow limited access to and use of necessary utilities.

A buffer is not required between the front of a residential building and the street.

Single-, two-, three-family and townhouse developments are exempt from all landscaping buffer requirements.

## **2.9 X District Front Yard and Foundation Landscaping**

In high pedestrian traffic areas, trees, shrubs and groundcover plantings can be used to soften the visual appearance of exposed foundations and building frontages.

### **2.9.1 Applicability**

Within X District Zones, in areas where buildings are not located adjacent to the sidewalk, the area between the public sidewalk and buildings shall incorporate expanded sidewalk space, outdoor seating, plazas and/or landscaping with a combination of trees, shrubs, and/or ground cover plants.

All street-facing elevations must have landscaping along any exposed foundation. The landscaped area may be along the outer edge of a porch instead of the foundation. This landscaping requirement does not apply to portions of the building façade that provide access for pedestrians or vehicles to the building.

### **2.9.2 Exemptions from X District Front Yard and Foundation Landscaping Standard**

This standard does not apply to zones outside of X Districts.

## Chapter 3 Incentives, Flexibility, and Fees

Use this chapter to determine when incentives and flexibility offered may apply to your project. Retaining trees and tree groves, planting evergreen species, and using low impact development techniques provide opportunities to reduce required landscaping and/or offer flexibility in building standards. If required trees do not fit on-site with these techniques, flexibility is offered to plant trees offsite through “Tree Banks” or by paying a Tree Canopy Credit Fee to support City tree planting elsewhere. In some instances when larger trees are removed, Canopy Loss Fees may be assessed, which also helps fund tree planting and maintenance throughout the City.

### 3.1 Incentives and Flexibility

#### 3.1.1 Retaining Trees for Credit Using “Tree Quantity” System

In zones with tree requirements that do not use a Tree Canopy Credit system, or when trees are required to meet specific quantity standards, such as with Site Perimeter Landscaping, retained trees shall count according to their species as Small, Medium and Large Trees in the following amounts:

- One required tree for every retained tree of at least equal size;
- Two required trees for every retained tree that is 8 inches to 20 inches in DBH;
- Three required trees, for every retained tree 20 inches to 32 inches in DBH;
- Four required trees, for every retained tree over 32 inches in DBH.
- In order to facilitate and provide an incentive for the retention of substantial numbers of mature trees, additional flexibility is available on Parking Lot Distribution requirements.

#### 3.1.2 Flexibility for Extra Street Trees (UR Zones)

Street trees do not count toward on-site Tree canopy credits, except those planted above the required amount, per TMC 13.06.090.B.3.g.(5).

In some instances within UR Zones, street trees provided that are above the requirements may be applied to onsite tree planting requirements. To determine whether planted trees exceed street tree requirements and are eligible for onsite tree canopy credits, use the table below. Subtract the total linear feet of all trees provided from the total required linear feet. Linear feet above the requirement can be translated to tree canopy credits using the values in Figure 3-2.

Figure 3-1: Calculating Linear Feet above Requirements

Required	Provided (from worksheet above)	Additional (Required – Provided)
Total Site Frontage in linear feet (LF): _____	_____ LF of all trees	_____ LF provided above the requirement

Then use the table below to calculate Tree Canopy Credits from extra street trees that can count toward required onsite Tree Canopy Credits.

Figure 3-2: Linear Feet and Tree Canopy Credit Equivalent

Linear Feet Above the Requirement	Tree Equivalent	Eligible Tree Canopy Credits
0-25 LF	Does not satisfy requirement for additional Tree Canopy Credit	Not eligible
25 – 32 LF	Small Tree	200 credits
33 – 49 LF	Medium Tree	500 credits
50 LF	Large Tree	1,000 credits

Reference Tacoma standard plans LS-01, LS-02, and LS-03 for required Street Tree planting details.

### 3.1.3 Flexibility for Retained Tree Groves

A tree grove is comprised of 8 or more existing trees, of 12” DBH or greater, that form a continuous canopy. It excludes trees listed in the Prohibited and Not Recommended tree list in Appendix 7D of this UFM. Additional flexibility is available per TMC 13.06.020.F.3 for retention of a tree grove, which includes retention of trees and/or understory vegetation that cannot be removed without damaging the health of the grove.

### 3.1.4 Evergreen Trees

Scientific research shows that evergreen trees provide more consistent stormwater benefit to the urban environment than deciduous trees, due in part to their persistent foliage year-round. Therefore, planting evergreens may be preferred over deciduous trees in appropriate situations. A credit is offered to incentivize evergreens above and beyond the minimum requirements for evergreens (refer to [Section 4.2.2 Tree Selection and Species Diversity](#) of this Manual) to reflect this benefit.

New evergreen trees, above and beyond those otherwise required, shall receive an additional 10% Tree Canopy Credit (a scale factor of 1.1).

*Example:*

*A site with 2 Medium evergreen trees beyond the required number of evergreen trees would be calculated as: 500 credits x 2 trees x 1.1 = 1,100 Tree Canopy Credits.*

If greater than two-thirds of required trees are evergreens, additional flexibility is available on Parking Lot Distribution requirements per TMC 13.06.090.B.4.g.(6).

### **3.1.5 Low Impact Development Techniques**

Low Impact Development Best Management Practices (LID BMPs) that meet both stormwater management and tree requirements, like tree retention (BMP L615) and permeable pavement over planting soil (BMP L633 with suspended pavement systems), are encouraged. Vegetated LID BMPs may be used to meet all or a portion of the landscaping requirements. For sites utilizing LID BMPs as defined in the City of Tacoma Stormwater Management Manual as their primary stormwater management approach, additional flexibility is available on Parking Lot Distribution requirements per TMC 13.06.090.B.4.g.(6).

### **3.1.6 Tree Banks (UR Zones)**

Required trees to satisfy On-Site Tree Canopy Credit requirements in UR Zones may also be planted on a separate property, such as a religious organization, or public property, such as a park or school, as long as it is within the same Watershed as the project and necessary agreements are in place to ensure the long-term maintenance and protection of the tree(s). To use this option, the project proponent is responsible for identifying the alternative location and securing a qualifying agreement that conforms to City requirements from the owner of the receiving property transferring the responsibility for the required tree(s). Additional inspections and monitoring may be required to ensure the trees become established and provide the required long-term benefits. Off-site Tree Banks shall not be double counted towards the requirements of the property on which they are planted.

### **3.1.7 Flexibility for Ownership Opportunities and Accessory Dwelling Units (UR Zones)**

Flexibility to certain development standards is provided in Urban Residential Zones to encourage developments that create new homeownership opportunities to owner-occupant households earning no more than 150 percent of the Pierce County family median income for at least the first 5-years from certification of occupancy. To ensure compliance, a binding title restriction conforming to City requirements shall be recorded on the property to use this incentive.

For current owner-occupant households earning no more than 150 percent of the Pierce County family median income, flexibility is provided to encourage the development of Accessory Dwelling Units (ADUs). For these instances, incentives would be available for those adding up to two ADUs on their property and adding a binding title restriction that one of the units will be owner-occupied for at least the first 5-years from certification of occupancy.

Included in these incentives is a reduction in on-site Tree Canopy Credit requirements for UR Zones to the minimum “floor” level of 10% without the need for Tree Canopy Credit Fees or Canopy Loss Fees.

### **3.1.8 Flexible Development Standards When Retaining Trees (UR Zones)**

Developments retaining single trees or tree groves are granted flexibility on development standards in the form of increased building height, reduced building setbacks from property lines, and reductions in required parking ratios. See TMC 13.06.0202.F.3 for more information.

### 3.1.9 Prioritization of Tree Retention and Tree Canopy over Parking

If complying with both tree requirements and on-site vehicular parking requirements would result in it being infeasible to achieve the maximum FAR permitted in the zone, there is flexibility to reduce or waive parking requirements in order to meet Tree Canopy Credit and tree retention requirements, per TMC 13.06.090.B.3.g.(8), and as required by RCW 36.70A. To receive an exemption or reduction from residential off-street vehicle parking requirements, an applicant must demonstrate that without an exemption at least one of the following would be necessary:

- Removal of trees exceeding 6-inches DBH to create space for vehicle driveways, parking, or
- Non-compliant pedestrian access, despite exploring reasonable site layout alternatives;
- Removal of trees in the public right-of-way for driveway construction; or,
- Purchase of off-site tree canopy credits to meet tree canopy requirements.

## 3.2 Fees

### 3.2.1 Applicability

Canopy Loss Fees will be assessed when applicable in Urban Residential Zones. In-Lieu Fees will be assessed when 1) Tree Canopy Credit requirements are not met in zones that utilize Tree Canopy Credits or 2) Tree Planting requirements are not met for standards (or in zones) that do not utilize a Tree Canopy Credit system.

### 3.2.2 Canopy Loss Fee – Urban Residential Zones 1, 2, and 3

A canopy loss fee will be assessed in Urban Residential Zones for removal of trees 6” DBH or larger, unless exempt under TMC 13.06.090.B.3.e.(3)(c). The Canopy Loss Fee will be placed into an account established by the City to support the Urban Forestry Program in planting, maintenance, and replacement of trees on public property or the right-of-way. The City will utilize those fees to plant and maintain trees in the same Watershed as the project that generated those fees.

#### Canopy Loss Fees for Tree Removal 18” DBH or larger

For trees 18” DBH or larger, the Canopy Loss Fee is determined by a cost-per-inch of DBH removed:

Figure 3-3: Canopy Loss Fees for Removal of Trees 18” DBH or Larger

Inches of Trees Removed	Inches of Trees Planted	Canopy Loss (inches)	\$ per Inch	Canopy Loss Fee
_____	- _____	= _____	x \$130 per inch DBH	= _____

**Canopy Loss Fees for Tree Removal 6” to 18” DBH**

For trees between 6” and 18” DBH, the Canopy Loss Fee does not apply to trees removed that are above and beyond the site’s applicable Tree Canopy Credit requirement. However, for trees removed below the applicable Tree Canopy Credit requirement, a Canopy Loss Fee shall be assessed and is determined by a cost-per-inch DBH removed minus the total caliper inches of replacement trees planted:

Figure 3-4: Canopy Loss Fee for Removal of Trees 6” to 18” DBH

Inches of Trees Removed below required minimum	Inches of Trees Planted	Canopy Loss (inches)	\$ per Inch	Canopy Loss Fee
_____	- _____	= _____	x \$130 per inch DBH	= _____

Example:

*On a 6,000 square foot lot in a UR-1 zone with a 30% Tree Canopy Credit requirement, the required Tree Canopy Credits are 1,800. If the UR-1 development site currently has an equivalent of 2,400 Tree Canopy Credits from existing trees on site, an 8” DBH tree would be eligible for removal without being assessed Canopy Loss Fees, as an existing 8” DBH tree is worth 75 credits per inch (per [Section 2.2.4](#) of this UFM).*

*[6,000 SF lot] x [30% Tree Canopy Credit requirement for UR-1] = 1,800 required Tree Canopy Credits*

*[2,400 existing Tree Canopy Credits] – [1,800 required Tree Canopy Credits] = 600 Tree Canopy Credits above requirement*

*[8” DBH tree] x [75 credits per inch] = 600 credits, and is eligible for removal without Fee*

**3.2.3 Tree Canopy Credit (In-Lieu) Fee**

**Tree Canopy Credit Fee In-Lieu of Required “Tree Canopy Credits”**

As an alternative to planting or retaining trees on the site to meet applicable Tree Canopy Credit requirements for zones that require tree canopy credits, in-lieu funds may instead be placed into an account established by the City to support the Urban Forestry Program in planting, maintenance, and replacement of trees on public property or the right-of-way. The required amount will be assessed per Tree Canopy Credit as specified, and equal to 1.5 times the cost to purchase and plant the required landscaping and maintain it through establishment.

Tree Canopy Credit Fees can be utilized for all but 10% of a lot’s area in all UR zones. In other words, at least 10% of the lot's area must meet Tree Canopy Credit requirements on site, even if the Tree Canopy Credit Fee is utilized. The City will utilize these fees to plant and maintain trees in the same Watershed as the project that generated the fees.

Figure 3-5: Current Tree Canopy Credit Fee is \$15 per Tree Canopy Credit

Required Tree Canopy Credits per <a href="#">Section 2.2</a>	Provided Tree Canopy Credits (10% min)	Credit Deficit	\$ per Tree Canopy Credit	Tree Canopy Credit Fee
_____	- _____	= _____	x \$15 per Credit	= _____

*Example:*

*6,000 sf lot would still be required to meet Tree Canopy Credits for 10% of its lot area, or 600 credits. This could be met by retaining (1) 8” DBH tree. It could also be met by planting (3) small trees, (2) medium trees, or (1) large tree.*

**Fee In-Lieu of Required Tree Planting (Non-Tree Canopy Credit Standards)**

In limited instances when specific site characteristics do not support the preservation or planting of trees for landscaping standards or in zones with tree requirements that do not use a Tree Canopy Credit system, in-lieu of tree planting funds may instead be paid into the City Urban Forestry Fund.

To utilize these in-lieu fees, applicants must demonstrate to the satisfaction of the Director that specific site characteristics make the installation of landscaping on the site problematic to its reasonable use. Landscaping must still be installed to the maximum extent practicable. Landscaping buffer requirements may not be modified through this provision. Funds collected will be used by the City Urban Forestry Program to plant trees on other public or private property within the City. The required amount will be equal to 1.5 times the cost to purchase and plant the required landscaping and maintain it through establishment, or \$3,000 per tree.

## Chapter 4 General Planting Standards

This chapter describes plant material minimum standards that apply to landscaping both on private property (on-site) and within the public right-of-way (off-site). The following standards shall apply to all vegetation used to satisfy landscaping requirements of the Tacoma Municipal Code.

### 4.1 Plant Quality and Condition

Plants shall meet the standards of the most current edition of American Standard for Nursery Stock (ANSI Z60.1) and as further specified in this Manual. Where ANSI Z60.1 Standards and this Manual conflict, this Manual shall prevail. Plant material should be obtained from established commercial licensed nursery growers and installed by qualified landscape professionals.

To increase plant survivability, all plant material should be:

- balled and burlapped (B&B), containerized, bare root and/or grown in root control bags;
- well-watered prior to shipping and checked for adequate moisture at arrival;
- maintained under shade and irrigated regularly if not planted within 24 hours of delivery. B&B or bare-root plant material must be healed-in while being stored prior to planting;
- planted immediately once removed from the packaging, such as the container, burlap or root control bag; and,
- protected from extreme temperatures, wind and theft, during transport and storage on-site.

It is intended that all plants installed in the required landscaped areas will reach their full mature size. Pruning that adversely affects the healthy living condition of the plant, significantly damages the natural growing form of the plant, eliminates or significantly reduces the plant function (i.e. canopy, stormwater absorption/benefit) will be considered removal, and is subject to provisions in TMC 13.06.090B and 13.05.150 enforcement including, but not limited to, fines and required plant replacement.

#### 4.1.1 Climate Adapted and Native Plant Requirements

All required plants to meet landscaping standards regulated under the TMC shall be climate-adapted. The retention and use of natives is encouraged and permitted for all landscaping. Invasive species, as identified in the UFM including Appendix 7D, shall not count toward meeting required plantings. Noxious weeds and weeds listed as Class A, B, or C as determined by the Pierce County Noxious Weed Control Board, are prohibited from being planted in required landscaped areas.

#### UR Zones

In UR-1 and UR-2 zones, 50 percent of all plants that are not trees must be native to western Washington and/or western Oregon.

## Open Space Corridors and Fish and Wildlife Habitat Conservation Areas

100 percent of plants (excluding trees) required for landscaping located within Comprehensive Plan designated Open Space Corridors, and a minimum of 75 percent in adjacent areas within 50 feet of Open Space Corridors, must be native to western Washington and/or western Oregon. A minimum of 50 percent of required landscaping located within 50 feet of designated Fish and Wildlife Habitat Conservation Areas must be native to western Washington and/or western Oregon.

## 4.2 Trees

In accordance with City of Tacoma policies to establish a healthy and diverse urban forest, as defined in the Urban Forest Management Plan adopted in 2019, the following standards apply to all trees required by TMC 13.06.090B.

### 4.2.1 Tree Sizes

Trees are categorized as Small, Medium or Large based on the potential long-term canopy benefits of their species. Size is determined by Canopy Factor, which is calculated using the following formula:

$(\text{mature height in feet}) \times (\text{mature crown spread in feet}) \times (\text{growth rate number}) \times 0.01 = \text{Canopy Factor}$ .

The growth rate number is 1 for slow growing trees, 2 for moderately growing trees, and 3 for fast growing trees.

(A) Large Trees = Canopy Factor greater than 70

(B) Medium Trees = Canopy Factor from 40 to 70

(C) Small Trees = Canopy Factor less than 40

Reference Appendix 7 for pre-approved lists of Large, Medium, and Small Trees.

### 4.2.2 Tree Selection and Species Diversity

Diversification of plant species lessens the impact and likelihood of disease and pest infestation, and provides diverse habitat to better meet the needs of wildlife within a healthy urban forest. To ensure tree species diversity, the following standards shall apply.

For projects involving the planting of:

- 4 to 10 trees, a minimum of 2 different genera shall be used.
- 11 to 25 trees, a minimum of 3 different genera and a mixture of tree types (evergreen and deciduous) shall be used.
- greater than 25 trees, one genera shall not exceed 25 percent and a minimum of 20 percent of the total number of trees shall be evergreen.

### Fruit producing (edible) trees

Edible fruit producing trees may be planted to satisfy tree planting requirements on-site, including in on-site parking areas/lots, as well as the public right-of-way. Be advised that some fruit tree pruning practices might be considered “excessive pruning” under TMC 13.06.090B, and not permitted under TMC 9.20.220, and as such, pruning that adversely affects the healthy living condition of the plant, significantly damages the natural growing form of the plant, eliminates or significantly reduces the plant function (i.e. canopy, stormwater absorption/benefit) will be considered removal, and is subject to enforcement provisions in TMC 13.06.090B, 13.05.150, and 9.20 including, but not limited to, fines and required plant replacement.

### 4.2.3 Tree Quality and Condition

At the time of planting all trees shall:

- Have natural shape (no sheared or semi-sheared trees);
- Have a single, strong, central leader;
- Have branches evenly spaced around the central leader, except for trees with ascending branches (ex. *Ulmus americana* and *Zelkova serrata*); and,
- For trees that have been pruned – only proper pruning cuts (not flush cuts), pruned to the outside of the branch collar, are permitted.

Deciduous Trees shall meet the following requirements:

- At least 50% of the deciduous trees provided shall be a minimum of 2-inch caliper at the time of planting. The remaining deciduous trees shall be a minimum of 1½-inch caliper at the time of planting.
- Street trees with ascending branches (ex. *Ulmus americana* and *Zelkova serrata*) shall have a trunk free of branches to a minimum of three feet, measured from the ground elevation.
- All other deciduous street trees shall have a trunk free of branches to a minimum of five feet in height, measured from the ground elevation.
- All deciduous trees shall be species with the ability to develop a minimum branching width of six feet within five years. Weeping or excessively fastigate or columnar species (e.g. weeping cedar) that do not meet this standard are not eligible to satisfy a tree planting requirement of the TMC.

Evergreen Trees shall meet the following requirements:

- At least 50% of the evergreen trees provided shall be a minimum of six feet tall and shall have a trunk free of branches up to two feet in height, measured from finish grade. The remaining evergreen trees shall be a minimum of five feet tall at the time of planting.
- All evergreen trees shall be species with the ability to develop a minimum branching width of six feet within five years. Weeping or excessively fastigate or columnar species (e.g. weeping cedar) that do not meet this standard are not eligible to satisfy a tree planting requirement of the TMC.

#### **4.2.4 Tree Placement in the Right-of-Way**

While the preferred placement of street trees is in the amenity zone (between the back of curb and the pedestrian walkway), often there are other suitable locations to place street trees. Medians, bulb-outs and converted parking spaces offer additional opportunities for street tree placement. If placement of street trees in the amenity zone is not desired due to potential conflicts with signage, buildings, or other infrastructure, alternative placement locations such as those described above may be accepted provided that a minimum of 5'-0" free and clear walkway is maintained. In the case of narrow or vaulted walks which provide less than the required soil volume, alternate locations and/or in-lieu fees are the preferred approach to meeting the street tree requirements, contact PDS for approval requirements.

Trees planted in pots do not count towards street tree requirements, as defined in TMC 13.06.090B, due to the impeded ability of the tree to reach its full intended size and function. Trees planted in raised planting beds with open soil access at the bottom of the raised bed (i.e. "open bottom" planters) may count towards the Street Tree requirement only if it can be demonstrated that the raised bed meets the required minimum soil depth and unpaved planting area requirements contained in [Section 4.2.6](#) of the UFM.

Permission from the City's Public Works Traffic Engineering for alternative placement of street trees in the Right-of-Way (ROW) is required. The graphics below illustrate various alternative placement options.

Figure 4-1: Tree Placement in Bulb-Outs

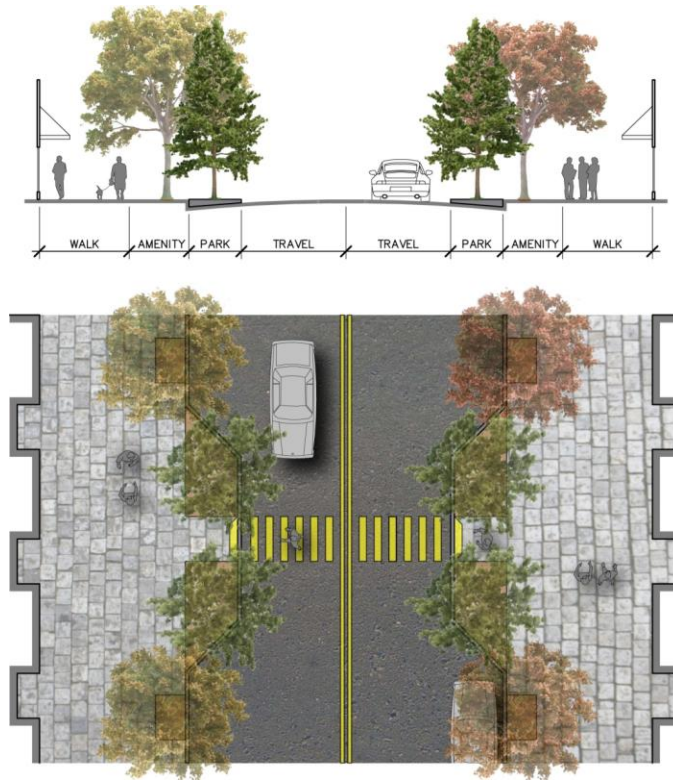
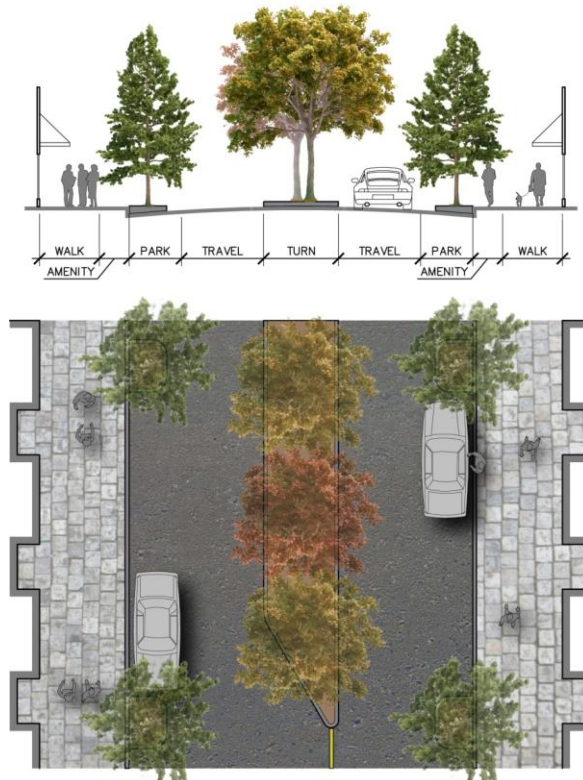

Figure 4-2: Tree Placement in Medians and Converted Parking Spaces



#### 4.2.5 Tree Placement under Overhead Utilities

To avoid conflicts with overhead utilities, trees planted under overhead utility lines must be tree species that have a maximum mature height (at 25 years of age) not greater than 25 feet. For preapproved trees which meet this criteria, refer to Appendix 7, Approved Tree List.

The graphic below illustrates the clearance constraints of a tree planted under overhead utilities, adjacent to a sidewalk (required vertical feet minimum clearance) and a roadway (required 14 vertical feet minimum clearance). There is a reduced quantity of tree species that are able to meet these growing conditions, and careful consideration for tree selection is advised.

Figure 4-3: Tree Placement Under Overhead Utilities

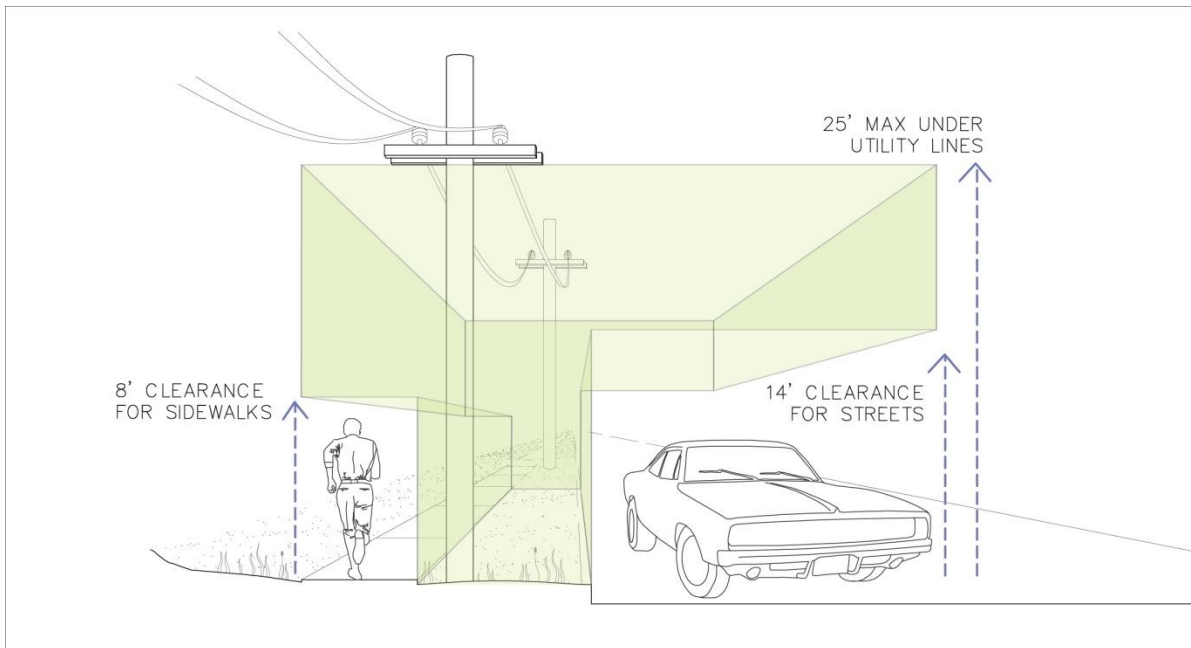

#### 4.2.6 Soil Depth and Unpaved Planting Area

A minimum 3 foot depth of amended existing native soil or new topsoil non-mechanically compacted to account for settling shall be provided for all newly transplanted trees, except when the tree is planted within the drip line of existing mature trees. In the case of street trees, the finished soil level including mulch (finished grade) shall be flush with the adjacent pavement surface or curb. Refer to Standard Plan LS-01 Street Tree Planting Detail.

Minimum tree trunk setbacks, surface planting diameter, soil volumes and spacing requirements shall be provided for healthy tree growth, as follows:

Figure 4-4: Soil Standards

Per Tree Minimum	Small Trees	Medium Trees	Large Trees
<b>Unpaved planting area, assuming 3 ft soil depth (sq. ft.):</b>	167	334	400
<b>Soil volume (cu. ft.)<sup>1</sup></b>	500	1,000	1,200
<b>Soil volume per tree, if soil is shared by multiple trees (cu. ft.)</b>	500	800	1,000
<b>Unpaved surface planting diameter (ft.)<sup>2</sup>:</b>	5	6	7

<sup>1</sup> Minimum soil volume shall be achieved with soil depths of 3 feet where possible, but in no case shall be less than 24 inches. Soil depth provided to meet this cubic foot minimum can increase to 4' depths only where a soil depth of 3' would not allow Tree Canopy Credits to be met on-site.

<sup>2</sup> This is the minimum unpaved dimension of planting area in any direction, often referred to as a “tree pit opening”. Provided that suspended pavement systems are used to meet required soil volume underground, this diameter can be reduced to 4' if compliance with ADA accessible sidewalk width standards is otherwise infeasible.

Exceptions to these minimums may be approved by the Director of Planning and Development Services, if a certified arborist confirms that healthy tree growth will be achieved, and infrastructure and other conflicts will be avoided.

Figure 4-5: Multiple Ways to Achieve Required Soil Volume

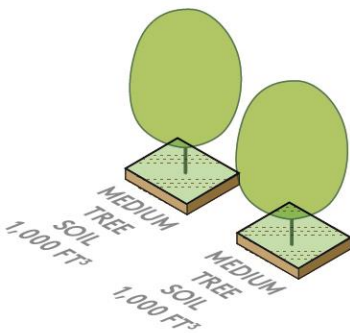

Each tree needs a minimum amount of soil to survive into maturity.

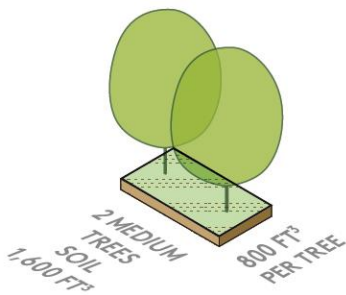

But shared soil volumes allow a lower volume to be used per tree.

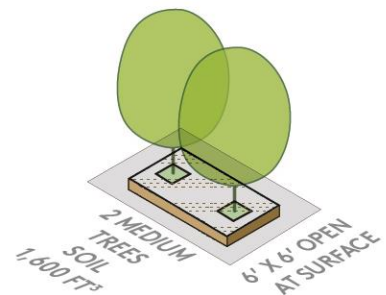

And with suspended pavement systems, paving can extend over soil, provided the minimum opening is maintained at the surface.

For specific requirements regarding paving around existing trees, refer to [Chapter 7 Tree Protection During Construction](#).

Approved options for the treatment of unpaved planting areas include:

- Planting: groundcovers, perennials and shrubs with mulch covering exposed soil area. Plants (other than trees) must be less than 3 feet in mature height if planted in the public right-of-way.
- Mulch: organic wood chip mulch and/or permeable inorganic mulch. Finished grade after mulch application shall be a minimum of 1” below the adjacent pavement surface or curb.

Figure 4-6: Treatment of Unpaved Planting Areas

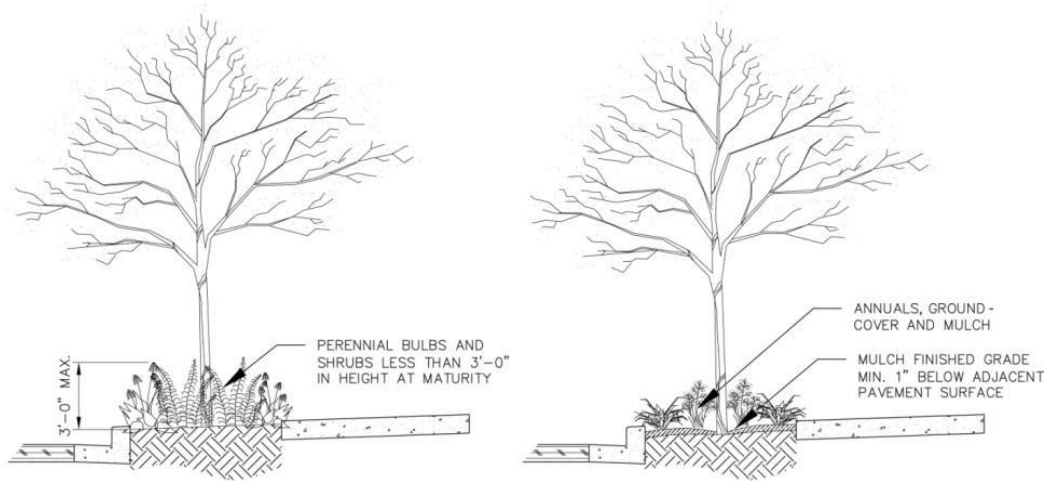

#### 4.2.7 Tree Spacing Standards

It is recommended that all required trees are planted according to the minimum spacing standards listed below to achieve their full benefits. The distance between trees is measured from stem to stem, referred to as “on-center” (OC). The distance between trees and structures shall be from stem to structure wall.

Figure 4-7: Minimum Spacing Standards for Trees (OC)

	Small Trees *	Medium Trees *	Large Trees *
<b>Minimum spacing from primary structures and other trees, in feet:</b>	10	16	22

\* as defined in glossary under “Tree Sizes”

NOTE: TMC13.06.090B states that the minimum spacing requirements for small, medium and large trees is 10 feet, 16 feet and 22 feet respectively. These minimum tree spacing requirements may be reduced, with approval from the City, if it can be demonstrated that the reduced spacing will not have any negative impacts on the health of the trees.

For tree spacing and minimum unpaved area standard plans, refer to Standard Plan No. LS-03 Tree Well Dimension.

#### 4.2.8 Tree Setback Standards

The following are minimum tree setback and clearance standards to avoid infrastructure conflicts:

Figure 4-8: Minimum Tree Setbacks

From – To	Setback Distance (in feet)
<b>Center Line of Tree to Center Line of:</b>	
Street Corner (extension of outside face of curb)	25
Stop or Yield Signs	25
Utility Poles	15
Other Traffic Control Signs	5
<b>Center Line of Tree to Edge of:</b>	
Driveways	5
Face of Curb	2.5
Pavement	2
<b>Edge of Tree to Edge of:</b>	
Utility Worker Access Lids	5
Gas Shutoff Valves	5
Fire Hydrants and Hydrant Branches	10
Water Meter, Water Service and Water Mains	5
Storm Inlets, Catch Basins and Manholes	5
Storm/Sanitary Service Connections and Mains	5

Figure 4-9: Minimum Tree Clearances (at Maturity)

Lowest Branch to Surface of:	Branch Clearance (feet)
<b>Streets</b>	14
<b>Sidewalks</b>	8

## 4.3 Shrubs

Existing shrubs, which comply with the minimum plant sizes below, may count toward the required plantings. Invasive and Noxious Weeds (Class A, B or C) as defined by the Pierce County Noxious Weed Control Board are not permitted to be planted in the landscaped areas. Fruit producing shrubs may be planted in all landscaped areas, provided they meet all other applicable requirements for sizing and diversity.

Except in cases where required landscaping is intended to provide dense visual buffers or to enhance natural conditions, trees and shrubs planted within or directly adjacent to the right-of-way (within 15 feet of sidewalk/curb edge) and other publicly accessible areas shall be selected and maintained to maximize visibility at eye level for safety. To meet this requirement, shrubs shall be chosen that will grow to a mature height under 3 feet. Tree species shall be selected and pruned (once tall enough) to maximize views below 7 feet in height.

For shrub transplanting standards, refer to Standard Plan LS-05 Shrub Planting.

### 4.3.1 Shrub Diversity

When planting shrubs to satisfy landscaping requirements the following standards must be applied:

- If more than 25 shrubs are required, no more than 20 percent may be of one species.

### 4.3.2 Shrub Stock

- All shrubs provided shall be a minimum 1-gallon container size at the time of planting, or 18-inches in height if bare root stock is used.

## 4.4 Groundcover

Turf forming grasses and mulch are not considered groundcover. Invasive and Noxious Weeds (Class A, B, or C) as defined by the Pierce County Noxious Weed Control Board are not permitted to be planted in the landscaped areas. Fruit producing groundcovers may be planted in all landscaped areas, provided that they meet all other applicable requirements for sizing and diversity.

For groundcover transplanting standards, refer to Standard Plan LS-06 Groundcover Planting.

### 4.4.1 Groundcover Stock

- Groundcover plants provided shall be at least a 4-inch pot size, 10-inch plugs/cones or 6-inches in height if bare root stock is used at the time of planting.

#### 4.4.2 Groundcover Spacing

Groundcover plants are required to be planted in the remainder of the landscaped area, not otherwise covered by trees and shrubs, so they fill the area within the first three years of planting. The recommended spacing between individual groundcover plants is commonly described on the label accompanying plant material and/or from published horticultural sources. Groundcover width at maturity can also be used to determine groundcover plant spacing.

The following steps can be used to calculate the quantity of groundcover plants needed to fill a given area using a standard triangular spacing pattern:

**Step 1)** Convert the area of planting space from square feet to square inches (multiply sq. ft. by 144)

**Step 2)** Calculate the space occupied (sq. in.) per plant =

$X$  = mature width or recommended plant spacing

$Y$  = spacing between plant rows, (which is equal to  $X (0.866)$ )

$X*Y$  = space occupied in square inches per plant

The table below illustrates this process for typical plant spacing (mature width) of groundcover plants.

Figure 4-10: Groundcover Spacing Standards

Spacing in inches between plants (mature width) = $X$		Spacing in inches between rows of plants = $Y$ or $0.866X$			Space occupied in square inches per plant = $X(Y)$	
$X=$	6	$Y =$	$6(0.866)$	$=5.196$	$6(5.196)$	$=31.176$
$X=$	8	$Y =$	$8(0.866)$	$=6.928$	$8(6.928)$	$=55.424$
$X=$	10	$Y =$	$10(0.866)$	$=8.66$	$10(8.66)$	$=86.6$
$X=$	12	$Y =$	$12(0.866)$	$=10.392$	$12(10.392)$	$=124.704$
$X=$	18	$Y =$	$18(0.866)$	$=15.588$	$18(15.588)$	$=280.584$
$X=$	24	$Y =$	$24(0.866)$	$=20.784$	$24(20.784)$	$=498.816$
$X=$	30	$Y =$	$30(0.866)$	$=25.98$	$30(25.98)$	$=779.4$
$X=$	36	$Y =$	$36(0.866)$	$=31.176$	$36(31.176)$	$=1122.336$
$X=$	48	$Y =$	$48(0.866)$	$=41.586$	$48(41.586)$	$=1996.128$

**Step 3)** Calculate the total number of plants needed for the planting area.

$$\frac{\text{total planting area in square inches}}{\text{space occupied per plant}} = \text{total number of plants}$$

The following table provides examples of the plant quantities needed to fill 100 square feet of planting space.

Figure 4-11: Plant Quantities per 100 sq ft

If the recommended spacing (mature width) is:	Plants required to fill 100 square feet of area:
<b>6 inches</b>	460
<b>8 inches</b>	260
<b>10 inches</b>	167
<b>1 foot</b>	115
<b>1.5 feet</b>	51
<b>2 feet</b>	29
<b>2.5 feet</b>	19
<b>3 feet</b>	13
<b>4 feet</b>	7

An illustrated example of the triangular spacing pattern for groundcover spaced apart at 12” on center in a planting area that is 15 square feet is shown below.

Figure 4-12: Groundcover Planting Spacing Example

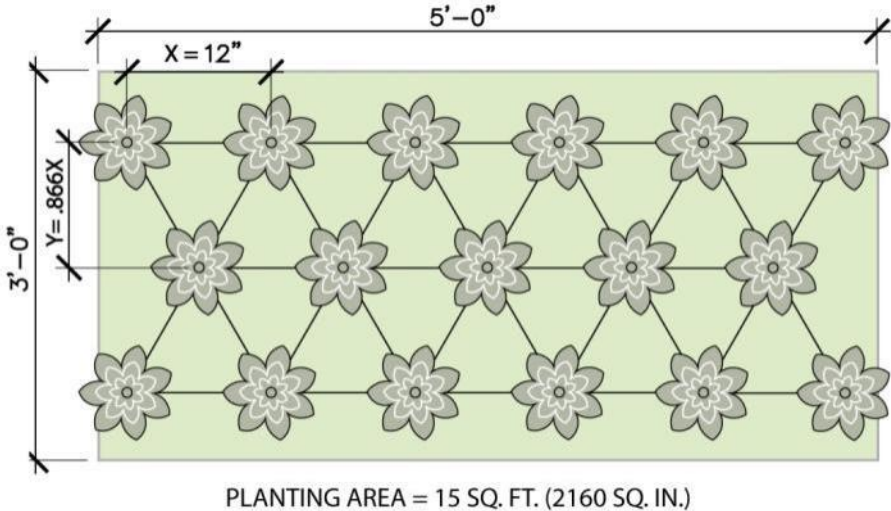

## Chapter 5 Landscape Plans

When required by TMC 13.06.090B, Landscape Plans shall be prepared by a Registered Landscape Architect, Certified Landscape Technician, Certified Arborist, or Certified Professional Horticulturalist. Developments with less than 500 square feet of landscaped area may submit a Landscape Plan prepared by someone other than these listed professionals.

Landscape Plans must be drawn to scale and show all of the following:

- Plant species names (common and scientific);
- Plant stock sizes, condition, and quantity;
- Installation location of plant materials;
- Existing and proposed utilities, underground and overhead;
- Existing and proposed bus stops (as applicable);
- Existing trees planned to be retained, including their tree protection zones;
- Finished grade; and,
- Required irrigation systems; if irrigation options 1 and/or 2 are selected per Chapter 6 of this Manual.

For an approved Sample Landscape Plan, see Appendix 2 of this Manual.

## Chapter 6 Landscape Management Plans (LMPs)

Landscape Management Plans (LMPs) shall be submitted for all development proposals with landscape requirements including greater than 500 square feet of required landscape area or planting of 10 trees or more. Projects with less than 500 square feet of required landscaping and fewer than 10 trees are not required to submit a LMP. LMPs may be incorporated into another maintenance plan, such as an overall site maintenance plan, if applicable. When required, Landscape Management Plans shall be prepared by a Registered Landscape Architect, Certified Landscape Technician, Certified Arborist, or Certified Professional Horticulturalist, unless otherwise approved by the City, and shall be submitted in a form specified by the City.

Landscape Management Plans shall address the following:

- Entity responsible for maintenance of the landscape during the establishment period (3 years following planting);
- A schedule of maintenance activities, including, but not limited to, pruning, watering, fertilization, control of Noxious Weeds and Nuisance Plants and replacement of dead and/or damaged plant materials;
- Irrigation option(s) selection and maintenance schedule; and,
- Inventory of trees to be filled out upon project completion and updated during the establishment period.

NOTE: It is intended that all plants installed in the required landscaped areas will reach their full mature size. Pruning that adversely affects the healthy living condition of the plant, significantly damages the natural growing form of the plant, eliminates or significantly reduces the plant function will be considered removal, and is subject to enforcement provisions in TMC 13.06.090B, 13.05.150, and TMC 9.20, including, but not limited to, fines and plant replacement.

Refer to Appendix 3 for an approved Sample Landscape Management Plan template.

Note: Per the City of Tacoma Stormwater Management Manual, facilities that manage stormwater are required to have Operations and Maintenance (O&M) Manuals. This information does not need to be recreated as part of the LMP, but rather should be reference the O&M Manual for the facility and where the O&M Manual can be found.

## 6.1 Irrigation Option(s) Selection and Maintenance Schedule

One or more of the irrigation options listed below must be selected for all required landscaping, per TMC 13.06.090B. If more than one irrigation option is selected, the required Landscape Plan must clearly demarcate where landscaping is to be irrigated and which irrigation option is proposed for each area.

- Option 1: A permanent built-in irrigation system with automatic controller designed to provide sufficient water to ensure that all required landscaping survives through the establishment period. The system design shall be prepared by a Registered Landscape Architect, Certified Landscape Technician, Certified Professional Horticulturalist, or irrigation specialist.
- Option 2: A temporary irrigation system with automatic controller designed to provide sufficient water to ensure that all required landscaping survives through the establishment period. After the establishment period, temporary irrigation systems may be abandoned or removed if removal will not damage the established plants. The irrigation system design shall be prepared by a Registered Landscape Architect, Certified Landscape Technician, Certified Professional Horticulturalist, or irrigation specialist.
- Option 3: Irrigation by hand. If this option is chosen, an inspection may be required once a year during the three-year establishment period, after the final construction inspection, to ensure that the vegetation in the Landscaped Area(s) is in good health. If it is deemed that the required vegetation is not in good health including conditions such as excessive pruning, death or damage to the natural growing form of the plant, or significant reduction of the plant function, provisions in TMC 13.06.090B and 13.05.150 enforcement including, but not limited to, fines and plant replacement may be enacted.

Refer to Appendix 3 for an approved Sample Landscape Management Plan template.

## Chapter 7 Tree Protection During Construction

Urban trees need to be protected from damage to maximize their health, safety, benefits and functionality. Mature, young and newly transplanted trees need protection from construction activities. Tree protection involves activities designed to preserve and protect tree health by avoiding damage to tree parts such as roots, trunk and crown.

This Chapter describes mandatory actions for construction activities around existing trees that are to be retained to comply with TMC 13.06.090B landscaping requirements, TMC 9.20, or for Stormwater Flow Control credits per the City of Tacoma Stormwater Management Manual. For more information on tree protection during construction, the following resources are suggested:

- [Tree Protection on Construction and Development Sites- A Best Management Practices Guidebook for the Pacific Northwest](#)
- American National Standards Institute (ANSI) A300 (Part 5) -Construction Management Standard
- International Society of Arboriculture Best Management Practices (BMP)- [Managing Trees During Construction](#)

## 7.1 Tree Protection Areas

Figure 7-1: Tree Protection Areas

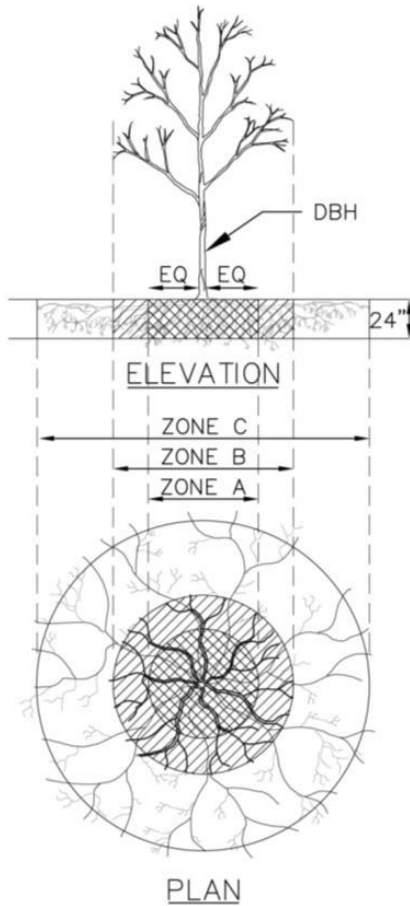

### (Zone A) Critical Root Zone (CRZ)

“Critical root zone” means the area around and under a tree. The radius of the Critical Root Zone measures 1 foot per 1 inch of diameter at breast height (DBH) from the trunk outwards and twenty-four inches in depth. For example, for a 10 inch DBH tree, the Critical Root Zone is located at least 10 feet out from the trunk and 24 inches deep.

2 inches	2 feet	4 feet + tree trunk
6 inches	6 feet	12 feet + tree trunk
20 inches	20 feet	40 feet + tree trunk
50 inches	50 feet	100 feet + tree trunk

### (Zone B) Drip Line

“Drip line” is the area on the ground below the tree with a boundary designated by the edge of the tree’s crown. Refer to glossary for definition of tree crown. For young trees, Zone A and B may be one and the same.

### (Zone C) Feeder Root Zone

“Feeder Root Zone” is the area under and around a tree. The radius of the Feeder Root Zone measures 2 feet per one inch of DBH from the trunk outwards and 24 inches in depth. For example, for a 10 inch DBH tree, the Feeder Root Zone is located at least 20 feet out from the trunk and 24 inches deep.

### Tree Protection Zone (TPZ)

“Tree Protection Zone” is an Arborist defined area surrounding the trunk intended to protect the roots and soil to ensure future tree health and stability. A TPZ consists, at a minimum, of Zone A or B, whichever is greater, or may be another area (typically larger) as defined by the Arborist. Fencing may not be required in portions of the Tree Protection Zone that are covered by pavement, that will remain undisturbed during the construction activities, but other restrictions and protection measures are required as discussed in this Chapter.

## 7.2 Tree Protection Plans

Any person conducting construction activities such as: excavation, filling, tunneling, trenching, compacting, demolition, utility work or other land disturbing activity in the Critical Root Zone or Drip Line of any tree, must submit a Tree Protection Plan to be approved by the City prior to commencement of work if the trees are to be retained to comply with TMC 13.06.090B, TMC 9.20, or for Stormwater Flow Control credits per the City of Tacoma Stormwater Management Manual. The tree protection site plan shall be incorporated into the demolition and temporary erosion and sediment control plans.

Tree Protection Plans shall include each of the following elements:

1. An Arborist Report (refer to Appendix 4), detailing the tree's(s') health, condition and recommendation for or against retention; and
2. A site plan that is drawn to scale and shows:
  - all trees to be preserved on the site including their species, diameter at breast height (DBH) and Tree Protection Zone (including required fencing location);
  - location of existing and/or proposed utilities;
  - proposed grade changes and cross-sections; and,
  - location of proposed new trees.

For an approved Sample Tree Protection Plan refer to Appendix 4.

## 7.3 Alternative Tree Protection Plans

If the requirements for a Tree Protection Plan contained in this Chapter cannot be met, an alternative Tree Protection Plan may be submitted by an Arborist. The Alternative Tree Protection Plan must show alternative means for achieving tree protection and include a statement by the Arborist that the plan provides the same level of protection as the requirements in this chapter. The City will make the final decision on whether an alternative plan is acceptable based on the likelihood of the construction impacts affecting the tree's health and stability.

## 7.4 Tree Protection Fencing

Any person engaging in work that requires a Tree Protection Plan, or any person causing such work to be performed, must ensure that trees shall be sufficiently guarded and protected by those responsible for such work.

Requirements for tree protection fencing for trees to be preserved during construction are as follows:

1. Trees not located directly adjacent to retained pavement (refer to Standard Detail LS-09):

- Erect readily visible 6 foot high chain link fencing at the edge of the Tree Protection Zone, and at the boundary of any open space tracts or conservation easements that abut the construction site except where, due to space restrictions, a specific distance is specified and approved by the Arborist/City.
  - The fencing shall be secured by 6 foot metal posts with movable footings located above ground.
2. Trees located directly adjacent to retained pavement (refer to Standard Details LS-10 and LS-11):
- Erect readily visible chain link or reusable temporary tree and landscape protection fencing (such as high visibility fencing, plywood or similar fencing material) at the edge of the tree well/planting strip or at a minimum width of 4 feet on all sides, whichever is greater.
  - All fencing height shall be between 4 feet to 6 feet high. Chain link fencing shall be secured by metal posts with movable footings located above ground. Metal posts shall not be more than 10 feet apart.
3. All trees regardless of location:
- 1) Fencing shall be flush with the initial undisturbed grade.
  - 2) Tree Protection Signs (Appendices 5 and 6) shall be attached to the fencing. Maintain the fencing in place until the City authorizes removal or a final certificate of occupancy is issued, whichever occurs first. DO NOT affix signs to trees.
  - 3) Ensure that any clearing, grubbing or landscaping done in the TPZ, subsequent to the removal of the fencing, shall be accomplished with light machinery (ex. sod cutter) or hand labor.
  - 4) No construction activity shall occur within the TPZ without prior written approval from the City. If construction activities are desired to be conducted within the TPZ, the City shall be given at least 24 hour notice prior to the anticipated commencement of construction activities. Prohibited work needing approval includes but is not limited to:
    - dumping of construction waste;
    - storage of materials;
    - storage of vehicles or equipment;
    - trenching;
    - changing soil grade;
    - compacting soil with vehicle or equipment traffic;
    - installing pavement of any kind;
    - attaching anything to trees using nails, crews and/or spikes; or,
    - causing injury by fire or excessive heat.

Penalties pursuant TMC 13.06.090B, 13.05.150, and 9.20 are applicable for non-compliance with this Chapter.

For Tree Protection Zone fencing standard plans, refer to Standard Plans LS-09, LS-10 and LS-11. For standard Tree Protection Zone Signs, refer to Appendices 5 and 6.

## 7.5 Working in the Tree Protection Zone – Protective Measures

While certain construction activities are limited or prohibited within the TPZ, it is recognized that some activities cannot be avoided. If any construction activities are to be conducted within the TPZ, the following protective measures shall be conducted.

### 7.5.1 Surface Protection Measures

If traffic and construction activities cannot be kept out of the Tree Protection Zone for the entire duration of construction, actions shall be taken to disperse the vehicular load and/or surface compaction to protect the roots and minimize root damage.

Surface Protection Measures include:

1. applying 6 to 12 inches of wood chip mulch to the area;
2. laying ¾-inch plywood over 4 x 4 wood beams over a 4-inch thick layer of wood chip mulch;
3. applying 4 to 6 inches of gravel over a taut, staked geotextile fabric;
4. placing steel plates on top of a 4-inch thick layer of wood chip mulch; or,
5. placing commercial or logging road mats on top of a 4-inch thick layer of wood chip mulch.

### 7.5.2 Trunk Protection Measures

If traffic and construction activities cannot be kept out of the TPZ for the entire duration of construction, actions shall be taken to protect the trunk from incurring damage.

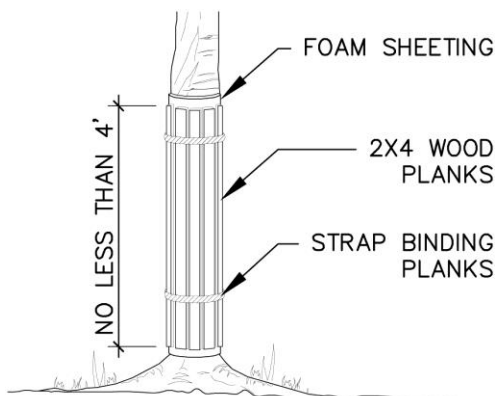

Trunk Protection Measures:

Install 2-inch thick wood planks around the trunk of the tree with ¼" or greater closed-cell foam pads between the trunk and planks. The height of the wood planks shall be 4 feet minimum, or match the height of the vehicle clearance, whichever is greater. Use straps or wire to bind the planks in place. DO NOT drive fasteners into the tree. If the protective planks are to be in place for longer than 6 months, loosen and adjust the planks every 3 months to allow for growth.

### 7.5.3 Supplemental Irrigation

If construction activities are conducted within the TPZ during the months of May through September supplemental irrigation, which could include hand watering or another regular source of water, shall be provided. Trees shall be irrigated to provide at least 1 inch of water applied once a week directly to the root system using a slow delivery method to allow for adequate infiltration. The delivery method shall be identified on the work plan.

All trees elected to be retained through construction shall be monitored for signs of drought stress. Signs of drought stress include:

- Leaf curling or rolling
- Leaf drop
- Early fall color
- Dieback on leaders (esp. in conifers).

If signs of drought stress persist or worsen after providing regular irrigation, promptly notify the City's Planning and Development Services at (253) 591-5030.

### 7.5.4 Canopy/Clearance Pruning

If canopy/clearance pruning is required to provide adequate clearance for construction equipment, the crown raising method of pruning shall be applied to achieve clearance. Typical vehicular clearance is 14 feet over vehicular trafficked areas. If trees to be pruned are located within the public right-of-way, a Permit pursuant to TMC 9.20 is required prior to performing any tree pruning.

Where excessive pruning would be necessary for construction clearance, temporary tie-up of lower limbs may be considered appropriate so long as the limbs are not structurally damaged.

## 7.6 Working in the Tree Protection Zone – Trenching/Excavation

### 7.6.1 General

Boring /Tunneling/Jacking is permitted in all Zones providing that:

1. All soil disturbance is at a minimum depth of 2 feet below grade;
2. The receiving / insertion point is not located within Zones A and B; and,
3. The diameter of the tunnel is not to exceed 6 inches.

### 7.6.2 Zone A (Critical Root Zone)

1. No disturbance allowed without site-specific inspection and approval of methods to minimize root damage, except in the case of tunneling / boring / jacking.
2. Severing roots larger than 2 inches in diameter requires City approval.
3. Tunneling/boring/jacking is required to install lines 3 feet below grade or deeper.

### 7.6.3 Zone B (Drip Line)

1. Operation of heavy equipment and/or stockpiling of materials are subject to City approval, and requires specific surface protection measures, refer to [Section 7.5.1](#).
2. Trenching may be allowed if adhering to the following:
  - excavation by hand or with a hand-driven trencher may be required;
  - trench width must be limited;
  - no disturbance in Zone A is allowed; and,
  - 2/3 or more of Zone B must be maintained in an undisturbed condition.
3. Tunneling may be required for trenches deeper than 3 feet.

### 7.6.4 Zone C (Feeder Root Zone)

1. Operation of heavy equipment and/or stockpiling of materials is subject to City approval, and may require specific surface protection measures, refer to [Section 7.5.1](#).
2. Trenching is allowed with strict adherence to the following:
  - excavation by hand or with a hand-driven trencher may be required;
  - trench width must be limited;
  - no disturbance in Zone A is allowed; and,
  - 2/3 or more of Zone C must be maintained in an undisturbed condition.

For tree protection during construction standard plans, refer to Standard Plans LS-08, LS-09, LS-10 and LS-11.

## 7.7 Critical Root Zone – Prohibited Construction Activities

The following activities are prohibited within the Critical Root Zone:

- Dumping or storing materials such as building supplies, soil, waste items, vehicles or equipment;
- Parking vehicles;
- Excavating for utility or building construction;
- Constructing new paved surfaces; and
- Significant changes to the grade or drainage patterns to the tree(s).

Any landscaping done in the CRZ subsequent to the removal of the fencing shall be accomplished by hand operated equipment or, when not feasible to be done by hand, shall be conducted with the smallest mechanized equipment necessary.

## 7.8 Post-Construction Tree Monitoring

All trees retained through construction shall be monitored and maintained including mulching, irrigation and pruning where necessary, for the next 3 years following construction. Trees shall be inspected annually to look for changes in condition and signs of pests or disease. If symptoms persist or worsen, promptly notify the City's Planning and Development Services at (253) 591-5030.

Ongoing protection activities following construction include:

- maintaining a mulched, grass-free area around the trunk to avoid damage by mowers or string trimmers;
- keeping building and other maintenance activities away from the limbs and trunks of trees during repair projects;
- avoiding soil contamination from oil, gasoline, paint, paint thinner, or other chemicals; and,
- not attaching wires, cables, conduit, mailboxes or other objects to the trees.

## Glossary

In addition to the terms contained in the definitions section of Tacoma Municipal Code (TMC) 13.01, the following terms shall be used according to the following definitions.

“Amenity Space.” Amenity space provides residents access to areas for relaxation, recreation, and socializing. These include both private and common spaces both indoor or outdoor. Examples of private amenity space include balconies, porches, decks, patios, and yards. Examples of common amenity spaces include courtyards, rooftop decks, gardens, play yards, and park greens.

Annual: An annual plant germinates, flowers, seeds and dies (completes its lifecycle) within one year.

“ANSI A300” shall mean and refer to the most current version of the tree, shrub and other woody plant maintenance and standard practices standard A300 as accredited by the American National Standards Institute (ANSI) or its successor organization.

ANSI Z60.1 Standards: Industry developed standards for nursery stock sizing and describing plants to facilitate the trade in nursery stock; acronym for American National Standards Institute.

ANSI Z133.1: Industry developed safety standards for tree care operations.

Arborescent Shrub: A woody stemmed plant usually free branching from the base, which can reach heights of 15 to 20 feet. Whereas a tree usually has a single stem, an Arborescent Shrub has several stems arriving at or near the ground.

“Arborist” or “Certified Arborist” shall mean and refer to an individual engaged in the profession of arboriculture who, through experience, education and related training, possesses the competence to provide for or supervise the management of trees and other woody plants, and shall have the credential of Certified Arborist as granted by the International Society of Arboriculture (ISA). Certified Arborists must maintain their certification and be in good standing with the International Society of Arboriculture.

Balled and Burlapped Stock: Plants dug with firm, natural balls of earth in which they were grown, with ball size not less than diameter and depth recommended by ANSI Z60.1 for type and size of plant required; wrapped with burlap, tied, rigidly supported, and drum laced with twine with the root flare visible at the surface of the ball as recommended by ANSI Z60.1.

Bare Root Stock: Plants grown in the ground in the nursery without artificial root restriction devices, such as containers or fabric bags. When dug the soil is removed from the root systems and the plants are transported and sold without soil.

“Best management practices” or “BMPs” shall mean and refer to the standard practices for tree pruning and removal approved or recommended under ANSI A300.

**Caliper:** Diameter of a tree's trunk or stem measured at a point 6 inches above finish grade if the resulting measurement is up to and including 4 inches. If the resulting measurement is more than 4 inches the point of measurement shall be relocated to 12 inches above finish grade.

**Canopy Factor:** A method of calculating tree size by taking into account the tree's mature height, mature crown spread and growth rate. The Canopy Factor is calculated using the following formula: (mature height in feet) x (mature crown spread in feet) x (growth rate number) x 0.01 = Canopy Factor. The growth rate number is 1 for slow growing trees, 2 for moderately growing trees, and 3 for fast growing trees.

- Large Trees = Canopy Factor greater than 70
- Medium Trees = Canopy Factor from 40 to 70
- Small Trees = Canopy Factor less than 40

**Central Branch; Central Leader:** A singular, dominant, upright branch or stem which does not have any stems arising from a common junction having nearly the same size and diameter.

**Certified Arborist:** An individual who has achieved a level of knowledge in the art and science of tree care through experience and by passing a comprehensive examination developed by some of the nation's leading experts on tree care. Certified Arborists must maintain their certification and be in good standing with the International Society of Arboriculture (ISA), or equivalent agency.

**Climate adapted:** Both native and non-native plant species which are able to thrive in the local climate and soil conditions of a specific region. The two most authoritative references on climate adaptation for plants are the USDA Plant Hardiness Zones and the Sunset Climate Zones. Plants that are considered climate adapted shall be selected in accordance with one or both of these resources.

**Codominant Branches; Codominant Leaders:** Branches of stems arising from a common junction, having nearly the same size diameter.

**Container-Grown Stock:** Healthy, vigorous, well-rooted plants grown in a container, with a well-established root system reaching sides of container and maintaining a firm ball when removed from container. Container shall be rigid enough to hold ball shape and protect root mass during shipping and be sized according to ANSI Z60.1 for type and size of plant.

**Cultivar:** Contraction of "cultivated variety". A group of plants within a species having distinct differences that retain those characteristics when reproduced sexually or asexually.

**Critical Root Zone (CRZ):** The area under a tree whose diameter measures one foot per one inch of DBH from the trunk outwards and twenty-four inches in depth.

**Deciduous:** A plant that loses its leaves and remains leafless for some months of the year, usually in winter (temperate zones) or the dry season (tropical zones).

“DBH”, “DSH”, or “caliper inches” shall mean diameter at breast height, or diameter at standard height, which refers to the tree trunk diameter measured at four feet six inches (4’-6”) above the ground of a standing tree, measured in inches and tenths of an inch. If the tree is measured at less than four inches (4”) of DBH or DSH, as is typical for newly planted trees, caliper inches shall be used, and is measured at six inches (6”) above the soil level.

“Design manual” shall mean and refer to the manual applicable to construction of all street and right-of-way improvements as adopted by the City Director of Public Works, and effective on or about January 7, 2016, and any amendments, updates, or revisions made thereto, and on file with the Public Works Department.

Drip Line: The area on the ground below the tree in which the boundary is designated by the edge of the tree’s crown.

Duff Layer: The surface layer of native topsoil that is composed of mostly decayed leaves, twigs, and detritus.

Establishment Period: A minimum of a three year time period following the transplanting/installation of vegetation wherein maintenance is critical to the survival of the vegetation.

Evergreen: A plant that bears leaves throughout the year.

Fabric Bag-Grown Stock: Healthy, vigorous, well-rooted plants established and grown in-ground in a porous fabric bag with a well-established root system reaching sides of fabric bag. Fabric bag size is not less than diameter, depth, and volume required by ANSI Z60.1 for type and size of plant.

Feeder Root Zone: The area under a tree whose diameter measures two feet per one inch of DBH from the trunk outwards and twenty-four inches in depth. For example, for a ten-inch DBH tree, the Feeder Root Zone is at least twenty feet in diameter and 24” deep.

Finish Grade: Elevation of finished surface of planting soil.

“Fruit Tree” shall mean and refer to a tree that is grown for its edible fruit, consumed by humans. Ornamental varieties of fruiting trees, such as ornamental pear or cherry trees, are exempt from the definition of a fruit tree.

Genus (pl. genera): A group of plants within a family that is morphologically similar and contains one of more species.

Groundcover: Low and dense growing plants that cover the ground which can be planted for ornamental purposes, habitat or to prevent soil erosion. Turf lawn and mulch do not count as groundcover.

Hardiness Zones; USDA Plant Hardiness: Developed by the U.S. Department of Agriculture, Plant Hardiness Zones divide North America into geographic zones based on average winter lows.

“Hazardous tree” and “hazard tree” shall mean and refer to a tree(s) that is found to be likely to fail and has an extreme or high risk to cause property damage, personal injury or fatality in the event of a failure. Trees designated as hazards shall be designated as such by a Certified Arborist who has achieved a Tree Risk Assessment Qualification.

“Heritage tree(s)” shall mean and refer to a tree, or collection of trees, located in the City limits of Tacoma that, because of exemplary size, age, cultural/historical significance, ecological value, or rarity, is considered irreplaceable.

Invasive tree: A tree species that was introduced by humans to locations outside of the tree’s native range that spread and persist over large areas. Invasive species negatively impact natural ecosystems by displacing native species, reducing biological diversity, and interfering with natural succession.

Invasive Weeds; Noxious Weeds: Non-native plant species which have been proven to have a negative impact on the environment and are highly destructive, competitive, and difficult to control or eliminate. For a current listing of Pierce County Invasive/Noxious weeds consult the Pierce County Noxious Weed Control Board.

Manufactured Topsoil: Soil produced off-site by homogenously blending mineral soils or sand with stabilized organic soil amendments to produce topsoil or planting soil.

Perennial: A plant having a life cycle lasting three or more years.

Permanent Roadway: Roadway constructed with a designed full depth subgrade and road surface section with an established curb and gutter alignment.

Pesticide: A substance or mixture intended for preventing, destroying, repelling, or mitigating a pest. This includes insecticides, herbicides, fungicides, rodenticides, and molluscicides.

Pests: Living organisms that occur where they are not desired, or that cause damage to plants, animals, or people. These include insects, mites, grubs, mollusks (snails and slugs), rodents (gophers, moles, and mice), unwanted plants (weeds), fungi, bacteria, and viruses.

Planting Area: Locations on private property or the public right-of-way proposed or required to be planted.

Planting Soil: Standardized topsoil; existing, native surface topsoil; existing, in-place surface soil; imported topsoil; or manufactured topsoil that that may be modified with soil amendments to produce a soil mixture best suited for plant growth.

“Planting strip” shall mean and refer to that portion of an improved right-of-way between the street curb or edge of the traveled portion of roadway and the property line of the abutting property available and used for the purpose of planting and maintaining street trees and other vegetation.

Plants; Plant; Plant Material: These terms refer to vegetation in general, including trees, shrubs, vines, groundcovers, ornamental grasses, bulbs, corms, tubers, or herbaceous vegetation.

“Prune” or “pruning” shall mean and refer to the removal of plant parts, dead or alive. In no circumstance does tree topping qualify as appropriate tree pruning.

Right-of-Way or Rights-of-Way (ROW) Per TMC 13.01: The public streets, roadways, courts, alleys and any other public passages, whether developed or undeveloped, over which the City has a possessory interest or right of use either by easement, license, permit or other such authority, or by fee simple ownership. For purposes of this definition developed rights of way may contain items such as pavement, parking or loading areas, retaining walls or other structures, landscape or planting strips, sidewalks, curbs, vehicle, bicycle or pedestrian traffic lanes, traffic circles and other such development. This definition is intended to be construed so as to be consistent with other definitions of the term Right-of-Way or Rights-of-Way as may be found in Tacoma Municipal Code or Washington State statutory and case law.

Root Flare: Also called “trunk flare.” The area at the base of the plant’s stem or trunk where the stem or trunk broadens to form roots; the area of transition between the root system and the stem or trunk.

“Significantly damaged tree” shall have the meaning as that term is given at TMC 9.20.220.

Shrub: A woody perennial plant that is generally less than fifteen feet in height at maturity.

Stem Girdling Roots: Roots that encircle the stems (trunks) of trees below the soil surface.

Street tree: A planted tree, or tree that is intended to be planted, whose trunk is wholly or partially located within the public right-of-way. Street trees may be owned by the City or by an abutting property owner

Subgrade: Surface or elevation of subsoil remaining after excavation is complete, or the topsoil surface or a fill or backfill before planting soil is placed.

Subsoil: All soil beneath the topsoil layer of the soil profile, and typified by the lack of organic matter and soil organisms.

Sunset Climate Zones: Geographic regions which are divided according to their total climate. This total climate is governed by the length of growing season, timing and amount of rainfall, winter lows, summer highs, wind, and humidity.

Surface Planting Diameter: The minimum dimension of a tree planting area in any direction, provided suspended pavement systems are used to meet required soil volume underground.

Surface Soil: Soil that is present at the top layer of the existing soil profile at the project site. In undisturbed areas, the surface soil is typically the topsoil; but in disturbed areas such as urban environments, the surface soil can be subsoil.

**Suspended Pavement Systems:** Suspended pavement systems, or SPS, reference a technology that structurally supports paving over planting soil to allow growth of tree roots directly underneath paving. In addition to aiding urban tree growth, the soil can also be used for on-site stormwater management, maintaining pre-development hydrology, minimizing non-point source pollution and flooding, and recharging watersheds.

**“Topping” or “Tree Topping”:** An unacceptable tree pruning practice, which injures trees through the reduction of a tree’s size by pruning live branches and leaders to stubs, without regard to long-term tree health or structural integrity. Topping can lead to unacceptable risk, tree stress, and decay.

**Tree:** Any self-supporting woody perennial that generally matures over fifteen feet in height, generally has a minimum mature canopy width of ten feet and greater, and is capable of being shaped and pruned to develop a branch-free trunk to at least eight feet in height at maturity.

**Tree Canopy Credit:** Tree Canopy Credits quantify the value of a tree’s canopy for the purposes of defining how many trees are required on a site.

**Tree Protection Zone (TPZ):** The area surrounding the trunk of a tree intended to protect roots and soil within the Critical Root Zone and beyond, to ensure future tree health and stability. The location of the Tree Protection Zone is at the edge of the Critical Root Zone or Drip Line, whichever is greater.

**Tree sizes:** Categorized as Large, Medium or Small as determined by the Canopy Factor, which takes into account the trees mature height, mature crown spread and growth rate.

**Unpaved Surface Planting Diameter:** The minimum dimension of a tree planting area in any direction, provided suspended pavement systems are used to meet required soil volume underground.

**Urban Horticulture:** A use in which plants are grown or produced indoors for the sale of the plants or their products or for use in any business, including such things as fruits, vegetables, and other crops, flowers, ornamental plants or trees.

**Variety:** A group of plants within a species having distinct differences that occur naturally and usually within a specific geographic region.

## Appendices

Appendix 1	Landscaping Calculations Worksheets: Summary
Appendix 1A	Overall Site Landscaping Calculations Worksheet
Appendix 1B	Site Perimeter Landscaping Calculation Worksheet
Appendix 1C	Parking Lot Landscaping Calculation Worksheet
Appendix 1D	Landscape Buffer Calculation Worksheet
Appendix 1E	X District Front Yard and Foundation Landscaping Calculation Worksheet
Appendix 1F	Required Tree Canopy Credits Worksheet (UR Zones)
Appendix 2	Sample Landscaping Plan
Appendix 3	Landscape Management Plan (LMP) Template
Appendix 4	Sample Tree Protection Plan and Sample Arborist Report
Appendix 5	Tree Protection Zone Sign – General
Appendix 6	Tree Protection Zone Sign – For Trees in Paved Areas
Appendix 7	Tree Lists
Appendix 7A	Approved Large Tree List
Appendix 7B	Approved Medium Tree List
Appendix 7C	Approved Small Tree List
Appendix 7D	Prohibited and Not Recommended Tree List
Appendix 8	Urban Residential Tree Requirements Summary
Appendix 9	Urban Residential Case Study
Appendix 10	Plan Submittal Checklist

## Appendix 1: Landscaping Calculation Worksheet: Summary

Overall Site Landscaping		
1. Area not covered by structures		SF
2. Landscaping area required		SF
Required Tree Canopy Credits		
Parcel Area		SF
Tree Canopy Credits Required		
Proposed Trees	Number	Species
Small Trees		
Medium Trees		
Large Trees		
Street Trees		
1. Street Trees Required		
2. Site Frontage		LF
3. Required Trees	Number	Species
Small Trees		
Medium Trees		
Large Trees		

Parking Lot Landscaping		
1. Parking Lot Landscaping is Required		
2. Total Area of Parking Lot		SF
3. Interior Planting		
Total Trees Required		
Flexibility Options Used:		
Landscaped Areas	Number	Total SF
Small Trees		
Medium Trees		
Large Trees		
Total Interior Landscape Area		SF
Credits and Flexibility		
Tree Retention		
Evergreen Trees		
Tree Bank		

**Plant Schedule (TYP)**

Symbol	Botanical Name	Common Name	Container Caliper	Size	Quantity	Detail	S/M/L	PNW Native?

## Appendix 1A: Overall Site Landscaping Calculations Worksheet

<b>Overall Site Landscaping Worksheet:</b>			
STEP 1: Determine site area not covered by structures			
Total site area	Area covered by structures	Area not covered by structures	
_____ sf -	_____ sf =		
		_____ sf	
STEP 2: Determine total Overall Site Landscaping area required			Total Overall Site Area landscaping required
5% x			= _____ sf
<p>NOTES:</p> <ul style="list-style-type: none"> <li>• If other required landscaping is equal to or greater than this amount, then no further landscaping is required.</li> <li>• Shrubs and groundcover to fully cover area within 3 years.</li> </ul>			

## Appendix 1B: Site Perimeter Landscaping Calculation Worksheet

<b>STEP 1: Determine if Site Perimeter Landscaping is required</b>			
Not required in Urban Residential, Industrial or X Districts.			
<ul style="list-style-type: none"> <li>• 7 feet wide for sites without abutting street trees</li> <li>• 5 feet wide for sites with street trees or less than 150 feet in depth</li> </ul>			
<b>STEP 2: Determine total area of Site Perimeter Landscaping</b>			
Length of site frontage x 7 or 5 feet width (– areas not planted) = _____			
<b>STEP 3: Determine required number of Small, Medium and/or Large Tree Species</b>			
Total Site Perimeter Trees required			
_____ sf –	_____ Small Trees x 200 sf	_____ Medium Trees x 300 sf	_____ Large Trees x 400 sf
<b>NOTES:</b> <ul style="list-style-type: none"> <li>• Shrubs and groundcover to fully cover area within 3 years.</li> </ul>			

## Appendix 1C: Parking Lot Landscaping Calculation Worksheet

<b>STEP 1: Determine if Parking Lot Landscaping is required</b>			
In M-2 or PMI Districts, Parking Lot Perimeter landscaping is <b>not</b> required.			
In Urban Residential (UR) Districts, Perimeter landscaping is only required between parking lots and streets.			
Parking lots of 16 stalls or less are not required to meet Interior Planting requirements.			
Parking lots of 16 stalls or less, located behind buildings and accessed by alleys, are exempt from the Interior Planting and Site Perimeter requirements.			
<b>STEP 2: Determine Parking Area tree minimum – Overall</b>			
Total area of parking lot: _____			
Total area of parking lot ≤		The sum of:	
_____ sf	_____ Small Trees x 700 sf	_____ Medium Trees x 1,000 sf	_____ Large Trees x 1,400 sf
NOTE:			
<ul style="list-style-type: none"> <li>If other required parking lot landscaping is equal to or greater than this amount, then no further landscaping is required.</li> </ul>			
<b>STEP 3: Determine Parking Lot – Interior Planting requirements</b>			
Tree Distribution requirements:			
<ul style="list-style-type: none"> <li>No stall shall be more than 50 feet from a tree trunk</li> <li>Long rows of parking shall be broken by islands or peninsulas with trees, such that there are no more than eight parking stalls in a row without a tree.</li> <li>Planting areas with trees are required at all parking aisle ends.</li> <li>At least one Small Tree per 200 sf, one Medium Tree per 300 sf, or one Large Tree per 400 sf of landscaped area.</li> <li>Trees planted shall be generally evenly distributed over the site.</li> </ul>			
TOTAL TREES REQUIRED: _____			

**Tree Distribution flexibility:**

Maximum distance between trees increase by 10 ft AND maximum row length by 1 stall for each of the following provided:

- Tree retention (at least 50% of tree requirements met through retaining trees greater than 20 inches DBH)
- Evergreen trees (greater than 2/3 of required trees)
- LID as primary stormwater technique

Once total number of trees is determined, utilize Minimum unpaved planting area requirement to determine total interior parking lot landscaped area:

- 24 sf per Small Tree planted
  - 40 sf per Medium Tree planted
  - 60 sf per Large Tree planted
- = \_\_\_\_\_ sf total Parking Lot Interior Planting Requirements

**Determine Small, Medium and Large Trees required:**

Interior Parking Lot Area:  _____ sf –	_____ Small Trees x 200 sf	_____ Medium Trees x 300 sf	_____ Large Trees x 400 sf
--	-------------------------------	--------------------------------	-------------------------------

**NOTE:**

- Shrubs and groundcover to fully cover area within 3 years.

**STEP 4: Parking Lot – Perimeter Planting requirements**

**Determine Parking Lot – Perimeter Planting is requirements:**

All lots greater than 20 stalls:

- 10 foot perimeter required
- 5 foot perimeter width if less than 150 foot deep site

**EXCEPTIONS:**

- Exceptions for parking lots less than 15 and behind buildings adjacent to alleys.

**Determine total area of Parking Lot Perimeter:**

Parking lot circumference x perimeter width (5 or 10 feet) = \_\_\_\_\_ sf

**Determine Small, Medium and Large Trees required:**

Parking Lot – Perimeter Area:  _____ sf –	_____ Small Trees x 200 sf	_____ Medium Trees x 300 sf	_____ Large Trees x 400 sf
---	-------------------------------	--------------------------------	-------------------------------

**NOTE:**

- Shrubs and groundcover to fully cover area within 3 years.

## Appendix 1D: Landscape Buffer Calculation Worksheet

<b>STEP 1: Determine if Buffers are required</b>			
<b>Not</b> required in Urban Residential districts.			
More intensive district abutting an R-District: <ul style="list-style-type: none"> <li>• 15 foot wide buffer</li> <li>• 10-foot wide buffer for sites less than 150 feet deep</li> </ul>			
More intensive district across street or alley from R District: <ul style="list-style-type: none"> <li>• 7 foot wide buffer</li> <li>• May be reduced to 4-feet with vegetated fence or wall.</li> </ul>			
Determine if exceptions apply			
<b>STEP 2: Determine total area of Buffer planting</b>			
Length of required buffer _____ x width _____ (15, 10, 7 or 4 feet) = _____			
<b>STEP 3: Determine required planting</b>			
Planting when abutting R-District: <ul style="list-style-type: none"> <li>• See TMC 13.06.090.J.5 for tree number and spacing requirements.</li> </ul>			
Plantings across street or alley from R-District: <ul style="list-style-type: none"> <li>• Total Buffer Trees required:</li> </ul>			
_____ sf –	_____ Small Trees x 200 sf = _____	_____ Medium Trees x 300 sf = _____	_____ Large Trees x 400 sf = _____
NOTES: <ul style="list-style-type: none"> <li>• Mobile home/trailer court exceptions</li> <li>• See the TMC for species and spacing requirements</li> <li>• Shrubs and groundcover as specified in TMC 13.06.090B .</li> </ul>			

## Appendix 1E: X District Front Yard and Foundation Landscaping Calculation Worksheet

### STEP 1: Determine if required

- X Districts only
- When buildings are set back from sidewalk

### STEP 2: Determine shrubs and groundcover required

- Landscaped area to be at least 3 feet wide
- Cover exposed foundations
- One shrub per three lineal feet of foundation
- Groundcover plants to cover the remainder of landscaped area.

## Appendix 1F: Required Tree Canopy Credits Worksheet (UR Zones)

<b>Step 1: Determine required Tree Canopy Credits*</b> See <a href="#">Section 2.2</a>				<b>Total Required</b>
Total Parcel Area:	Percentage of Tree Canopy Credits Required by Zone UR-1: 30% UR-2: 25% UR-3: 20%			Required Tree Canopy Credits
_____ sf	x _____%			=
<b>Step 2: Credits for Retained Trees</b> See <a href="#">Section 2.2.4</a> Note: Calculate each tree individually				<b>Total Retained</b>
Credits for retained trees < 6" DBH	Credits for retained trees 6" ≤ 12" DBH	Credits for retained trees 12" ≤ 24" DBH	Credits for retained trees > 24" DBH	Sum of Retained Tree Canopy Credits
_____ in x 50 credits/in = _____	_____ in x 75 credits/in = _____	_____ in x 100 credits/in = _____	_____ in x 125 credits/in = _____	=
<b>Step 3: Credits for New Trees</b> See <a href="#">Section 2.2.3</a>				<b>Total Planted</b>
Credits for Small Trees Planted	Credits for Medium Trees Planted	Credits for Large Trees Planted		Sum of New Tree Canopy Credits
____ Small Trees x 200 credits per tree = _____	____ Medium Trees x 500 credits per tree = _____	____ Large Trees x 1,000 credits per tree = _____		=
<b>Step 4: Credits for Extra Street Trees (if applicable)</b>				<b>Extra Credits</b>
Credits calculated in <a href="#">Section 3.1.2</a>				=
<b>Step 5: Determine the Total Tree Canopy Credits Provided</b>				<b>Total Provided</b>
Sum of Retained Tree Canopy Credits, New Tree Canopy Credits, and Extra Street Tree Canopy Credits				=

\*A project meets required Tree Canopy Credits if the total Tree Canopy Credits provided in the lower right cell is greater than or equal to the required Tree Canopy Credits in the upper right cell.

## Appendix 2: Sample Landscape Plan

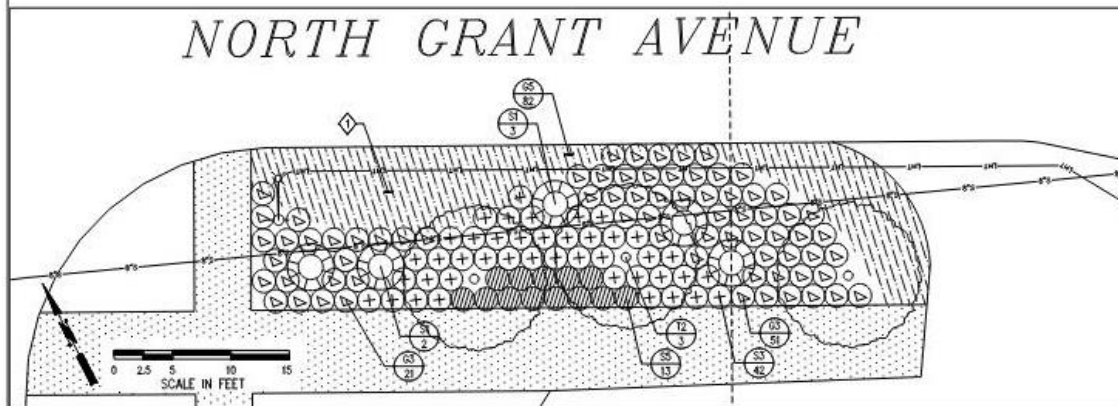
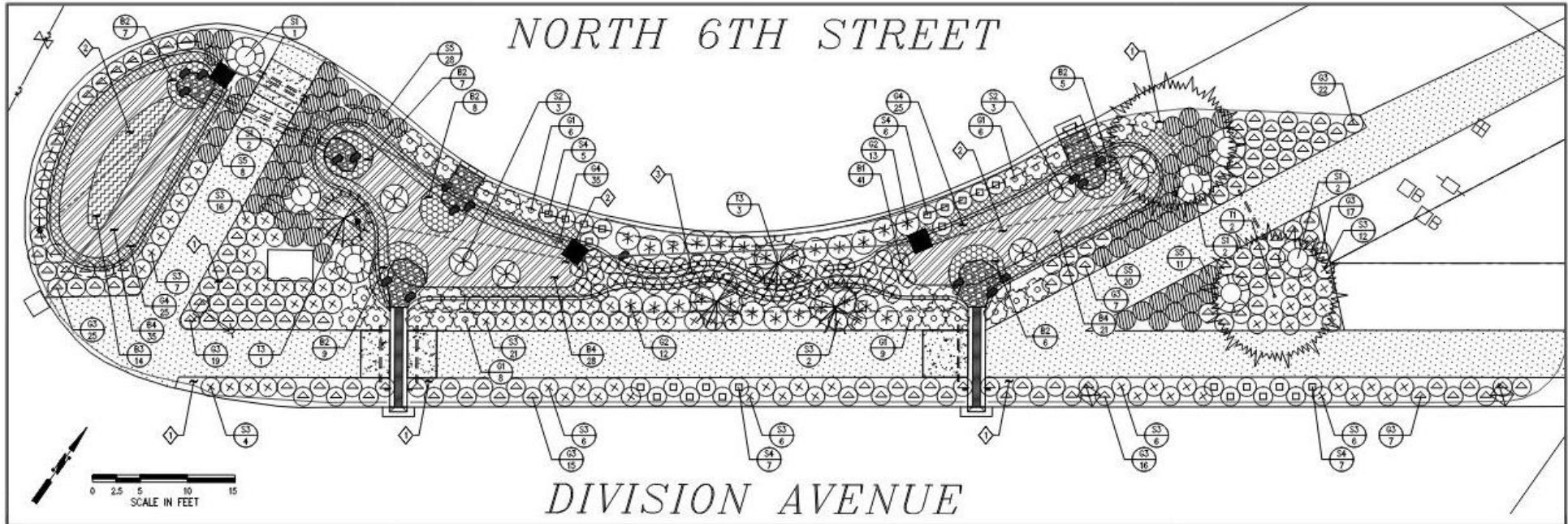

### CONSTRUCTION NOTES

- ◆ SOIL AMENDMENT TYPE 4. SCARIFY OR TILL SUBGRADE TO 6-INCH DEPTH. PLACE 5-INCHES OF FAGRO TOPSOIL ON SURFACE AND TILL INTO 4-INCHES OF SITE SOIL. PLACE 3-INCHES FAGRO TOPSOIL ON SURFACE. RET ALL 3 BANK MATCH TYP.
- ◆ BIORETENTION PLANTER. SEE BIORETENTION DETAILS SHEET 3 FOR SOIL, MEDIA AND MULCH DEPTH.
- ◆ SWALE. SEE DETAIL 3, SHEET 3.

CALL 2 DAYS BEFORE YOU DIG  
1-800-424-5555

**CITY OF TACOMA**  
ENVIRONMENTAL SERVICES DEPARTMENT

NO.	REVISION	DATE	APP'D.

DATE	SCALE	BY	CHECKED
3/7/2014	1" = 5'		
DESIGNED		DRAWN	
DATE	PROJECT NAME		
PROJECT NO.	DRAWING NAME		

CITY OF TACOMA  
**ENVIRONMENTAL SERVICES DEPARTMENT**  
615 SPRAGUE BIORETENTION RAIN GARDEN  
LANDSCAPE PLAN

PROJECT NO.  
ENV-03020-14

SHEET NO.  
5 OF 6

PLANT SCHEDULE

SYMBOL	BOTANICAL NAME/ COMMON NAME	SIZE	QTY	REMARKS
<b>TREES</b>				
T1	PINUS FLEXILIS/ LUMBER PINE	4'-5' HT.	2	B&B/WELL-BRANCHED
T2	LAGERSTROEMIA 'NATCHEZ'/ NATCHEZ ORANGE MYRTLE	15 GAL. CONT.	3	WELL-BRANCHED
T3	CHAMAECYPARIS NOOTKATENSIS 'PUNDULA'/ WEEPING ALASKA CEDAR	6'-7'	4	B&B/WELL-BRANCHED
<b>SHRUBS</b>				
S1	FOTHERGILLA GARDENII/ DWARF FOTHERGILLA	3 GAL. CONT.	12	FULL AND BUSHY
S2	PHYSOCARPUS OPUL. 'DART'S GOLD'/ DART'S GOLD NINEBARK	3 GAL. CONT.	6	FULL AND BUSHY
S3	LAVANDULA STOECCHAS 'ANOUK SILVER'/ SPANISH LAVENDER	1 GAL. CONT.	128	24" TRI. SP. TYP.
S4	SEDUM SPECTABILE 'AUTUMN JOY'/ AUTUMN JOY STONECROP	1 GAL. CONT.	25	24" TRI. SP. TYP.
S5	SANTOLINA CHAMAECYPARISSUS/ LAVENDER COTTON	1 GAL. CONT.	80	24" TRI. SP. TYP.
<b>GRASSES/GROUNDCOVERS</b>				
G1	PANICUM VIRGATUM 'HEAVY METAL'/ HEAVY METAL SWITCH GRASS	1 GAL. CONT.	29	30" TRI. SP. TYP.
G2	PENNISETUM ALOPECUROIDES 'HAMELI'/ DWARF FOUNTAIN GRASS	1 GAL. CONT.	25	30" TRI. SP. TYP.
G3	FESTUCA AMETHYSTINA 'SUPERBA'/ AMETHYST FESCUE	1 GAL. CONT.	200	24" TRI. SP. TYP.
G4	FRAGARIA 'LIPSTICK'/ LIPSTICK STRAWBERRY	4" POTS	85	24" TRI. SP. TYP.
G5	GENSTA LYDIA/ DYER'S GREENWOOD	1 GAL. CONT.	82	24" TRI. SP. TYP.
<b>BIORETENTION PLANTS</b>				
B1	CAREX OSHIMENSIS 'EVERCOLOR EVERLLO'/ EVERCOLOR SEDGE	1 GAL. CONT.	41	24" TRI. SP. TYP.
B2	IRIS SIBIRICA 'RUFFLED VELVET'/ RUFFLED VELVET SIBIRIAN IRS	1 GAL. CONT.	42	18" TRI. SP. TYP.
B3	JUNCUS EFFUSUS 'QUARTZ CREEK'/ QUARTZ CREEK RUSH	1 GAL. CONT.	14	24" TRI. SP. TYP.
	JUNCUS INFLEXUS 'BLUE ARROWS'/ BLUE ARROWS RUSH	1 GAL. CONT.	28	24" TRI. SP. TYP.
B4*	CAREX ELATA 'BOWLES GOLDEN'/ GOLDEN SEDGE	1 GAL. CONT.	28	24" TRI. SP. TYP.
	JUNCUS EFFUSUS 'QUARTZ CREEK'/ QUARTZ CREEK RUSH	1 GAL. CONT.	28	24" TRI. SP. TYP.

\* PLANT IN GROUPS OF 3-7 OF EACH SPECIES

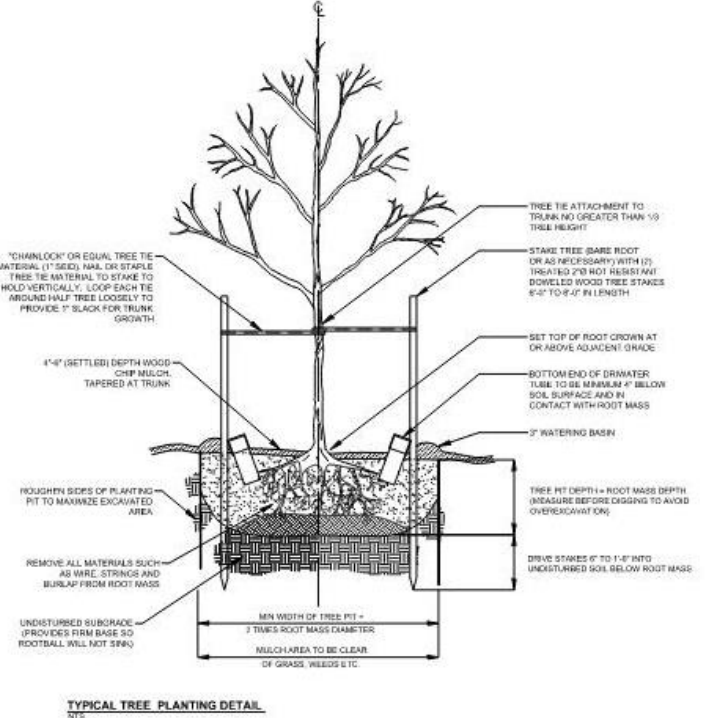
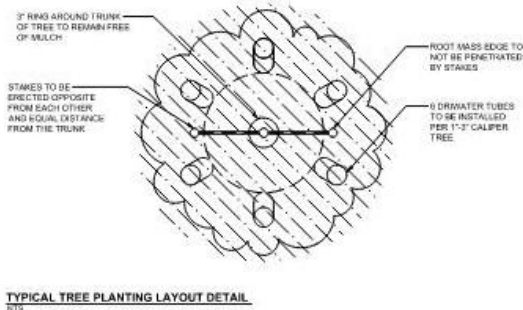
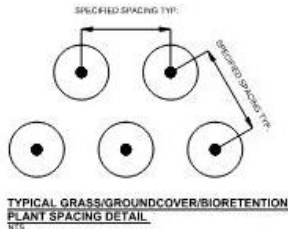

CALL 2 DAYS BEFORE YOU DIG  
1-800-424-5555



DATE	DATE	DATE
BY	BY	BY
DATE	DATE	DATE
DATE	DATE	DATE

CITY OF TACOMA  
ENVIRONMENTAL SERVICES DEPARTMENT  
615 SPRAGUE BIORETENTION RAIN GARDEN

LANDSCAPE SCHEDULE

REV. NO.
REV. NO.
REV. NO.
REV. NO.

## Appendix 3: Landscape Management Plan (LMP)

When required by TMC 13.06.090.B, a Landscape Management Plan (LMP) shall be submitted for developments that require Landscape Plans. Developments with less than 500 square feet of required landscape area are not required to submit an LMP. New Permanent Roadways that require less than 10 street trees do not require an LMP.

Landscape Management Plans shall address the following:

- Entity responsible for maintenance of the landscape during the establishment period, 3 full growing seasons (years) following planting;
- A schedule of maintenance activities, including, but not limited to, pruning, watering, fertilization, control of Noxious Weeds and Nuisance Plants and replacement of dead and/or damaged plant materials;
- irrigation option(s) selection and maintenance schedule; and,
- inventory of trees to be filled out upon project completion and updated during the establishment period.

NOTE: this form is not required to be submitted, however, it is meant a guide the development of a required Landscape Management Plan and help designate management activities to support plant survivability through the establishment period.

Before finalizing development plans, visit the Planning and Development Services (PDS) website at [www.tacomapermits.org](http://www.tacomapermits.org), contact the permit center at (253) 591-5030, or visit them at 747 Market Street on the third floor, to verify that all other applicable City codes and manuals have been met.

### Contents

- 1.0 Development Information
- 2.0 Landscaping Requirements and Standards (checklist)
- 3.0 Landscape Management Schedule
- 4.0 As-built Tree Inventory
- 5.0 Special Landscape Management Areas
- 6.0 Other Landscape Areas
- 7.0 Irrigation Option(s) Selection and Maintenance Schedule

## 1.0 DEVELOPMENT INFORMATION

Development Information		
<b>Date of Final Landscape Management Plan:</b>		
<b>Maintenance Entity Contact Information:</b>		
Company Name:	#:	Email:
Individual Name:	#:	Email:
<b>Site Information:</b>		
Site address:	Parcel No.:	
Name of project:	Permit number:	
Date of application:	Permit Issuance Date:	

## 2.0 LANDSCAPING REQUIREMENTS AND STANDARDS

The below landscaping requirements and standards checklist is intended to document which requirements and standards apply to this Landscape Management Plan, as defined by Tacoma Municipal Code 13.06.090B and the Urban Forest Manual. Check all of the applicable Landscape Requirements and Standards:

Landscaped Areas	
<input type="checkbox"/>	On-Site Tree Canopy Credits
<input type="checkbox"/>	On-Site Tree Retention
<input type="checkbox"/>	Street Trees
<input type="checkbox"/>	Overall Site Landscaping
<input type="checkbox"/>	Site Perimeter Landscaping
<input type="checkbox"/>	Parking Lot Landscaping
<input type="checkbox"/>	Landscaping Buffers
<input type="checkbox"/>	X District Front Yard and Foundation Landscaping

All landscape management tasks and activities shall be carried out in a manner to preserve the intended function(s) of the required landscaped area's intent as described in TMC 13.06.090B, and the Urban Forest Manual. Required landscaping must be continuously maintained in a healthy manner. Plants that die must be replaced one for one.

The intended functions of the required landscaping are as follows (check all that apply):

**On Site Tree Canopy:**

Trees are an integral part of our communities and the ecological systems in which they exist. They provide significant economic, social and ecological benefits, such as carbon sequestration, reduction of the urban heat island effect, energy savings, reduction of stormwater runoff, improvement of water quality, psychological healing and calming qualities and increased value of business and residential properties. Trees are as necessary as water, infrastructure, and energy to sustaining healthy communities and the health of the urban forest is directly linked to the health of the Puget Sound.

**On Site Tree Retention:**

Trees provide more services as they mature, helping to reduce urban heat island, manage stormwater, provide habitat, and improve air quality. If protected properly, trees retained through development offer more immediate benefits to the urban forest than newly transplanted trees. Therefore, tree retention is a priority, and in some zones tree retention is required to reflect this priority.

**Street Trees:**

Street trees are essential public infrastructure that provide multiple community benefits including improving aesthetics, calming traffic, providing habitat, shading and cooling to reduce urban heat, managing stormwater, and visual buffering and noise separation from streets. In addition to the requirements of the Zoning Code in TMC 13.06, street trees are regulated by TMC 9.20 Urban Forestry. When constructing in proximity to existing street trees, or proposing modifications such as pruning or removal of existing street trees, refer to TMC 9.20 for specific requirements.

**Overall Site:**

The general intent of the landscaping across the entire site is to contribute to the aesthetic environment of the City; to provide green spaces that can support wildlife, such as birds, in the urban environment; help reduce stormwater runoff; filter pollution; buffer visual impacts of development and contribute to the planting, maintenance, and preservation of a stable and sustainable urban forest.

All landscaped Areas must be maintained in a manner as to not degrade or negatively impact the landscape. Such negative impacts to the landscaping include, but are not limited to:

- excessive pruning of trees and shrubs such that it adversely affects the healthy living condition of the plant, significantly damages the natural growing form of the plant, or eliminates or significantly reduces the purpose for the planting;
- removal of required living plants;
- failure to replace dead plants one for one; and
- intentional planting of invasive species or noxious weeds as defined by the Pierce County Noxious Weed Control Board

**Site Perimeter:**

Site Perimeter Landscaping is intended to ensure that areas abutting property lines, not developed with structures, are attractive, and provide the environmental benefits of vegetation to enhance livability, improve community health, provide habitat, and help to soften the impacts of development.

**Parking Lot Landscaping:**

Parking lot landscaping is intended to provide visual relief, to enhance the aesthetic appearance, screen from adjacent sites and public areas, reduce environmental impacts of parking and other paved areas, and to provide shade and shelter for pedestrians.

**Landscaping Buffers:**

Landscaping buffers are intended to function as a substantial vegetative screen providing physical and visual separation between dissimilar districts to soften visual impacts. Landscape Buffers also provide the aesthetic and environmental benefits of vegetation including enhancing livability, improving community health, providing habitat, and helping soften the impacts of development.

**X District Front Yard and Foundation Landscaping:**

The intent of X District Front Yard and Foundation Landscaping is to grow a combination of shrubs and groundcover to soften the visual appearance of exposed foundations and building frontages in highly trafficked pedestrian areas.

### 3.0 LANDSCAPE MANAGEMENT SCHEDULE

In the table below, indicate the month and year the planned management activity will be carried out for all required landscaping. The year of the management activity is indicated by the number input into the cell, e.g. the number 2 is input into the cell if the management activity is to be carried out during year 2. Year 0 is the as-built year, and year 1 is the first growing season. In many cases, management activities will be carried out during multiple years, the cell should indicate all years when the management activity will be carried out.

Trees	Month											
Management Activity	J	F	M	A	M	J	J	A	S	O	N	D
<b>Pruning:</b>												
<b>Crown Raising (for clearance)</b> (suggested 3 <sup>rd</sup> year after planting)												
<b>Removal of dead/ diseased/ dying branches</b>												
<b>Structural Pruning</b>												
<b>Removal &amp; Replacement:</b>												
<b>dead/diseased/dying trees</b> (trees should be replaced between Oct. 1 and March 1)												
<b>Watering:</b>												
3 years of watering for establishment minimum, during dry season												

Shrubs & Groundcover	Month											
Management Activity	J	F	M	A	M	J	J	A	S	O	N	D
<b>Pruning:</b>												
<b>for public safety / visibility</b>												
<b>Removal of dead / diseased / dying branches</b>												
<b>Removal &amp; Replacement:</b>												
(should be replaced between Oct. 1 and March 1)												
<b>Watering:</b>												
3 years of watering for establishment minimum, during dry season												

Weed Control Frequency & Mode of Action				
<input type="checkbox"/> weekly	<input type="checkbox"/> biweekly	<input type="checkbox"/> monthly	<input type="checkbox"/> bimonthly	<input type="checkbox"/> other
<b>Mode of Action</b> (e.g. hand-weeding):				

Mulch	Month											
	J	F	M	A	M	J	J	A	S	O	N	D
<b>Spread Mulch (recommended 3-4" thick layer in planters, tree wells, and planting beds)</b>												

## 4.0 AS-BUILT TREE INVENTORY

In the table below, indicate a list of trees that were retained through development as well as a list of trees that were planted on site during development. This list is intended to be updated with any trees that do not become established and need to be replaced.

*As-built Tree Inventory	Quantity in good health			Quantity to Replace
	Year 1	Year 2	Year 3	
<b>Retained Trees, listed by Species:</b>				
<b>New trees planted:</b>				

\* During the Establishment Period, the As-built Tree Inventory shall be updated with the quantities of trees that have died and/or been damaged and need to be replaced.

## 5.0 SPECIAL LANDSCAPE MANAGEMENT AREAS

This special landscape management areas section outlines the landscape elements that require specialized management instructions not captured in the landscape management schedule.

These specialized management instructions include, but are not limited to:

- General site cleanup
- Plant species specific care practices (such as reduction of irrigation, pest management, fruit gleaning, etc.)
- Landscaped Area specific care practices (such as Buffers, Perimeters, etc.)

**Landscaping Element:**

**Specialized Management Instructions:**

## 6.0 OTHER MANAGEMENT AREAS

The special landscape areas section includes specific maintenance instructions for specialized landscape features including but not limited to:

- Pervious paving
- Stormwater management features (such as rain gardens, swales, etc.)
- Raised planting beds
- ROW plantings (other than trees)
- Mitigation for wetlands and/or shorelines

**Specialized Landscape Area:**

**Specialized Landscape Feature Instructions:**

## 6.0 IRRIGATION OPTION(S) SELECTION AND MAINTENANCE SCHEDULE

Select one or more of the irrigation options listed below for all landscaping. If more than one irrigation option is selected, the required Landscape Plan must clearly demarcate which landscaping is to be irrigated using which irrigation option.

- Option 1: A permanent built-in irrigation system with automatic controller designed to provide sufficient water to ensure that all required Landscaped Areas survive the Establishment Period. The system design shall be prepared by a Registered Landscape Architect, certified landscape professional, certified professional horticulturalist, or irrigation specialist.
  
- Option 2: A temporary irrigation system with automatic controller designed to provide sufficient water to ensure that all required Landscaped Areas survive the Establishment Period. The system design shall be prepared by a Registered Landscape Architect, certified landscape professional, certified professional horticulturalist, or irrigation specialist.
  
- Option 3: Irrigation by hand. If this option is chosen, an inspection may be required once a year during the establishment period after the final inspection to ensure that the landscaped area(s) has become established.

### Irrigation Maintenance Schedule (Options 1 and 2)

Management Activity	J.	F.	M.	A.	M.	J.	J.	A.	S.	O.	N.	D.
<b>Spring Startup:</b>												
open main valve												
test sprinkler heads												
set ET-based, seasonal, or weather-based manual or automatic programs												
<b>Winterization:</b>												
drain (blowout) pipes and sprinkler heads												
close valves and shut down automatic controllers												
<b>System Monitoring:</b>												
activate, monitor, and adjust irrigation settings and heads												

For all Irrigation Options, the following information is required. If irrigation information (frequency and duration) varies by Landscaped Area, indicate for all irrigation zones.

Irrigation: Duration (minutes) / Frequency				
Watering Season Start Date: _____		Watering Season End Date: _____		
<b>Zone 1: Duration: _____ minutes Frequency: (check below)</b>				
<input type="checkbox"/> More than once a day	<input type="checkbox"/> daily	<input type="checkbox"/> every other day	<input type="checkbox"/> 3 days a week	<input type="checkbox"/> weekly
<b>Zone 2: Duration: _____ minutes Frequency: (check below)</b>				
<input type="checkbox"/> More than once a day	<input type="checkbox"/> daily	<input type="checkbox"/> every other day	<input type="checkbox"/> 3 days a week	<input type="checkbox"/> weekly
<b>Zone 3: Duration: _____ minutes Frequency: (check below)</b>				
<input type="checkbox"/> More than once a day	<input type="checkbox"/> daily	<input type="checkbox"/> every other day	<input type="checkbox"/> 3 days a week	<input type="checkbox"/> weekly

Tree Irrigation: Volume / Frequency				
Watering Season Start Date: _____		Watering Season End Date: _____		
<b>Volume of Water per Application: _____ gallons Frequency: (check below)</b>				
<input type="checkbox"/> More than once a day	<input type="checkbox"/> daily	<input type="checkbox"/> every other day	<input type="checkbox"/> 3 days a week	<input type="checkbox"/> weekly

## Appendix 4: Sample Tree Protection Plan and Sample Arborist Report

**TO:** CITY OF TACOMA, PLANNING AND DEVELOPMENT SERVICES  
**FROM:** ARBORISTS NAME, COMPANY NAME  
**SUBJECT:** PROJECT NAME AND PERMIT NUMBER (IF APPLICABLE)  
TREE PRESERVATION ASSESSMENT AND PROTECTION PLAN

**DATE:**

### ASSIGNMENT AND SCOPE OF REPORT

This report is provided for Project Name and Permit Number, (Parcel #0000000000), for the portion of land Description of the Subject Area, wherein landscaping improvements are proposed to be constructed around existing trees. The Permit Applicant or Property Owner has elected to retain several trees through construction activities to comply with City of Tacoma Municipal Code 13.06.090B. This report satisfies the requirements of the City of Tacoma Urban Forest Manual (UFM) Chapter 7, Section 7.2 Tree Protection Plans and TMC 13.06.090B.

The scope of this report is to provide the following:

- A visual tree assessment for health and condition;
- An inventory of all trees within the site extent (as described above) over 1-inch in diameter, not including two dense patches of quaking Aspen (*Populus tremuloides*) as noted on the attached plan, which were measured by the extents of the canopy;
- Recommendations regarding which trees should be saved based on their health and proximity to construction activities; and
- Construction management recommendations for protection of trees identified to be saved, including specifications for the required tree protection fencing around the tree protection zones (TPZ).

The subject site is proposed to be improved with a new 8-foot sidewalk on the southern edge of the hillside on the entrance drive. In addition, a new bioretention facility will be constructed in the southwest corner where the two hillsides meet (see attached plan), as well as new proposed trees, shrubs and groundcovers around the existing vegetation on the hillside.

Draft development plans for the Cheney Phase 2 Improvements were reviewed (90%), and a "Preservation Value" for each tree was determined based on the trees' health, defects and potential impacts from construction activities. Each tree has been assigned an identification number and a preservation value (See inventory table) that correlates to the attached plan.

### TREE PROTECTION ZONE/FENCING

The TPZ is measured at 1-foot outwards from the tree trunk (radius) for every 1-inch of tree trunk diameter at breast height (DBH), and completely encircles the tree. For example, a tree with a twelve-inch DBH would have a TPZ of twelve-feet in radius from the tree trunk.

Tree protection fencing should be placed at the edge of the TPZ or at the edge of the drip-line (whichever is greater) before construction activities begin. When the TPZ or drip-line is interrupted by paved surfaces that will not be disturbed through construction, tree protection fencing may be installed at the edge of pavement. Tree protection fencing should also be installed at the boundary of any open space tracts or conservation easements that abut the construction site.

Tree protection fencing should be installed flush with the initial undisturbed grade, and should be a readily visible 6-foot high chain link, where feasible, or high-visibility fencing where topographic conditions do not allow for chain link. Fence posts should be installed using above ground pier blocks only.

## CONSTRUCTION MANAGEMENT

All fencing should remain in place until the Engineer authorizes removal or substantial completion is issued, whichever occurs first. Signs should be attached to the fencing stating that the area inside the fencing is a tree protection zone (TPZ), and that the area is not to be disturbed, unless prior approval has been obtained from the City, project Engineer and/or a Certified Arborist. Approved tree protection signs are attached.

The following construction activities shall not be performed within the tree protection zone:

- Dumping or storage of materials such as building supplies, soil, waste items, vehicles or equipment;
- Parking or maneuvering vehicles;
- Excavation for utility or building construction;
- Construction of new paved surfaces; and/or
- Changes to the grade.

Any landscaping done in the TPZ subsequent to the removal of the fencing shall be accomplished with light machinery or hand labor.

If fencing needs to be moved closer to a tree or group of trees for construction ease, contact a Certified Arborist for additional assessment specific to the tree(s) in question.

ID #	Scientific Name	Common Name	DBH, Height, Width	*Preservation Value	Recommendation	TPZ dia.	Flow Control Credit
1	<i>Alnus rubra</i>	red alder	21.25", 40', 30'	Low	Remove	NA	NA
2	<i>Fraxinus latifolia</i>	Oregon ash	21.25", 60', 50'	High	Save	50'	196
3	**MS <i>Fraxinus latifolia</i>	Oregon ash	(6)2.25", 12', 12'	Moderate	Save	12'	98
4	**MS <i>Fraxinus latifolia</i>	Oregon ash	(6)1.75", 12', 15'	Moderate	Save	12'	98
5	<i>Fraxinus latifolia</i>	Oregon ash	10", 40', 35'	High	Save	35'	196
6	<i>Fraxinus latifolia</i>	Oregon ash	3", 25', 15'	Moderate	Save	15'	98
7	**MS <i>Salix schouleriana</i>	Schouler's willow	(10)2.25", 20', 20'	Moderate/Low	Thin, clearance prune (16'HT)	20'	NA
8	<i>Fraxinus latifolia</i>	Oregon ash	2.75", 20', 17'	High	Save	17'	98
9	<i>Malus sp.</i>	crabapple	4", 16', 20'	Low	Remove	NA	NA
10	**MS <i>Fraxinus latifolia</i>	Oregon ash	(6)2", 25', 20'	Moderate	Thin, clearance prune (16'HT)	20'	98
11	**MS <i>Malus sp.</i>	crabapple	(2)3.5", 25', 16'	Moderate/Low	Remove	NA	NA
12	**MS <i>Fraxinus latifolia</i>	Oregon ash	(3)2.25", 25', 16'	Moderate	Save	16'	98
13	<i>Malus sp.</i>	crabapple	3.5", 20', 20'	Low	Remove	NA	NA
14	<i>Malus sp.</i>	crabapple	3", 16', 16'	Low	Remove	NA	NA
15	<i>Malus sp.</i>	crabapple	3-4", 12-20', 12-20'	Moderate/Low	Save	20'	6
16	<i>Malus sp.</i>	crabapple	3-4", 12-20', 12-20'	Moderate/Low	Save	20'	6

ID #	Scientific Name	Common Name	DBH, Height, Width	*Preservation Value	Recommendation	TPZ dia.	Flow Control Credit
------	-----------------	-------------	--------------------	---------------------	----------------	----------	---------------------

17	Fraxinus latifolia	Oregon ash	5", 25', 20'	High	Save	20'	98
18	Malus sp.	crabapple	3-4", 12-20', 12-20'	Moderate/Low	Save	20'	6
19	Malus sp.	crabapple	3-4", 12-20', 12-20'	Moderate/Low	Save	20'	6
20	Malus sp.	crabapple	3-4", 12-20', 12-20'	Moderate/Low	Save	20'	6
21	Malus sp.	crabapple	3-4", 12-20', 12-20'	Moderate/Low	Save	20'	6
22	Pseudotsuga menziesii	Douglas fir	12", 60', 25'	High	Save	25'	63
23	Fraxinus latifolia	Oregon ash	21.5", 50', 40'	High	Save	43'	98
24	Malus sp.	crabapple	3-4", 12-20', 12-20'	Moderate/Low	Save	20'	6
25	Malus sp.	crabapple	3-4", 12-20', 12-20'	Moderate/Low	Save	20'	6
26	Malus sp.	crabapple	3-4", 12-20', 12-20'	Low	Remove	NA	NA
27	Malus sp.	crabapple	3-4", 12-20', 12-20'	Low	Remove	NA	NA
28	Malus sp.	crabapple	3-4", 12-20', 12-20'	Low	Remove	NA	NA
29	Pseudotsuga menziesii	Douglas fir	5", 25', 20'	High	Save	20'	47
30	Malus sp.	crabapple	3-4", 12-20', 12-20'	Low	Remove	NA	NA
31	Malus sp.	crabapple	3-4", 12-20', 12-20'	Low	Remove	NA	NA
32	**MS Arbutus menziesii	Pacific madrone	(2)19.75", 60', 60'	High	Save	60'	192
33	Pseudotsuga menziesii	Douglas fir	22.25", 70', 50'	High	Save	50'	63
34	Pseudotsuga menziesii	Douglas fir	22.25", 60', 50'	High	Save	50'	63
35	Malus sp.	crabapple	3-4", 12-20', 12-20'	Low	Remove	NA	NA
36	Arbutus menziesii	Pacific madrone	20", 35', 25'	High	Save	25'	192

\*Note, "Preservation Value" is a direct correlation to tree health/condition and does not take into account cultural relevancy or ecological implications of the tree, which can otherwise add value.

\*\*MS, Multi-Stemmed. Trees are listed by average stem diameter preceded with the number of stems in parenthesis; width and TPZ is determined by edge of drip-line of the group of trees.

Total Retained Trees	25
----------------------	----

## **CONCLUSIONS**

The recommendations in this report reflect the current development proposal. Any changes made regarding the location, size, or extent of impact of the construction of the proposed landscaping, infrastructure, or utilities will require further assessment to meet the requirements of the City of Tacoma City of Tacoma Urban Forest Manual (UFM) Chapter 7, Section 7.2 Tree Protection Plans and TMC 13.06.090B.

The recommendations in this report are based on the current conditions of the existing trees dated \_\_\_\_\_, and their current associated preservation values. Should the conditions and/or health of the trees decline prior to construction activities, an additional assessment may be needed. To the best of my knowledge and belief, the statements and opinions here are correct, subject to any limiting conditions set forth. This report satisfies the City of Tacoma's Certified Arborists Report requirements per the City of Tacoma Urban Forest Manual (UFM) Chapter 7, Section 7.2 Tree Protection Plans and TMC 13.06.090B and should therefore prove eligibility of Tree Retention Credit therein.

Sincerely,

## **Arborist Signature**

Arborist Name, Title and Company Name

ISA Certified Arborist Number PN-1234A

Email

Telephone Number

Mailing Address

## Appendix 5: Tree Protection Zone Sign – General

# PROTECT TREE

**This tree is to be retained and protected  
from construction impacts**

## DO:

- Contact City of Tacoma representative before commencement of work within the Tree Protection Zone
- Provide tree protection fencing at the edge of Tree Protection Zone
- Protect roots (retain existing pavement/mulch non-paved surfaces)

## DO NOT:

- Remove or prune tree
- Excavate, trench, operate equipment or stack materials within the Tree Protection Zone

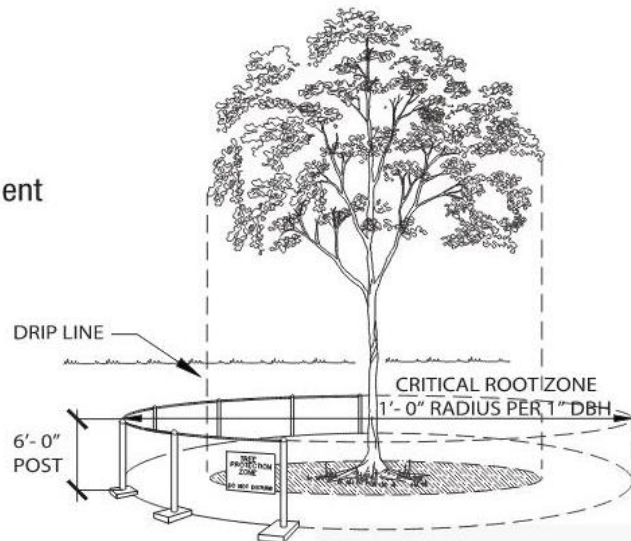

TREE PROTECTION ZONE IS AT THE EDGE OF THE CRITICAL ROOT ZONE OR DRIP LINE, WHICHEVER IS GREATER

For more information about this project, please call \_\_\_\_\_



## Appendix 6: Tree Protection Zone Sign – For Trees in Paved Areas

# PROTECT TREE

**This tree is to be retained and protected  
from construction impacts**

### DO:

- Contact City of Tacoma representative before commencement of work within the Drip Line
- Provide tree protection fencing at the edge of tree pit or planting strip
- Protect roots (retain existing pavement/mulch non-paved surfaces)

### DO NOT:

- Remove or prune tree
- Excavate or trench within Drip Line
- Operate equipment/stack materials within the Drip Line

4'-6" TO 6'-0" HIGH CHAIN LINK OR TEMPORARY TREE AND LANDSCAPE PROTECTION (HIGH VISIBILITY) FENCING TO ENCLOSE ENTIRE TREE PIT

PAVED SURFACE MAINTAINED TO PROTECT EXTENDED ROOTS OUTSIDE FENCE

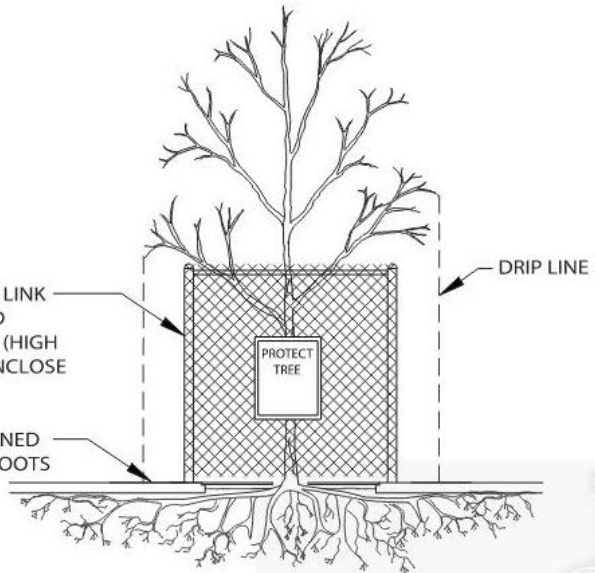

For more information about this project, please call \_\_\_\_\_



## Appendix 7: Tree Lists



## Preapproved Large Trees

City of Tacoma  
Urban Forest Manual  
cityoftacoma.org/ufm

Large (per TMC 13.06.090B)







































Tree Genus	Tree Species and Cultivar or Variety	Tree Common Name	Select Cultivars (height, width, growth rate and canopy factor do not reflect all Select Cultivars. Please research cultivars to ensure they are still appropriate)	Anticipated Mature Height (in feet)	Anticipated Mature Width (in feet)	Growth Rate (Fast 3, Medium 2 or Slow 1)	Canopy Factor (see TMC 13.06.502)	Minimum Planting Strip Width Recommended	West Coast Native	Form	Special Characteristics Overhead Utility friendly: N/A Ornamental: N/A Evergreen: Deciduous:
<i>Aesculus</i>	<i>hippocastanum</i>	horse chestnut		75	40	3	90	8			
<i>Cedrus</i>	<i>deodara</i>	deodar cedar		60	40	3	72	6			
<i>Fagus</i>	<i>sylvatica</i>	European beech	Riversii	60	45	3	81	8			
<i>Liriodendron</i>	<i>tulipifera</i>	tulip tree		80	30	3	72	8			
<i>Metasequoia</i>	<i>glyptostrobooides</i>	dawn redwood		80	30	3	72	10			
<i>Platanus</i>	<i>x acerifolia</i>	London planetree	Bloodgood,' Exclamation!™, Yarwood, 'Morton Euclid'	70	40	3	84	8			
<i>Platanus</i>	<i>occidentalis</i>	American sycamore		75	75	3	168.75	12			
<i>Platanus</i>	<i>orientalis</i>	Oriental planetree		70	70	3	147	12			
<i>Pseudotsuga</i>	<i>menziesii</i>	Douglas-fir*		90	30	3	81	12	✓		
<i>Quercus</i>	<i>ilex</i>	holm oak		50	50	3	75	6			
<i>Quercus</i>	<i>kelloggii</i>	California black oak		60	45	3	81	6	✓		
<i>Quercus</i>	<i>rubra</i>	red oak		60	45	3	81	6			
<i>Sequoia</i>	<i>sempervirens</i>	coastal redwood*		100	25	3	75	12	✓		
<i>Sequoiadendron</i>	<i>giganteum</i>	Giant Sequoia		80	50	3	120	12	✓		
<i>Thuja</i>	<i>plicata</i>	Western red-cedar		80	30	3	72	12			
<i>Ulmus</i>	<i>americana</i>	American elm	Jefferson, New Harmony, Valley Forge	70	65	3	136.5	10			
<i>Ulmus</i>	<i>davidiana</i>	Accolade® Elm	Morton	70	60	2	84	10			



**Preapproved Medium Trees**

City of Tacoma  
Urban Forest Manual  
cityoftacoma.org/ufm

Medium (per TMC 13.06.090B)

Tree Genus	Tree Species and Cultivar or Variety	Tree Common Name	Select Cultivars (height, width, growth rate and canopy factor do not reflect all Select Cultivars, Please research cultivars to ensure they are still appropriate)	Anticipated Mature Height (in feet)	Anticipated Mature Width (in feet)	Growth Rate (Fast 3, Medium 2 or Slow 1)	Canopy Factor (see TMC 13.06.502)	Minimum Planting Strip Width Recommended	West Coast Native	Form	Special Characteristics Overhead Utility friendly: N/A Ornamental: Evergreen: Deciduous:
Picea	orientalis	oriental spruce	Aureospicata	60	30	3	54	6			
Pinus	flexilis	Vanderwolf's pyramid pine	Vanderwolf's Pyramid	50	30	3	45	6			
Pinus	ponderosa	ponderosa pine*		80	20	3	48	12			
Quercus	bicolor	swamp white oak		45	45	3	60.75	6			
Quercus	canbyi	Sierra red oak or Canby Oak		45	40	3	54	6			
Quercus	chrysolepis	canyon live oak		55	30	3	49.5	6			
Quercus	coccinea	scarlet oak		50	40	3	60	6			
Quercus	frainetto	Italian oak		50	30	3	45	8			
Quercus	garryana	Oregon white oak		65	45	2	58.5	6			
Quercus	imbricaria	shingle oak		50	40	2	40	6			
Quercus	macrocarpa	Cobblestone® Oak	JFS-KW14	55	45	2	49.5	6			
Quercus	muehlenbergii	chinquapine oak		45	45	3	60.75	6			
Quercus	phellos	willow oak		50	35	3	52.5	6			
Sophora	japonica	Japanese pagoda tree	Millstone, Regent	45	35	2	31.5	6			
Tillia	tomentosa	silver linden	Sterling Silver, Satin Shadow	45	35	3	47.25	6			
Ulmus	caprinifolia x parvifloia	frontier elm		45	30	3	40.5	6			
Ulmus	parviflora	emerald vase elm	Emer II Alee	50	35	3	52.5	6			
Zelkova	serrata	Japanese zelkova	Green Vase, Halka	45	30	3	40.5	6			
Zelkova	serrata	Japanese zelkova	Village Green	40	40	3	48	6			



## Preapproved Small Trees

City of Tacoma  
Urban Forest Manual  
cityoftacoma.org/ufm

Small (per TMC 13.06.090B)































































Tree Genus	Tree Species and Cultivar or Variety	Tree Common Name	Select Cultivars (height, width, growth rate and canopy factor do not reflect all Select Cultivars, Please research cultivars to ensure they are still appropriate)	Anticipated Mature Height (in feet)	Anticipated Mature Width (in feet)	Growth Rate (Fast 3, Medium 2 or Slow 1)	Canopy Factor (see TMC 13.06.502)	Minimum Planting Strip Width Recommended	West Coast Native	Form	Special Characteristics Overhead Utility friendly: Ornamental: Evergreen: Deciduous:
<i>Acer</i>	<i>circinatum</i>	vine maple	Pacific Fire	12	8	2	1.92	4	✓		
<i>Acer</i>	<i>ginnala</i>	amur maple	Flame	20	20	2	8	4			
<i>Acer</i>	<i>griseum</i>	paperbark maple		25	20	1	5	4			
<i>Amelanchier</i>	<i>alnifolia</i>	standing ovation serviceberry	Obelisk	15	7	2	2.1	4	✓		
<i>Amelanchier</i>	<i>x grandiflora</i>	apple serviceberry	Autumn Brilliance, Cole's Select, Ballerina, Princess Diana	20	15	2	6	4	✓		
<i>Amelanchier</i>	<i>laevis</i>	snowcloud serviceberry	Spring Flurry, Snowcloud	28	20	2	11.2	4	✓		
<i>Arbutus</i>	<i>unedo</i>	strawberry tree		20	20	1	4	4			
<i>Betula</i>	<i>papyrifera</i>	paper birch		50	35	2	35	8	✓		
<i>Betula</i>	<i>utilis</i> var. <i>jaquemontii</i>	jacquemonti birch		40	30	3	36	6			
<i>Callitropsis</i>	<i>nootkatensis</i>	Alaska yellow cedar		50	25	3	37.5	6	✓		
<i>Carpinus</i>	<i>betulus</i>	European hornbeam		40	25	2	20	6			
<i>Carpinus</i>	<i>caroliniana</i>	American hornbeam		25	20	1	5	4			
<i>Cercidiphyllum</i>	<i>japonicum</i>	katsura tree		40	40	2	32	6			
<i>Cercidiphyllum</i>	<i>japonicum</i>	katsura tree	Red Fox	20	15	2	6	6			
<i>Cercis</i>	<i>canadensis</i>	Eastern redbud		25	30	2	15	4			
<i>Chamaecyparis</i>	<i>obstusa</i>	hinoki cypress	Gracilis	15	10	1	1.5	4			
<i>Chamaecyparis</i>	<i>pisifera</i>	sawara cypress		45	25	2	22.5	4			
<i>Chionanthus</i>	<i>retusus</i>	Chinese fringe tree		20	20	1	4	4			
<i>Cornus</i>	<i>controversa</i>	June snow dogwood	June Snow-JFS	30	40	3	36	6			
<i>Cornus</i>	<i>kousa</i>	kousa dogwood	Heart Throb (Pink), Milky Way, Satomi (Pink)	20	20	1	4	4			



## Preapproved Small Trees

City of Tacoma  
Urban Forest Manual  
cityoftacoma.org/ufm

Small (per TMC 13.06.090B)



























































Tree Genus	Tree Species and Cultivar or Variety	Tree Common Name	Select Cultivars (height, width, growth rate and canopy factor do not reflect all Select Cultivars, Please research cultivars to ensure they are still appropriate)	Anticipated Mature Height (in feet)	Anticipated Mature Width (in feet)	Growth Rate (Fast 3, Medium 2 or Slow 1)	Canopy Factor (see TMC 13.06.502)	Minimum Planting Strip Width Recommended	West Coast Native	Form	Special Characteristics Overhead Utility friendly:  Ornamental:  Evergreen:  Deciduous: 
<i>Cornus</i>	<i>kousa x nuttallii</i>	starlight dogwood	Starlight	30	20	3	18	4	✓		 
<i>Cornus</i>	<i>mas</i>	Cornelian cherry		18	22	2	7.92	6			  
<i>Cotinus</i>	<i>coggygria</i>	smoke tree		20	10	2	4	4			  
<i>Crataegus</i>	<i>crus-galli</i> var. <i>inermis</i>	thornless cockspur hawthorn		25	25	2	12.5	6			  
<i>Crataegus</i>	<i>x lavallei</i>	lavalle hawthorn		28	20	2	11.2	4			  
<i>Crataegus</i>	<i>viridis</i>	winter king hawthorn	Winter King	20	25	3	15	6			  
<i>Cryptomeria</i>	<i>japonica</i>	black dragon Japanese cedar	Black Dragon	15	10	1	1.5	4			 
<i>Cryptomeria</i>	<i>japonica</i>	Japanese cedar	Elegans Aurea, Sekkan Sugi	30	10	2	6	6			
<i>Cryptomeria</i>	<i>japonica</i>	Japanese cedar	Yoshino	40	20	3	24	6			
<i>Cupressus</i>	<i>arizonica</i> var. <i>glabra</i>	smooth cypress	Blue ice	20	8	3	4.8	6			
<i>Eucalyptus</i>	<i>neglecta</i>	omeo gum		20	15	3	9	4			
<i>Eucalyptus</i>	<i>parvula</i>	small-leaved gum		40	15	3	18	4			
<i>Fagus</i>	<i>sylvatica</i>	fastigiata beech	Dawyk Purple, Dawyk Gold	40	12	2	9.6	4			
<i>Frangula</i>	<i>purshiana</i>	cascara		30	25	3	22.5	4	✓		
<i>Franklinia</i>	<i>alatomaha</i>	franklin tree		18	12	2	4.32	4			  
<i>Ginkgo</i>	<i>biloba</i>	maidenhair tree	Princeton Sentry	40	15	3	18	4			
<i>Gleditsia</i>	<i>triacanthos</i>	Honey locust		45	35	2	31.5	4			
<i>Halesia</i>	<i>tetraptera</i>	Carolina silverbell		35	30	2	21	4			 
<i>Koelreuteria</i>	<i>paniculata</i>	golden rain tree		30	30	2	18	4			  
<i>Laburnum</i>	<i>x watereri</i>	golden chain tree	Vossi	25	20	2	10	4			  



## Preapproved Small Trees

City of Tacoma  
Urban Forest Manual  
cityoftacoma.org/ufm

Small (per TMC 13.06.090B)























































Tree Genus	Tree Species and Cultivar or Variety	Tree Common Name	Select Cultivars (height, width, growth rate and canopy factor do not reflect all Select Cultivars, Please research cultivars to ensure they are still appropriate)	Anticipated Mature Height (in feet)	Anticipated Mature Width (in feet)	Growth Rate (Fast 3, Medium 2 or Slow 1)	Canopy Factor (see TMC 13.06.502)	Minimum Planting Strip Width Recommended	West Coast Native	Form	Special Characteristics Overhead Utility friendly:  Ornamental:  Evergreen:  Deciduous: 
<i>Lagerstroemia</i>	<i>indica</i>	crape myrtle	Muskogee, Natchez	20	20	3	12	2			  
<i>Lagerstroemia</i>	<i>indica</i>	crape myrtle	Zuni	15	10	3	4.5	2			  
<i>Maackia</i>	<i>amurensis</i>	amur maackia		25	20	2	10	4			 
<i>Magnolia</i>	<i>acuminata x denudata</i>	butterflies magnolia	Butterflies	20	20	2	8	4			  
<i>Magnolia</i>	<i>liliiflora 'Nigra' x sprengeri 'Diva'</i>	Galaxy Magnolia		40	25	2	20	4			 
<i>Magnolia</i>	<i>kobus</i>	kobus magnolia		25	15	1	3.75	4			  
<i>Magnolia</i>	<i>x soulangeana</i>	saucer magnolia		30	30	2	18	6			 
<i>Magnolia</i>	<i>stellata</i>	star magnolia		20	15	1	3	6			  
<i>Malus</i>	<i>crabapple sp.</i>	crabapple	Purple Prince, Golden Raindrops, Sentinel, Snowdrift, Royal Raindrops	20	15	2	6	4			 
<i>Malus</i>	<i>tschonoskii</i>	Tschonoski crabapple		30	15	2	9	4			 
<i>Nyssa</i>	<i>sylvatica</i>	tupelo	Green Gable, Wildfire	40	25	3	30	4			
<i>Nyssa</i>	<i>sylvatica</i>	tupelo	Red Rage, David Odom	35	20	3	21	4			
<i>Ostrya</i>	<i>virginiana</i>	American hophornbeam		40	25	3	30	4			
<i>Oxydendrum</i>	<i>arboreum</i>	sourwood		20	15	1	3	4			 
<i>Parrotia</i>	<i>persica</i>	Persian ironwood	Vanessa and Ruby Vase	30	15	2	9	4			
<i>Picea</i>	<i>abies</i>	Norway spruce		60	30	2	36	6			
<i>Picea</i>	<i>omorika</i>	Serbian spruce	Bruns, Berliner's Weeper	30	15	2	9	6			
<i>Picea</i>	<i>orientalis</i>	oriental spruce	Skylands	35	12	2	8.4	6			
<i>Pinus</i>	<i>contorta var. contorta</i>	shore pine		45	30	2	27	8	✓		
<i>Quercus</i>	<i>macrocarpa</i>	Urban Pinnacle® Oak	JFS-KW3	55	25	2	27.5	6			



# Preapproved Small Trees

City of Tacoma  
Urban Forest Manual  
cityoftacoma.org/ufm

Small (per TMC 13.06.090B)

Tree Genus	Tree Species and Cultivar or Variety	Tree Common Name	Select Cultivars (height, width, growth rate and canopy factor do not reflect all Select Cultivars, Please research cultivars to ensure they are still appropriate)	Anticipated Mature Height (in feet)	Anticipated Mature Width (in feet)	Growth Rate (Fast 3, Medium 2 or Slow 1)	Canopy Factor (see TMC 13.06.502)	Minimum Planting Strip Width Recommended	West Coast Native	Form	Special Characteristics Overhead Utility friendly:  Ornamental:  Evergreen:  Deciduous: 
<i>Quercus</i>	<i>myrsinifolia</i>	bamboo leaf oak		35	25	3	26.25	4			
<i>Sciadopitys</i>	<i>verticillata</i>	Japanese umbrella pine		30	10	1	3	6			 
<i>Stewartia</i>	<i>pseudocamellia</i>	Japanese stewartia		30	20	2	12	4			  
<i>Styrax</i>	<i>japonicus</i>	Japanese snowbell	Pink Chimes	15	15	1	2.25	4			  
<i>Styrax</i>	<i>japonicus</i>	Japanese snowbell	Snowcone	25	20	2	10	4			  
<i>Styrax</i>	<i>obassia</i>	fragrant snowbell		25	20	2	10	4			  
<i>Syringa</i>	<i>pekinensis</i>	'Morton'	China Snow® Tree Lilac	20	20	2	8	4			  
<i>Syringa</i>	<i>pekinensis</i>	DTR 124'	Summer Charm® Pekin Lilac	25	15	2	7.5	4			  
<i>Syringa</i>	<i>reticulata</i>	Japanese tree lilac	Ivory Silk	20	15	2	6	4			  
<i>Thuja</i>	<i>plicata</i>	Arovirens cedar	Arovirens	50	20	3	30	8			
<i>Thuja</i>	<i>plicata</i>	Excelsa cedar	Excelsa	50	15	3	22.5	8			
<i>Trochodendron</i>	<i>aralioides</i>	wheel tree		25	15	1	3.75	4			 
<i>Tsuga</i>	<i>diversifolia</i>	Northern Japanese hemlock		40	20	3	24	6			
<i>Tsuga</i>	<i>mertensiana</i>	mountain hemlock		20	8	1	1.6	4	✓		 
<i>Zelkova</i>	<i>serrata</i>	City Sprite® Japanese Zelkova	JFS-KW1	25	20	2	10	6			 
<i>Zelkova</i>	<i>serrata</i>	Wireless® Japanese Zelkova	Schmidtlow	25	30	1	7.5	6			 



## NOT RECOMMENDED TREES

City of Tacoma  
Urban Forest Manual  
cityoftacoma.org/ufm

Tree Genus	Tree Species and Cultivar or Variety	Tree Common Name	Select Cultivars (height, width, growth rate and canopy factor do not reflect Select Cultivars. Please research cultivars to ensure they are still appropriate)	Anticipated Mature Height (in feet)	Anticipated Mature Width (in feet)	Growth Rate (Fast 3, Medium 2 or Slow 1)	Canopy Factor (see TMC 13.06.502)	Minimum Planting Strip Width Recommended	West Coast Native	Form	Justification
<b>THE FOLLOWING TREES ARE NOT RECOMMENDED</b>											
<i>Acer</i>	<i>Sp.</i>	Non - native maple species		28	28	3	23.52	4			Diversity
<i>Fraxinus</i>	<i>Sp.</i>	Ash species		20	18	1	3.6	4			Insect/Disease
<i>Liquidambar</i>	<i>styraciflua</i>	American sweetgum		50	30	3	45	10			Aggressive root system
<i>Prunus</i>	<i>laurocerasus/ lusitanica</i>	Cherry/ Portugese Laurel		20	15	2	6	4			Invasive species
<i>Prunus</i>	<i>Sp.</i>	Cherry Species		20	15	2	6	4			Diversity and Aggressive root system
<i>Pyrus</i>	<i>calleryana</i>	Ornamental Pear		20	15	2	6	8			Diversity and Aggressive root system
<b>THE FOLLOWING TREES ARE PROHIBITED</b>											
<i>Acer</i>	<i>campestre</i>	hedge maple		28	28	2	15.68	8			Invasive species
<i>Acer</i>	<i>platanoides</i>	Norway maple		50	40	3	60	10			Invasive species
<i>Ailanthus</i>	<i>altissima</i>	tree of heaven		40	30	3	36	8			Invasive species
<i>Eleagnus</i>	<i>angustifolia</i>	Russian olive		20	20	2	8	4			Invasive species
<i>Ilex</i>	<i>aquifolium</i>	English holly		40	15	2	12	6			Ivasive species
<i>Populus</i>	<i>sp.</i>	poplar/ cottonwood*		100	25	3	75	12	✓		Aggressive root system/ Weak wood
<i>Robinia</i>	<i>pseudoacacia</i>	black locust		40	25	3	30	6			Invasive species
<i>Salix</i>	<i>Sp.</i>	willow trees*		30	35	3	31.5	12			Aggressive root systems
<i>Sorbus</i>	<i>acuparia</i>	European mountain ash*		30	20	1	6	4			Invasive species
N/A	N/A	fruit trees (except ornamental types)*		N/A	N/A	N/A	N/A	N/A			Trip and fall hazard
N/A	N/A	nut trees*		N/A	N/A	N/A	N/A	N/A			Trip and fall hazard

\*Trees prohibited in the right-of-way per TMC 9.19.030

## Appendix 8: Urban Residential Landscaping Requirements Summary

	Urban Residential 1 (UR-1)	Urban Residential 2 (UR-2)	Urban Residential 3 (UR-3)
<b>Tree Retention</b> See <a href="#">Section 2.3</a> of this manual or TMC 13.06.090.B.3.e.(3).(b)	Regulated for all trees 6” DBH or greater		
<b>Tree Canopy Credits, minimum</b> See <a href="#">Section 2.2</a> of this manual or TMC 13.06.020F.1	30%	25%	20%
<b>Tree Canopy Credits, minimum with Bonus*</b> See <a href="#">Section 2.2</a> of this manual or TMC 13.06.020F.1 and 13.06.020.F.2	Bonus 1: 25% Bonus 2: 20%	Bonus 1: 20% Bonus 2: 15%	Bonus 1: 15% Bonus 2: 10%
<b>Street Trees</b> See <a href="#">Section 2.4</a> of this manual or TMC 13.06.090.B.4.f.(3)	Four small trees <b>or</b> three medium trees <b>or</b> two large trees required for every 100 linear feet of site frontage		
<b>Overall Site Landscaping</b> See <a href="#">Section 2.5</a> of this manual or TMC 13.06.090.4.d	5% of total site area not covered by structures		
<b>Parking Lot Landscaping</b> See <a href="#">Section 2.7</a> of this manual or TMC 13.06.090.4.g.(3)	Required between parking lots and streets.  Overall minimums: One Small Tree per 700 square feet; one Medium Tree per 1,000 square feet; or, one Large Tree per 1,400 square feet of parking lot area, including drive lanes.		
<b>Site Perimeter Landscaping</b>	Not required in UR zones		
<b>Landscaping Buffers</b>	Not required in UR zones		

## 1. Calculate required on-site tree credits

= [Lot area] x [% tree canopy credits per TMC 13.06.020]

Ex: [6,000 sf lot] x [.20 in UR-3] = 1,800 tree credits required

See UFM Chapter 3: Credits and Flexibility for exceptions.

## 2. Are there existing trees on site?

See TMC 13.06.020.F.3 for flexibility on development standards for tree retention.

### A Existing trees will be retained

Tree credits per inch DBH (diameter at breast height) for retained on-site trees per TMC 13.06.090.B.3.e(2)(b):

- Trees < 6" DBH = 50
- Trees 6" ≤ 12" DBH = 75
- Trees 12" ≤ 24" DBH = 100
- Trees > 24" DBH = 125

### B Existing trees will be removed

See Step 4 and reference TMC 13.06.090.B.3.e(3)(e) to calculate Canopy Loss Fee, if applicable

Note: Existing trees that are 24" DBH or larger shall not be removed unless preserving the tree(s) would significantly limit the reasonable development of the site per TMC 13.06.090.B.3.e(3)(f).

## 3. Are Tree Credit requirements met?

### A Yes

No Tree Credit fee is assessed

Ex: One Retained 8" tree = 75 credits/in = 600 credits  
Two Medium trees, and three Small trees planted = (2)\*(500)+(3)\*(200) = 1,400  
Total tree credits provided = 2,000  
2,000 > 1,800 tree credits required.

[Minimum tree credits from 1. above]  
**are less than or equal to**  
[Credits from retained trees] +  
[Credits from new trees]<sup>1,2</sup>

### B No

A Tree Credit Fee is assessed, equal to (tree credit deficit)\*(\$/tree credit listed in the UFM<sup>3</sup> Section 3.2

[Minimum tree credits from 1. above]  
**are greater than**  
[Credits from retained trees] +  
[Credits from new trees]

<sup>1</sup> Tree Credits for new trees are allocated per TMC 13.06.090.B.3.e(2)(c): Small = 200, Medium = 500, Large = 1,000

<sup>2</sup> Tree Credits provided in the right-of-way above those required can count toward on-site tree credit requirements per TMC 13.06.090.B.3.e(2)(d).

<sup>3</sup> For a canopy loss fee waiver for the removal of regulated trees down to the required on-site minimum tree credits, only trees 6" DBH or greater may count toward achieving the required tree credits.



## 4. Is Canopy lost that requires replacement?

### A Tree(s) under 6" DBH will be removed

Trees under 6" are not regulated.

### B Tree(s) 6"-18" DBH will be removed

For trees of this size, only those removed below the site's applicable Tree Credit requirement are considered when calculating Canopy Loss Fee. Replacement caliper inches planted are subtracted from Canopy Loss (inches) when calculating the fee.

Canopy Loss Fee = [(DBH inches of removed trees below minimum Tree Credits) - (Caliper inches of planted trees)] X [\$ per inch listed in UFM3 Section 3.2]

Ex: On a site where 1,800 tree credits are required, two 11" trees are removed and one (3" cal) medium tree is planted.

500 credits are provided. This does not meet minimum credits. Each 11" tree is equivalent to 825 credits, at 75 credits per inch. 18" x 75 credits per inch (= 1,350) would be required to meet minimum Tree Credits, so Canopy Loss Fee = [(18" Canopy Loss) - (3" Planted)] X [\$ per inch listed in UFM3 Section 3.2]

### C Tree(s) 18" DBH or larger will be removed

For trees 18" DBH or larger, the Canopy Loss Fee is determined by a cost-per-inch of DBH removed:

Canopy Loss Fee = [Canopy loss inches] X [\$ per inch listed in UFM3 Section 3.2]

## 5. Calculate required street trees

= Four Small Trees; Three Medium Trees; or Two Large Trees per 100 linear feet of site frontage  
TMC 13.06.090.B.4.f. and UFM<sup>4</sup> Section 2.4.

Ex: 50' linear frontage = 2 small trees or 2 Medium trees or 1 Large tree

## 6. Are additional street trees provided that count toward on-site Tree Credits?

When Street trees are planted above those required in Step 5, they can be counted toward on-site Tree Credits as described in UFM Section 8.2.8. and 8.2.9.

Ex: Total Site Frontage: 60 linear feet (If)  
3 medium trees planted = (3 trees) x (33.3 linear feet per tree) = 100 If planted  
100 If planted - 60 If required = 40 If additional provided  
= (1) medium tree = 500 Tree Credits that can be applied to on-site requirements.

<sup>4</sup> UFM refers to the City of Tacoma Urban Forest Manual: A compilation of City urban forestry practices and standards created to facilitate the planning, design, installation, and maintenance of trees and landscaping.

# Appendix 9: Urban Residential Tree Case Study

## 1. Existing Condition: 6,000 SF LOT IN UR-3

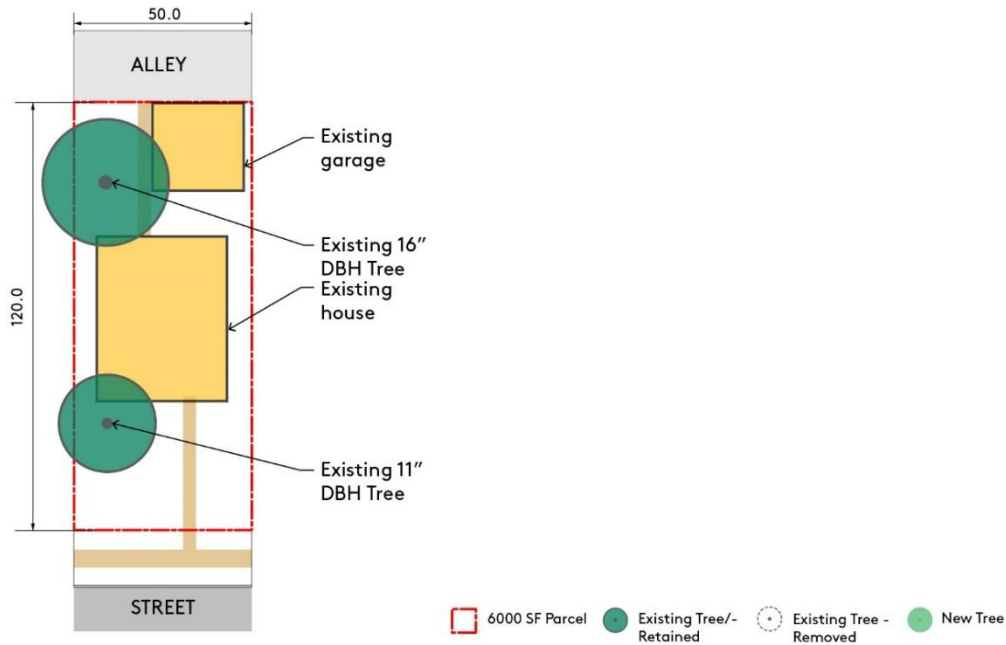

## 2. Proposed Development

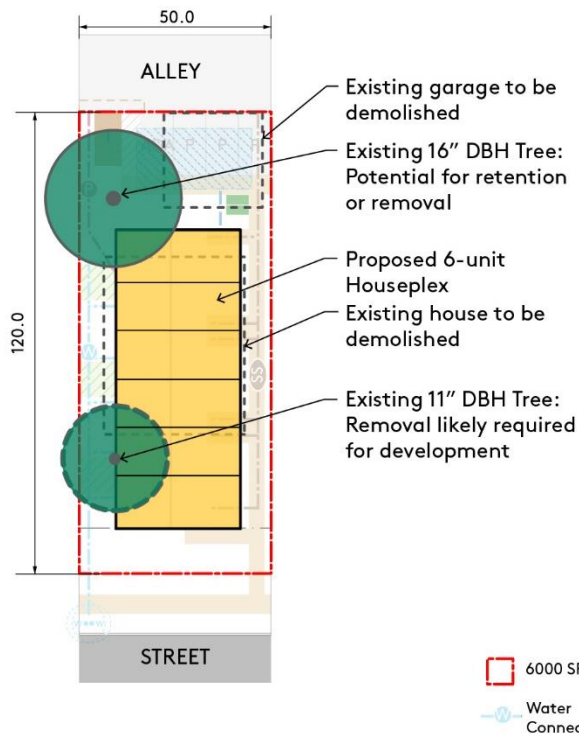

**NOTE:**  
Blue, brown and red lines indicate water, storm, sewer and power utilities. Amenity space, sidewalks, parking, bike parking, and solid waste storage are also represented. See HIT Site Planning Study dated September 2024.

### 3A. Scenario A - Retaining Trees

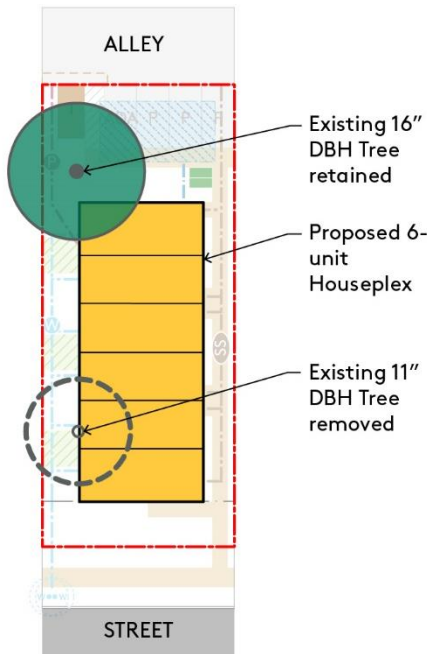

#### Tree Credits

##### Required Tree Credits: 1,200

A 6,000 sf lot in UR-3 requires tree credits corresponding to 20% of its lot area, or 1,200 credits.

##### Provided Tree Credits: 1,600

Retaining the 16" DBH tree meets the requirement for this lot (100 credits per inch = 1,600 credits).

**Tree Credit Fee: None**

#### Tree Removal

##### Canopy Loss Fee: None

One 11" DBH tree is removed to build the 6-unit houseplex. However, because tree credits are met through the retained 16" DBH tree and the removed tree is less than 18" DBH, the canopy loss fee is waived.



### 3B. Scenario B - Removing and Planting one large tree

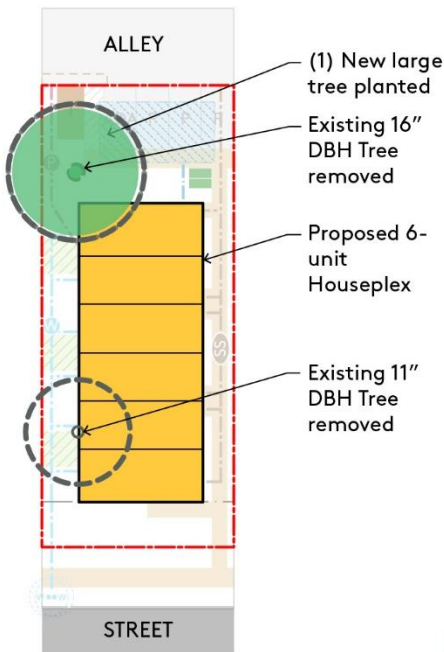

#### Tree Credits

##### Required Tree Credits: 1,200

A 6,000 sf lot in UR-3 requires tree credits corresponding to 20% of its lot area, or 1,200 credits.

##### Provided Tree Credits: 1000

1 large tree = 1000 credits. Fee required.

**Tree Credit Fee: \$3,000**

(\$15 per tree credit x 200 credits)

**Tree Credit Floor: 10% = 600 credits**

#### Tree Removal

##### Canopy Loss Fee: \$3,120

One 11" DBH tree and one 16" tree are removed, for a total of 27" removed. (1) 3" caliper tree planted. At \$130 per inch, the fee for removal would be \$3,120.

$(27'' \text{ removed}) - (3'' \text{ planted}) = 24'' \text{ Canopy Loss}$   
 $(24'') \times (\$130 \text{ per inch}) = \$3,120 \text{ Canopy Loss Fee}$



### 3C. Scenario C - Removing and Planting 3 medium trees

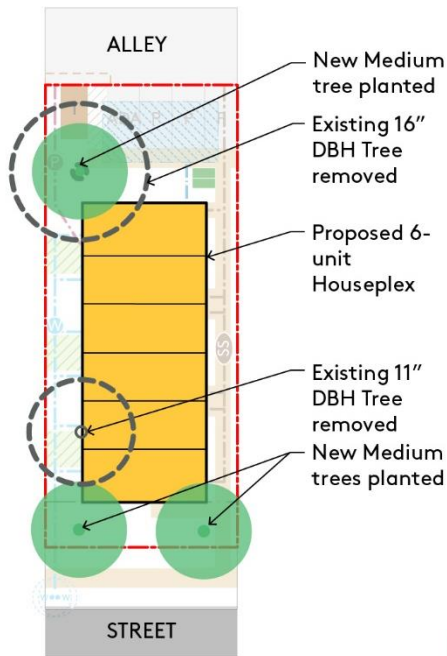

#### Tree Credits

**Required Tree Credits: 1,200**

A 6,000 sf lot in UR-3 requires tree credits corresponding to 20% of its lot area, or 1,200 credits.

**Provided Tree Credits: 1,500**

(3) Medium trees planted = 3 x 500 credits per tree = 1,500 credits.

**Tree Credit Fee: None**

#### Tree Removal

**Canopy Loss Fee: None**

Because tree credits are met through new tree planting, canopy loss fee is waived.



### 4. Site Proposal - Possible Outcomes

#### A. Retaining Trees

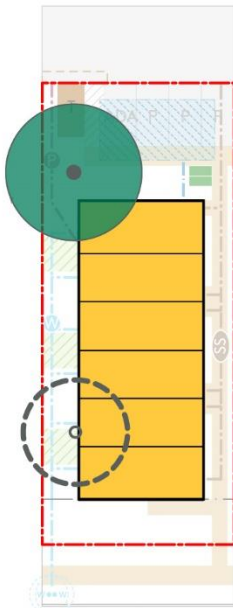

Required Tree Credits: 1200  
 Provided Tree Credits: 1600  
 Tree Credit Fee: None  
 Canopy Loss Fee: None

#### B. Removing & Planting one large tree

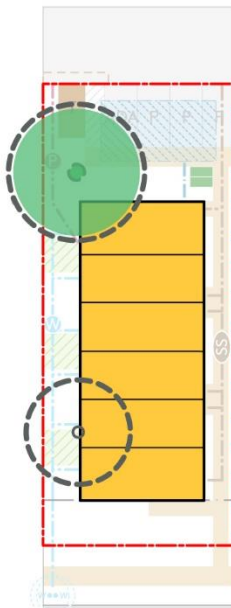

Required Tree Credits: 1200  
 Provided Tree Credits: 1000  
 Tree Credit Fee: \$3,000  
 Canopy Loss Fee: \$3,120

#### C. Removing & Planting 3 medium trees

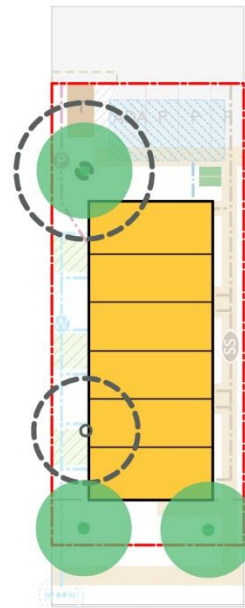

Required Tree Credits: 1200  
 Provided Tree Credits: 1500  
 Tree Credit Fee: None  
 Canopy Loss Fee: None

## Appendix 10: Plan Submittal Checklist

1. Site Survey
  - a. Provide a site survey clearly identifying existing site conditions, including all trees, tree sizes, tree protection zones, etc. (this may be included as a part of arborist report)
  - b. Ensure soil volume requirements are met on-site
2. Arborist Report
  - a. Include Arborist Report when applicable (e.g. when there are existing trees on site that are greater than 6” DBH)
3. Landscape Plan
  - a. Ensure the Landscape Plan relates to the civil plan
  - b. Ensure the Landscape Plan relates to the plant schedule
  - c. Landscape Plan must show existing trees and tree protection zones
4. Plant Schedule
  - a. Provide a Plant Schedule that includes species, quantities, and size designation (for trees).
  - b. Note compliance with any requirements (e.g. identifies “native” plants, when required)
5. Completed Tables
  - a. Submit complete tables with landscaping calculations that match site plans