



City of Tacoma, WA

TACOMA POWER/GENERATION

REQUEST FOR BIDS

CUSHMAN NO. 1 HEADGATE SEAL AND DRILL JIG

SPECIFICATION NO. PG25-0263N



**City of Tacoma
Tacoma Power/Generation**

**REQUEST FOR BIDS PG25-0263N
Cushman No. 1 Headgate Seal & Drill Jig**

Submittal Deadline: 11:00 a.m., Pacific Time, Friday, January 9, 2026

Submittals must be received by the City’s Procurement and Payables Division by 11:00 a.m. Pacific Time.

For electronic submittals, the City of Tacoma will designate the time of receipt recorded by our email server, as the official time of receipt. This clock will be used as the official time of receipt of all parts of electronic bid submittals. Include the specification number in the subject line of your email. Your submittal must be sent as an attachment, links to your electronic submittal will not be accepted.

For in person submittals, the City of Tacoma will designate the time of receipt recorded by the timestamp located at the lobby security desk, as the official time of receipt. Include the specification number on the outside of the envelope. Late submittals will be returned unopened and rejected as non-responsive.

Submittal Delivery: Submittals will be received as follows:

<p>By Email: sendbid@tacoma.gov Maximum email size, including attachments: 35 MB. Multiple emails may be sent for each submittal.</p> <p>Note: Email may pass through multiple servers before arriving at its destination. Please allow sufficient time for email delivery of submittals. Timely electronic delivery is at the risk of the supplier.</p>	<p>In Person: Tacoma Public Utilities Administration Building North, Main Floor, Lobby Security Desk 3628 South 35th Street Tacoma, WA 98409 Monday – Friday 8:00 am to 4:30 pm</p>
---	--

Solicitation Documents: An electronic copy of the complete solicitation documents may be viewed and obtained by accessing the City of Tacoma Purchasing website at www.TacomaPurchasing.org.

- [Register for the Bid Holders List](#) to receive notices of addenda, questions and answers and related updates.
- Click here to see a [list of vendors registered for this solicitation](#).

Pre-Proposal Meeting: A pre-proposal meeting will not be held.

Project Scope: The supply, machining, assembly, and delivery of the headgate seal and drill jig assemblies for the Cushman No. 1 Dam intake headgate.

Estimate: \$105,000

Paid Sick Leave: The City of Tacoma requires all employers to provide paid sick leave in accordance with Washington State law.

Americans with Disabilities Act (ADA Information): The City of Tacoma, in accordance with Section 504 of the Rehabilitation Act (Section 504) and the Americans with Disabilities Act (ADA), commits to nondiscrimination on the basis of disability, in all of its programs and activities. Specification materials can be made available in an alternate format by emailing the contact listed below in the *Additional Information* section.

Title VI Information: “The City of Tacoma” in accordance with provisions of Title VI of the Civil Rights Act of 1964, (78 Stat. 252, 42 U.S.C. sections 2000d to 2000d-4) and the Regulations, hereby notifies all bidders that it will affirmatively ensure that in any contract entered into pursuant to this advertisement, disadvantaged business enterprises will be afforded full and fair opportunity to submit bids in response to this invitation and will not be discriminated against on the grounds of race, color, national origin in consideration of award.

Additional Information: Requests for information regarding the specifications may be obtained by contacting Ivory Ramos by email to iramos@tacoma.gov.

Protest Policy: City of Tacoma protest policy, located at www.tacomapurchasing.org, specifies procedures for protests submitted prior to and after submittal deadline.



Meeting sites are accessible to persons with disabilities. Reasonable accommodations for persons with disabilities can be arranged with 48 hours advance notice by calling 253-502-8468.

TABLE OF CONTENTS

REQUEST FOR BIDS..... 2
TABLE OF CONTENTS..... 4
SUBMITTAL CHECK LIST 5
1. MINIMUM REQUIREMENTS 6
2. STANDARD TERMS AND CONDITIONS 6
3. DESCRIPTION OF WORK 6
4. ANTICIPATED CONTRACT TERM..... 6
5. CALENDAR OF EVENTS 6
6. INQUIRIES 6
7. PRE-BID MEETING 7
8. DISCLAIMER..... 7
9. RESPONSIVENESS 7
10. AWARD 7
11. DELIVERY 8
12. INSPECTION 8
13. COMPLIANCE WITH SPECIFICATIONS..... 9
14. MATERIALS AND WORKMANSHIP 9
APPENDIX A10
APPENDIX B27
APPENDIX C31

SUBMITTAL CHECK LIST

This checklist identifies items to be included with your submittal. Any submittal received without these required items may be deemed non-responsive and not be considered for award. Submittals must be received by the City of Tacoma Purchasing Division by the date and time specified in the Request for Bids page.

<p>The following items make up your complete electronic submittal package (include all the items below):</p>	
<p>Signature Page (Appendix B) To be filled in and executed by a duly authorized officer or representative of the bidding entity. If the bidder is a subsidiary or doing business on behalf of another entity, so state, and provide the firm name under which business is hereby transacted.</p>	
<p>Price Proposal Form (Appendix B) The unit prices bid must be shown in the space provided. Check your computations for omissions and errors.</p>	
<p>Record of Prior Contracts Form (Appendix B)</p>	
<p>After award, the following documents will be executed:</p>	
<p>City of Tacoma Contract (See sample in Appendix C) Must be executed by the successful bidder.</p>	

1. MINIMUM REQUIREMENTS

A. Only vendors experienced in this type of work, and with a record of successful completion of jobs of similar scope, will be considered for this contract. The City will be the sole judge of the vendor's ability to meet the requirements of this paragraph.

B. Bidders are required to submit, on the attached Contractor's Record of Prior Contracts form, a minimum of 3 references including date(s) and amount of contract, company name, contact person, and phone number.

2. STANDARD TERMS AND CONDITIONS

City of Tacoma [Standard Terms and Conditions](#) apply.

3. DESCRIPTION OF WORK

The City of Tacoma (City) / Tacoma Public Utilities (TPU) is soliciting bids to establish one or more contracts with qualified vendors to fulfill the City's needs for the supply, machining, assembly, and delivery of the headgate seal and drill jig assemblies for the Cushman No. 1 Dam intake headgate. Contract(s) will be awarded to the lowest responsive and responsible bidder(s) based on price, product quality, and availability.

4. ANTICIPATED CONTRACT TERM

This contract shall remain in effect until all goods have been delivered, inspected, and accepted by the City or until May 31, 2026, whichever occurs first.

5. CALENDAR OF EVENTS

This is a tentative schedule only and may be altered at the sole discretion of the City. The anticipated schedule of events concerning this RFB is as follows:

Publish and issue RFB:	12/17/2025
Question Deadline:	12/22/2025
City response to Questions:	12/29/2025
Submittal Due Date:	1/9/2026
Anticipated Award Date, on or about:	January 2026

6. INQUIRIES

6.1 Questions can be submitted to *Ivory Ramos*, Buyer, via email to iramos@tacoma.gov. Subject line to read: PG25-0263N – Cushman No. 1 Headgate Seal and Drill Jig – *VENDOR NAME*

6.2 Questions are due by 3 pm on the date included in the Calendar of Events section.

6.3 Questions marked confidential will not be answered or included.

6.4 The City reserves the discretion to group similar questions to provide a single answer or not to respond when the requested information is confidential.

6.5 The answers are not typically considered an addendum.

6.6 The City will not be responsible for unsuccessful submittal of questions.

6.7 Written answers to questions will be posted alongside these specifications at www.tacomapurchasing.org.

7. PRE-BID MEETING

No pre-proposal meeting will be held; however, questions and request for clarifications of the specifications may be submitted as stated in the [inquiries](#) section.

8. DISCLAIMER

The City is not liable for any costs incurred by the Respondent for the preparation of materials or a proposal submitted in response to this RFB, for conducting any presentations to the City, or any other activities related to responding to this RFB, or to any subsequent requirements of the contract negotiation process.

9. RESPONSIVENESS

Bid submittals must provide ninety (90) days for acceptance by City from the due date for receipt of submittals. All submittals will be reviewed by the City to determine compliance with the requirements and instructions specified in this RFB. The Respondent is specifically notified that failure to comply with any part of this RFB may result in rejection of the submittal as non-responsive. The City reserves the right, in its sole discretion, to waive irregularities deemed immaterial. The City also reserves the right to not award a contract or to issue subsequent RFB's

10. AWARD

Awardee shall be required to comply with 2 CFR part 25, and obtain a unique entity identifier and/or be registered in the federal System for Award Management as appropriate.

Award will be made to the lowest responsive, responsible bidder. All bidders shall provide unit or lump sum pricing for each line item. Each line item will be added up for a subtotal price. The subtotal price will be compared amongst each bidder, including any payment discount terms offered twenty (20) days or more. The City may also take into consideration all other criteria for determining award, including evaluation factors set forth in Municipal Code Section 1.06.262.

All other elements or factors, whether or not specifically provided for in this specification, which would affect the final cost to and the benefits to be derived by the City will be considered in determining the award of the contract. The final award decision will be based on the best interests of the City.

The City reserves the right to let the contract to the lowest responsible bidder whose bid will be the most advantageous to the City, price and any other factors considered. In evaluating the proposals, the City may also consider any or all of the following:

1. Compliance with specification.
2. Proposal prices, listed separately if requested, as well as a lump sum total
3. Time of completion/delivery.
4. Warranty terms.
5. Bidder's responsibility based on, but not limited to:
 - a) Ability, capacity, organization, technical qualifications and skill to perform the contract or provide the services required.
 - b) References, judgment, experience, efficiency and stability.
 - c) Whether the contract can be performed within the time specified.
 - d) Quality of performance of previous contracts or services

11. DELIVERY

11.1 Delivery shall be made to the City of Tacoma, Cushman Hydro Project Office, located at 21451 N. Highway 101, Shelton, WA 98584, Attn: Mike McCoy

11.2 Each vendor will be required to commit to a delivery timeline with a final delivery date no later than 98 days after the award of contract. Purchase order delivery dates will reflect this timeline. In the event a purchase order delivery date is not met, the City reserves the right to purchase these products elsewhere if they are in a time constraint. If constant late deliveries occur, the City may terminate the contract.

11.3 Hours of operation shall be Monday through Thursday, 7:00 a.m. to 3:30 p.m., excluding legal holidays, as referred to in the Standard Terms and Conditions or as otherwise approved by the City. Delivery will not be accepted outside of these dates and times or without advance notice.

12. INSPECTION

The manufacturer shall invite the City Engineer to inspect the product at hold points and before shipping from the shop or factory. Vendor shall provide five business days of notice in advance of shop inspections. **See note 4 on drawing BA150 and note 2 on drawing BA153-S1.**

All goods are subject to final inspection and acceptance by the City. If any inspection fails, the vendor shall be required to make arrangements to modify or exchange the goods at their own expense and replace them in a timely manner acceptable to the City.

Material failing to meet the requirements of this contract will be held at Vendor's risk and may be returned to Vendor. If so returned, the cost of transportation, unpacking, inspection, repackaging, reshipping, or other like expenses are the responsibility of the Vendor.

13. COMPLIANCE WITH SPECIFICATIONS

All products shall be new and unused. Any product that does not comply with any part of these technical specifications shall be rejected and the vendor shall, at its own expense, including shipping, replace the item.

14. MATERIALS AND WORKMANSHIP

The successful bidder shall be required to furnish all materials necessary to perform contractual requirements. Materials and workmanship for this contract shall conform to all codes, regulations and requirements for such specifications contained herein and the normal uses for which intended. Material shall be manufactured in accordance with the best commercial practices and standards for this type of goods. All literature and products must be packaged and labeled to sell in the United States.

APPENDIX A

Special Provisions & Technical Specifications

Drawings

MASTER SUPPLY SPECIFICATION

SPECIFICATION NO. PG25-0263N

These Special and Technical Specifications have been prepared under the direction of a licensed Professional Engineer, registered in the State of Washington

TABLE OF CONTENTS

SPECIAL PROVISIONS

- 1. MATERIAL SHIPPING QUANTITIES**
- 2. PROJECT COORDINATION**
- 3. PROPOSAL ITEMS**
- 4. ADMINISTRATION - MEASUREMENT AND PAYMENT**
- 5. CONTRACT CHANGES**
- 6. MAINTENANCE AND OPERATION MANUALS AND DRAWINGS**
- 7. PACKING AND SHIPPING**
- 8. INVOICING**

TECHNICAL SPECIFICATIONS

MATERIAL TO BE SUPPLIED

SPECIAL PROVISIONS

1. MATERIAL SHIPPING QUANTITIES

Two (2) Headgate Seals will be ordered per drawings BA150 through BA152, and one Headgate Seal Drill Jig Assembly per drawings BA153-S1 through BA153-S4.

2. PROJECT COORDINATION

A. Management for this project, with whom the vendor shall coordinate all their activities, will be Mr. Steve Belvin, at 253-502-8104 (desk), 253-278-3416 (cell).

3. PROPOSAL ITEMS

- A. Refer to Proposal for Specification page(s) for a listing of the required bid item.
- B. Bid item shall be measured by unit payment price per each (EA) unless otherwise noted and shall be full and complete compensation including delivery (see Delivery section).

4. ADMINISTRATION - MEASUREMENT AND PAYMENT

A. UNIT QUANTITIES SPECIFIED

See the Proposal page for quantities.

B. CONTRACT PRICE

The unit bid prices shall be full and complete compensation for the contract work stated, together with all appurtenances incidental thereto, including materials, equipment, tools, labor, and all the costs to the vendor for completing the contract in accordance with the plans, specifications, and instructions of the engineer.

All work not specifically called out in these specifications but required to construct complete and operable systems, structures, or amenities shall be considered incidental to the contract.

C. PROPOSAL ITEMS

1. ITEM 1 HEADGATE SEAL ASSEMBLY, AS SPECIFIED

MEASUREMENT

Items 1 Headgate Seal Assembly, As Specified, shall be measured per each (EA).

PAYMENT

The contract unit price per each (EA) shall be full compensation for all costs associated with supply and delivery of Items 1 Headgate Seal Assembly, As Specified, and in accordance with the attached specifications.

2. ITEM 2 HEADGATE SEAL DRILL JIG, AS SPECIFIED

MEASUREMENT

Items 2 Headgate Seal Drill Jig, As Specified, shall be measured per each (EA).

PAYMENT

The contract unit price per each (EA) shall be full compensation for all costs associated with supply and delivery of Items 2 Headgate Seal Drill Jig, As Specified, and in accordance with the attached specifications.

5. **CONTRACT CHANGES**

The City has developed four (4) forms to facilitate and track communications with the vendor. These are the **Request for Information (RFI)**, **Engineering Change Directive (ECD)**, **Proposal Request (PR)**, and **Change Order Proposal (COP)**. These forms are included at the end of the Special Provisions.

The **Request for Information (RFI)** shall be used by the vendor whenever written direction on conflicts in plans, insufficient or unconstructable detail is shown, or any other issue, which should be documented, arises. The City may also use the form to inquire on vendor's methods, schedule or other issues not warranting more formal letter correspondence. The vendor shall maintain the numbering system and, as such, any issued by the City will be unnumbered until delivered to the vendor.

The **Engineering Change Directive (ECD)** shall be used by the City to transmit new or revised drawings, issue additions or modifications to the contract or furnish any other direction, which should be documented. Directives are effective immediately. Should the vendor believe that such Directive should result in either a change in cost or time for the project, they shall notify the engineer prior to commencing such work and, if possible, submit a **Change Order Proposal** prior to the start of such work, but in no case, less than seven (7) days from receipt of said Directive. Should no Change Order Proposal be received by the City within seven (7) days, such claim for extra cost or time shall be presumed to be dropped. Directives are numbered by the City.

The **Proposal Request (PR)** shall be used by the City to request pricing on a possible change in plans or additional work. The PR may also be used to request credits for deletion or changes in scope of work. The vendor shall respond to such requests with a **Change Order Proposal** within seven (7) days from receipt of said Request unless more time has been agreed to. Requests are numbered by the City.

The **Change Order Proposal (COP)** shall be used by the vendor to respond to City issued Proposal Requests, Engineering Change Directives or when the vendor believes that changed conditions or omitted, but necessary, work items exist. The COP may be used for requested changes in cost or time of the contract. COPs shall be numbered by the vendor and, in the case of revision or resubmission of the same basic COP, the number shall be hyphenated with the letter "B", "C", etc.

6. **MAINTENANCE AND OPERATION MANUALS AND DRAWINGS**

No maintenance and operations (O&M) manuals are required.

7. **PACKING AND SHIPPING**

A. VENDOR RESPONSIBILITIES

The vendor shall be responsible for industry standard packing, which conforms to requirements of the carrier's tariffs and ICC regulations. Containers must be clearly marked as to lot number, destination, address, engineer, purchase order number and release number.

B. PREPARATION FOR SHIPMENT

All items shall be properly prepared for shipment.

The vendor will be responsible for all damage to the shipment incurred in transit.

C. SHIPPING

Shipping as detailed under this paragraph will constitute the only shipping instructions under these specifications. All items shall be shipped F.O.B. destination, pre-paid and allowed to the destinations stated herein. A complete packing list must be included.

8. INVOICING

A. The vendor shall submit a detailed invoice upon completion of delivery and acceptance of the drill jig and seal assemblies by the City of Tacoma.

B. Invoices shall include, at a minimum:

1. Purchase Order or Contract number
2. Description of goods delivered
3. Quantity and unit price
4. Total amount due
5. Delivery date
6. Name and contact information of the vendor representative

C. All invoices must be submitted electronically to:

City of Tacoma – Steve Belvin
Email: sbelvin@tacoma.gov

END OF SECTION

TECHNICAL SPECIFICATIONS

MATERIAL TO BE SUPPLIED

PART 1 GENERAL

1.01 SUMMARY

A. Section includes the furnishing, machining, assembly, inspection, and delivery of a custom seal and drill jig for the Cushman No. 1 intake headgates, constructed in full accordance with the provided engineering drawings and specifications.

B. Work includes:

1. Supply of seal and drill jig materials and associated components
2. Cutting and machining to specified lengths
3. Seal assembly, jig assembly, and shop inspection by the City Engineer.
4. Use of jig assembly as a template to transfer holes onto the seal assemblies
5. Packaging and delivery to the site

1.02 REFERENCES

A. The following standards apply where referenced:

1. Engineering Drawing No(s): BA150, BA151, BA152, BA153-S1, BA153-S2, BA153-S3 AND BA153-S4

PART 2 PRODUCT

2.01 GENERAL

A. All components must be fabricated per the dimensions, tolerances, and materials called out in the supplied engineering drawings.

B. Fabricator shall not deviate from the design documents unless written approval is provided by the Engineer.

PART 3 EXECUTION

3.01 FABRICATION

A. Seal and drill jig shall be fabricated, machined, or welded (if applicable) to exact dimensions provided.

3.02 QUALITY CONTROL

A. All components shall be inspected for:

1. Materials Certifications
2. Dimensional tolerances per specification drawings.



REQUEST FOR INFORMATION (RFI)

(This form shall be used by the contractor whenever written direction on conflicts in plans, insufficient or unconstructable detail is shown, or any other issue which should be documented arises; or by the City when additional clarification is required.)

RFI No.: (Contractor Assigns)

Date: _____
 Project Title: _____
 Specification No.: _____ Contract No.: _____

Contractor: _____ **Owner:** Tacoma Power/Generation
 3628 South 35th Street
 Tacoma, WA 98409

Subject: _____

Architectural Civil Structural Mechanical Electrical Other

Requested Information:

Attachment Type: _____ Initiated By: _____
(Supporting Documentation) (Name)

Response Required: _____ Representing: _____
(Date) (Company)

Response:

Attachment Type: _____ Response By: _____
(Supporting Documentation) (Name)

Representing: _____
(Company)

*Prior to any extra work the contractor shall submit a written **Change Order Proposal (COP)**. See Section 01040, Contract Changes, of the specification for this Contract.*

Response Date: _____
(Date)

City Approval:

The owner (Tacoma Power) reviewed the foregoing request and finds the response to be in order.

Project Engineer: _____ Response Date: _____
(Name) (Date)

Cc:

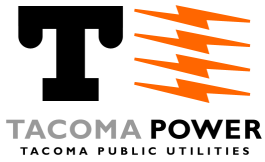

PROPOSAL REQUEST (PR)

(This form shall be used by the City to request pricing on a possible change in plans or additional work. The PR may also be used to request credits for deletion or changes in scope of work.)

PR No.: (City Assigns)

Date: _____

Project Title: _____

Specification No.: _____ Contract No.: _____

Contractor:

Owner:

Tacoma Power/Generation
3628 South 35th Street
Tacoma, WA 98409

Subject: _____

Architectural Civil Structural Mechanical Electrical Other

Scope of Request:

Attachment Type: _____
(Supporting Documentation)

This is not a change order or a notice to proceed with the described work. Prior to any extra work the contractor shall submit a written **Change Order Proposal (COP). See Section 01040, Contract Changes, of the specification for this Contract.**

Initiated By: _____
(Name)

Representing: _____
(Company)

Cc:



CHANGE ORDER PROPOSAL (COP)

(This form shall be used by the contractor to respond to City issued Proposal Requests, Engineering Change Directives or when the contractor believes that changed conditions or omitted, but necessary, work items exist. The COP may be used for requested changes in cost or time of the contract.)

COP No.: (Contractor Assigns)

REF. Doc.: (Initiating a RFI, ECD or PR)

Date: _____

Project Title: _____

Specification No.: _____ Contract No.: _____

Contractor:

Owner:

Tacoma Power/Generation
3628 South 35th Street
Tacoma, WA 98409

Title: _____

Architectural Civil Structural Mechanical Electrical Other

Scope of Change:

Initiated By: _____ Representing: _____
(Name) (Company)

Cost/Credit: _____ Time Extension Request: _____

Attachment Type: _____
(Supporting Documentation)

This change order proposal shall include ALL labor, material, equipment, subcontractor costs, mark-ups including overhead, profit, any other direct and/or indirect costs, and any requests for additional time associated with the change in the scope of work.

City's Response:

Action: Approved Unapproved Revise and Resubmit (Select only one)

*Prior to any extra work the contractor shall submit a written **Change Order Proposal (COP)**. See Section 01040, Contract Changes, of the specification for this Contract.*

Response By: _____ Attachment Type: _____
(Name) (Supporting Documentation)

Representing: _____ Response Date: _____
(Company) (Date)

Cc:

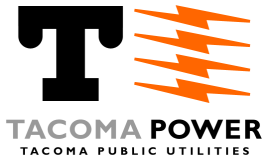

ENGINEERING CHANGE DIRECTIVE (ECD)

(This form shall be used by the City to transmit new or revised drawings, issue additions or modifications to the contract or furnish any other direction which should be documented.)

ECD No.: (City Assigns)

Date: _____

Project Title: _____

Specification No.: _____ Contract No.: _____

Contractor:

Owner:

Tacoma Power/Generation
3628 South 35th Street
Tacoma, WA 98409

Title: _____

Architectural Civil Structural Mechanical Electrical Other

You are hereby directed to make the following modification(s) in the Scope of Work in this Contract:

This document becomes effective upon receipt by the Contractor, with signature of an approved City representative. The Contractor shall then commence with modification(s) listed above.

Attachment Type: _____
(Supporting Documentation)

Initiated By: _____
(Name)

Representing: _____
(Company)

Contractor's Response:

This ECD: Will Not May Will (select one box only) result in a claim by the Contractor.

*Prior to any extra work the contractor shall submit a written **Change Order Proposal (COP)**. See Section 01040, Contract Changes, of the specification for this Contract.*

Attachment Type: _____
(Supporting Documentation)

Response By: _____
(Name)

Response Date: _____
(Date)

Representing: _____
(Company)

Cc:

ITEM NO.	DETAILED	PART NUMBER	MANUFACTURER	DESCRIPTION	LENGTH	QTY.
1	BA151	BA150-1		FB 0.1875 X 2	3'-8"	1
2	BA152	BA150-2		FB 0.1875 X 2	4'-2 1/2"	1
3	BA152	BA150-3		FB 0.1875 X 2	4'-2 1/2"	1
4	BA152	BA150-4		FB 0.1875 X 2	4'-4"	1
5	BA151	BA150-5		FB 0.1875 X 2	3'-8"	1
6	BA151	BA150-6		FB 0.1875 X 2	3'-7 1/2"	1
7	BA152	BA150-7		FB 0.1875 X 2	4'-4"	1
8	BA152	BA150-8		FB 0.1875 X 2	4'-2 1/2"	1
9	BA152	BA150-9		FB 0.1875 X 2	4'-2 1/2"	1
10	BA151	BA150-10		FB 0.1875 X 2	3'-7 1/2"	1
11	NO	O-Ring	GRAINGER		100'	1

REFERENCE DRAWINGS

BA151	HEADGATE SEAL HORIZONTAL MEMBER DETAILS
BA152	HEADGATE SEAL VERTICAL MEMBER DETAILS
BA153-S1 to S4	HEADGATE SEAL DRILL JIG
BA1601	HEADGATE ELEVATION VIEWS
BA1602	HEADGATE SECTIONS, VIEWS AND DETAILS
BA1603	HEADGATE VIEWS AND DETAILS

NOTES

1. MATERIAL: C360 YELLOW BRASS
2. USE DRILL JIG BA153 TO LOCATE OR VERIFY HOLE LOCATIONS. DEMONSTRATE TO THE CITY ENGINEER AS AN INSPECTION POINT.
3. QUANTITIES SHOWN ARE FOR ONE SEAL. THIS CONTRACT ORDERS TWO SEALS.
4. SHOW ASSEMBLED SEAL TO THE CITY ENGINEER AS AN INSPECTION POINT.

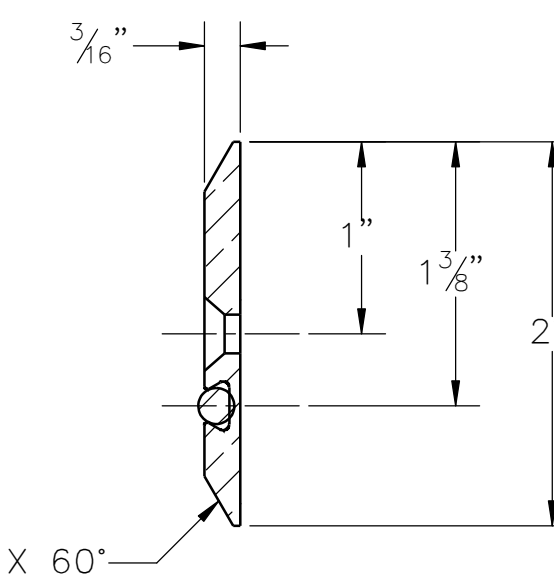

SECTION A-A
SCALE: 1:1

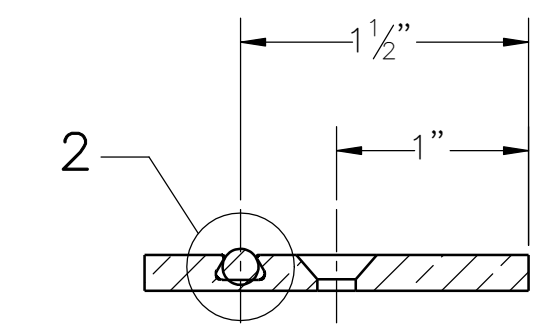

SECTION B-B
SCALE: 1:1

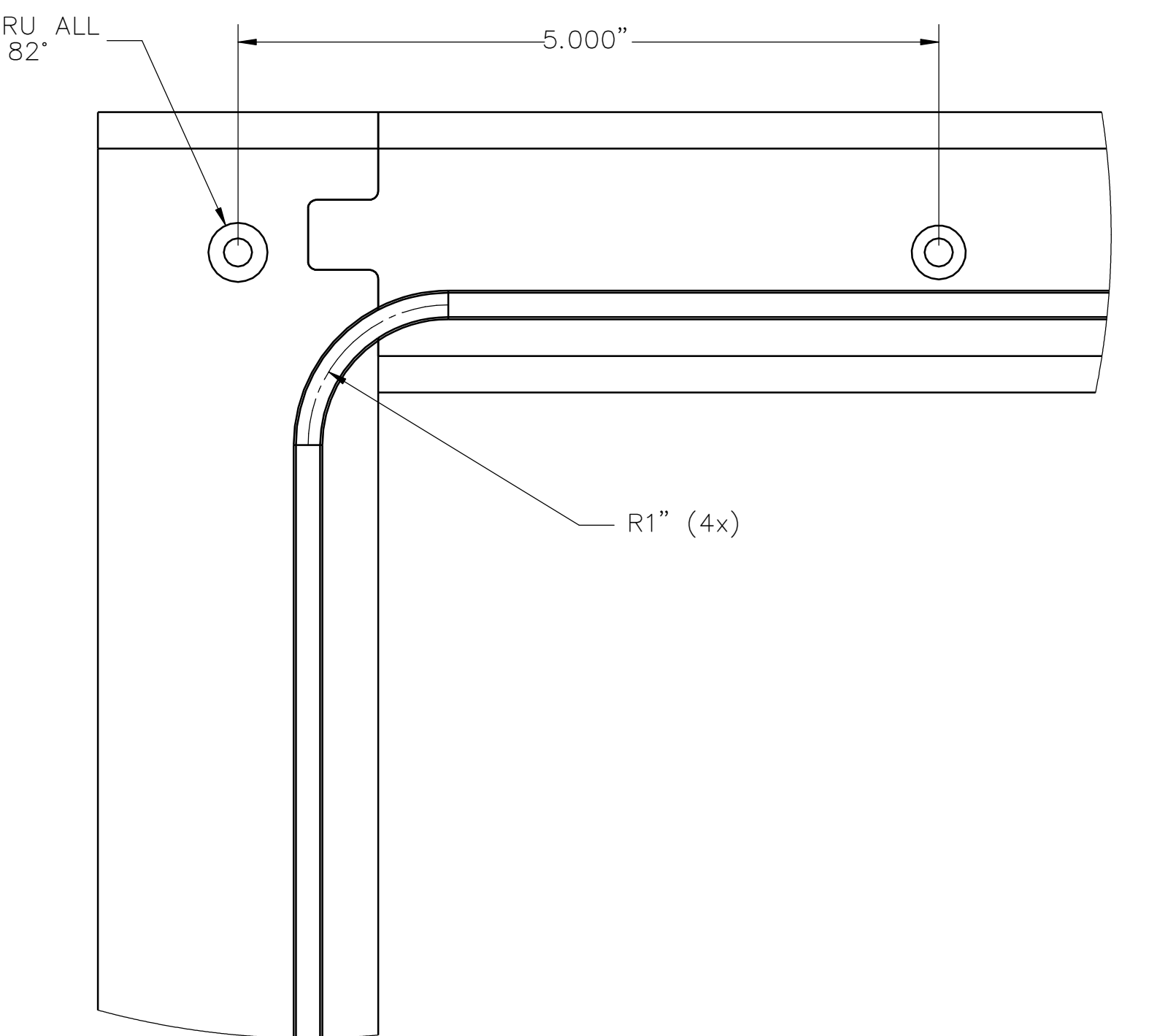

DETAIL 1
SCALE: 1:1

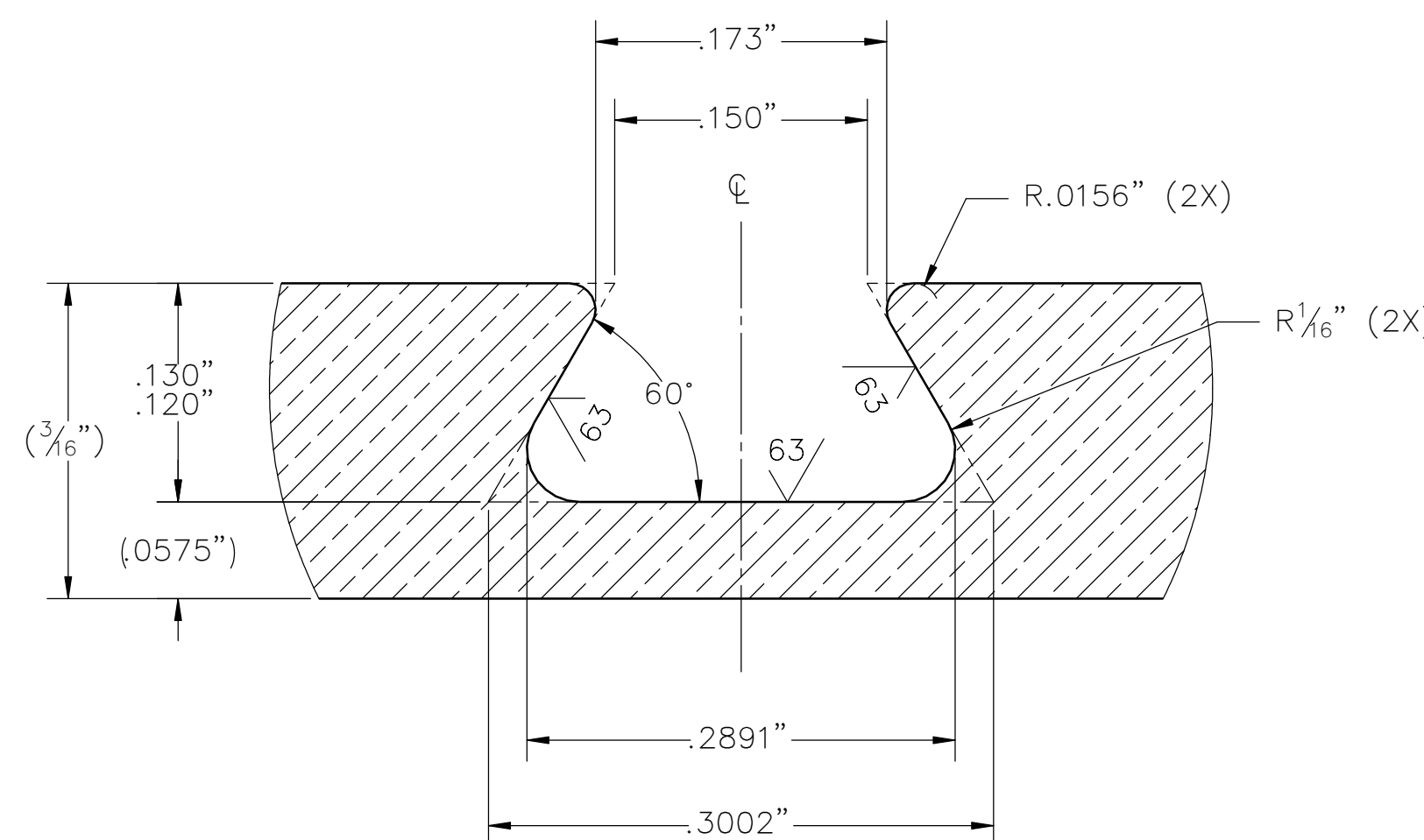

DETAIL 2
SCALE: 10:1

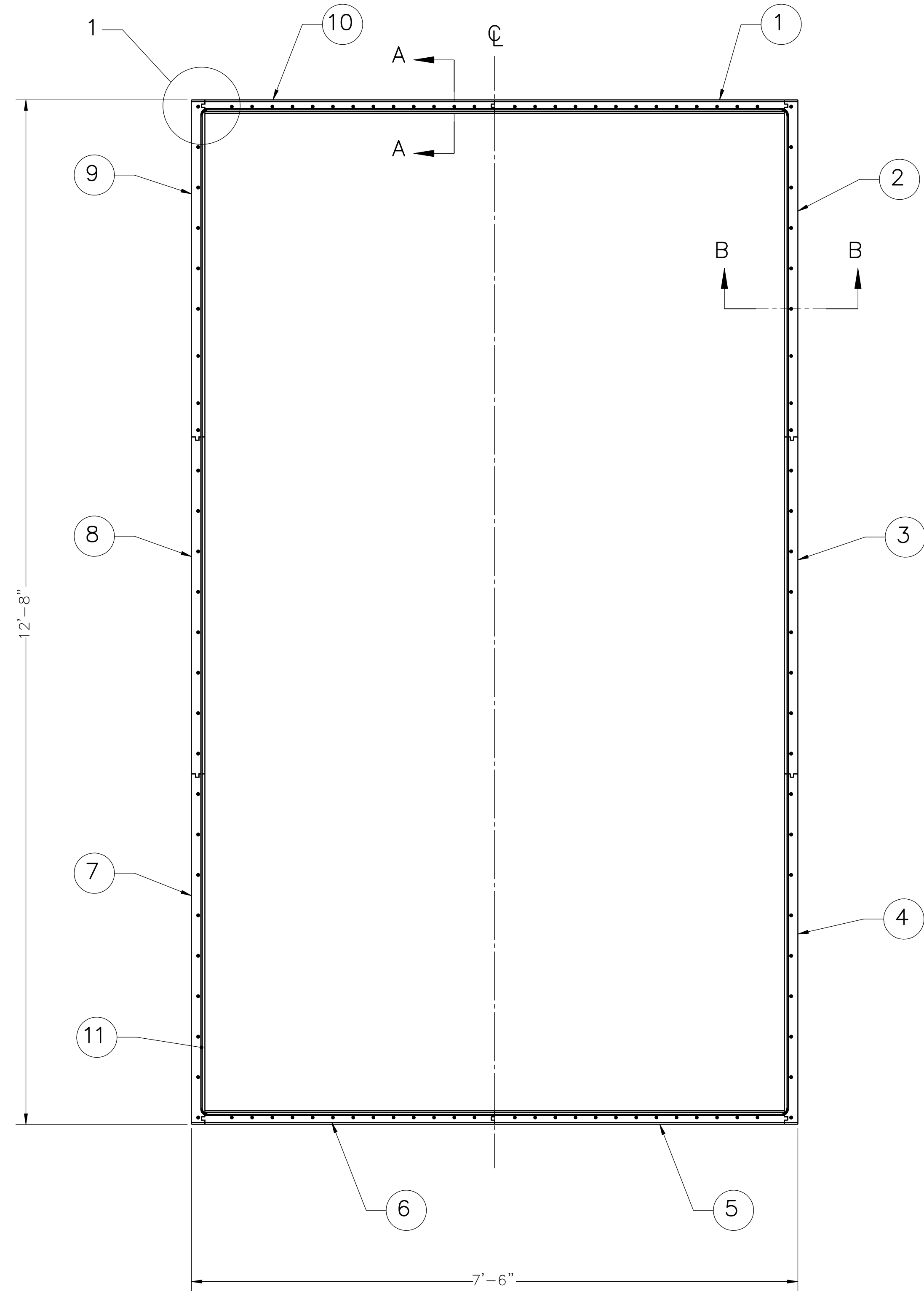

HEADGATE SEAL ASSEMBLY
SCALE: 1" = 1'-0"

MACHINING NOTES

1. BREAK ALL SHARP EDGES
2. MAKE NO MATERIAL SUBSTITUTIONS WITHOUT APPROVAL OF THE ENGINEER.
3. FINISH $\sqrt{\text{ALL OVER}}$ UNLESS NOTED OTHERWISE.

MACHINING TOLERANCES UNLESS OTHERWISE NOTED:
FRACTIONAL $\pm 1/64$
DECIMAL ± 0.010
ANGLE $\pm 1^\circ$

CITY OF TACOMA
DEPARTMENT OF PUBLIC UTILITIES
LIGHT DIVISION

REV. NO. A

CUSHMAN 1 DAM
HEADGATE SEAL
ASSEMBLY,
BOM & DETAILS

SUBMITTED	DRAWN	STAMPED
	KJA	
DATE	SCALE	AS SHOWN

DRAWING NO.
BA150

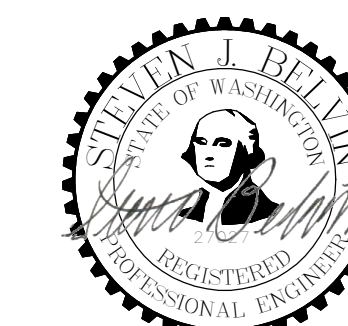

FOR CONSTRUCTION ONLY

Submitted By: STEVE J. BELVIN Date: 12/4/2025

Approved By: TYLER W. BRAUN Date: 12/3/2025

CUSHMAN 1 HEADGATE SEAL

Noted By: KJA Construction Rev:

REFERENCE DRAWINGS

BA150	HEADGATE SEAL ASSEMBLY, BOM & DETAILS
BA152	HEADGATE SEAL VERTICAL MEMBER DETAILS
BA153-S1 to S4	HEADGATE SEAL DRILL JIG
BA1601	HEADGATE ELEVATION VIEWS
BA1602	HEADGATE SECTIONS, VIEWS AND DETAILS
BA1603	HEADGATE VIEWS AND DETAILS

NOTES

- SEE DRAWING BA150 FOR GENERAL NOTES.
- USE OR VERIFY MATCH TO DRILL JIG, SEE BA150 NOTE 2.
- MATCH MARK ALL CONNECTION POINTS IDENTIFYING THE SEAL NUMBER AND CONNECTION AS FOLLOWS: FOR SEAL NO. 1 AT CONNECTION A-A, STAMP '1A' ON EACH PART ADJACENT TO THE CONNECTION. ADDITIONALLY, STAMP 'TOP' ON THE TWO TOP PIECES.

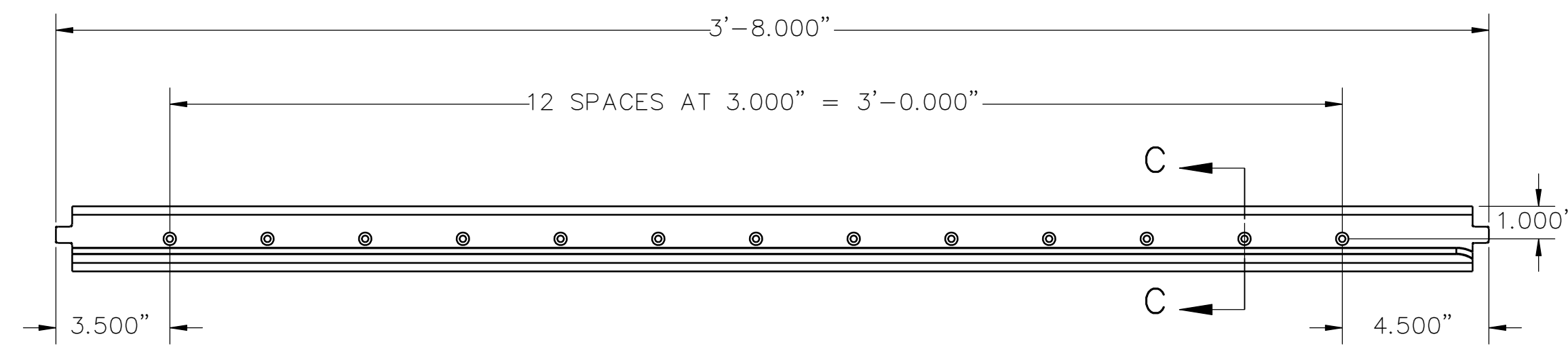

1 TOP RIGHT
SCALE: 3" = 1'-0" 3

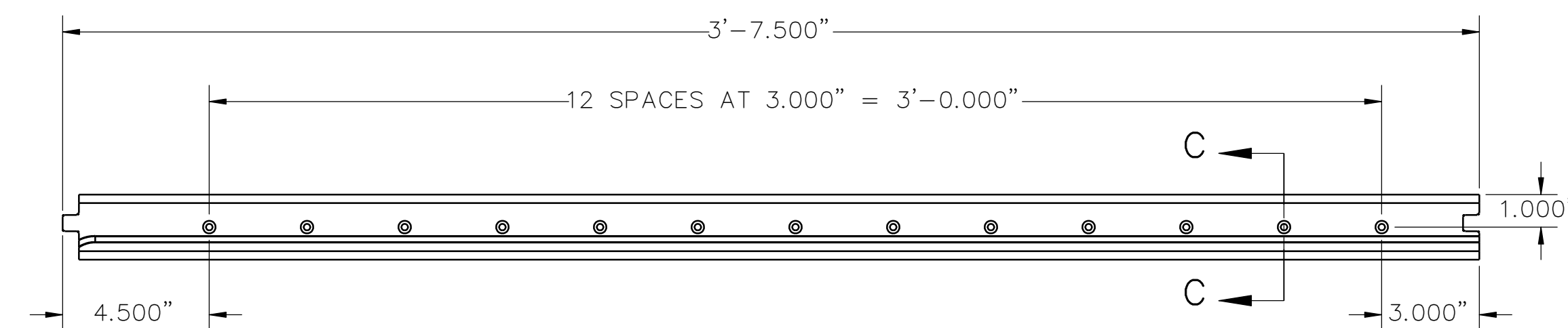

10 TOP LEFT
SCALE: 3" = 1'-0" 3

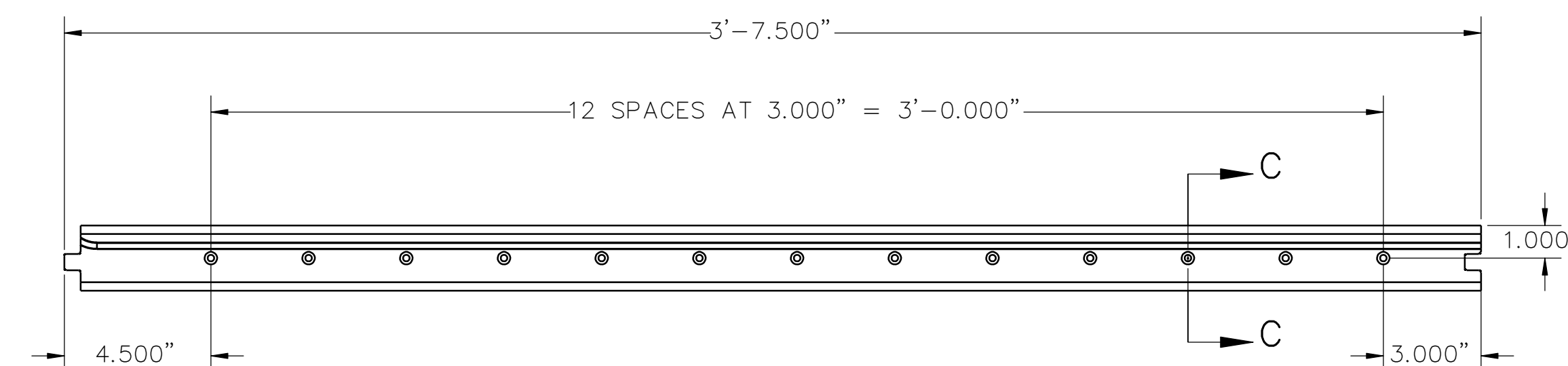

6 BOTTOM LEFT
SCALE: 3" = 1'-0"

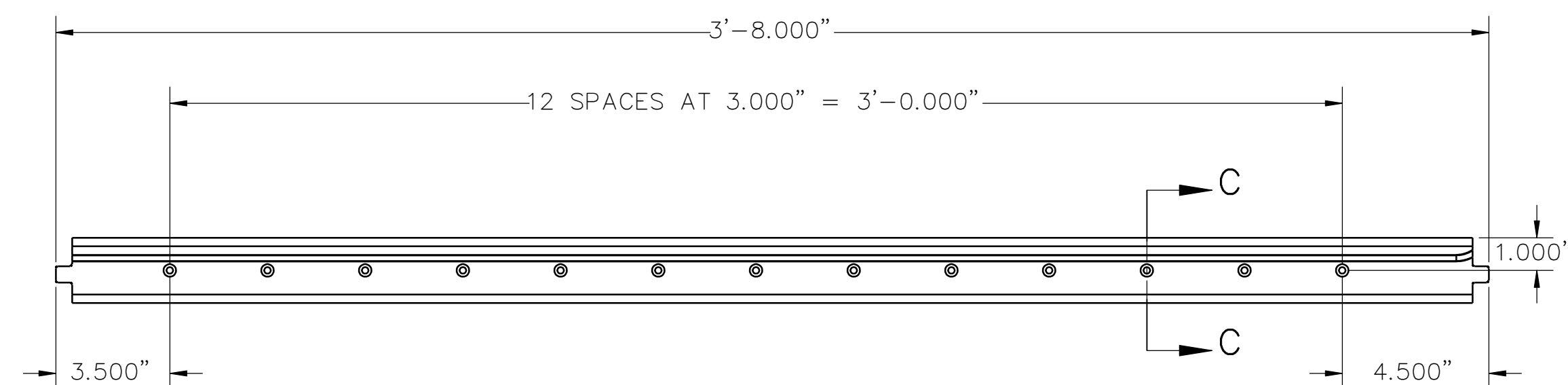

5 BOTTOM RIGHT
SCALE: 3" = 1'-0"

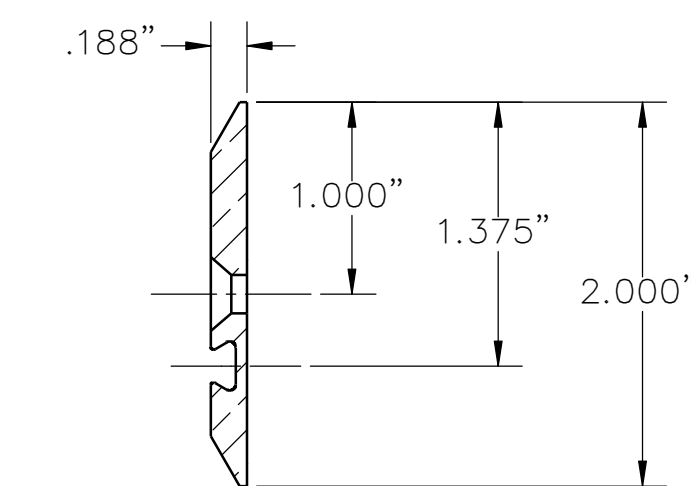

SECTION C-C

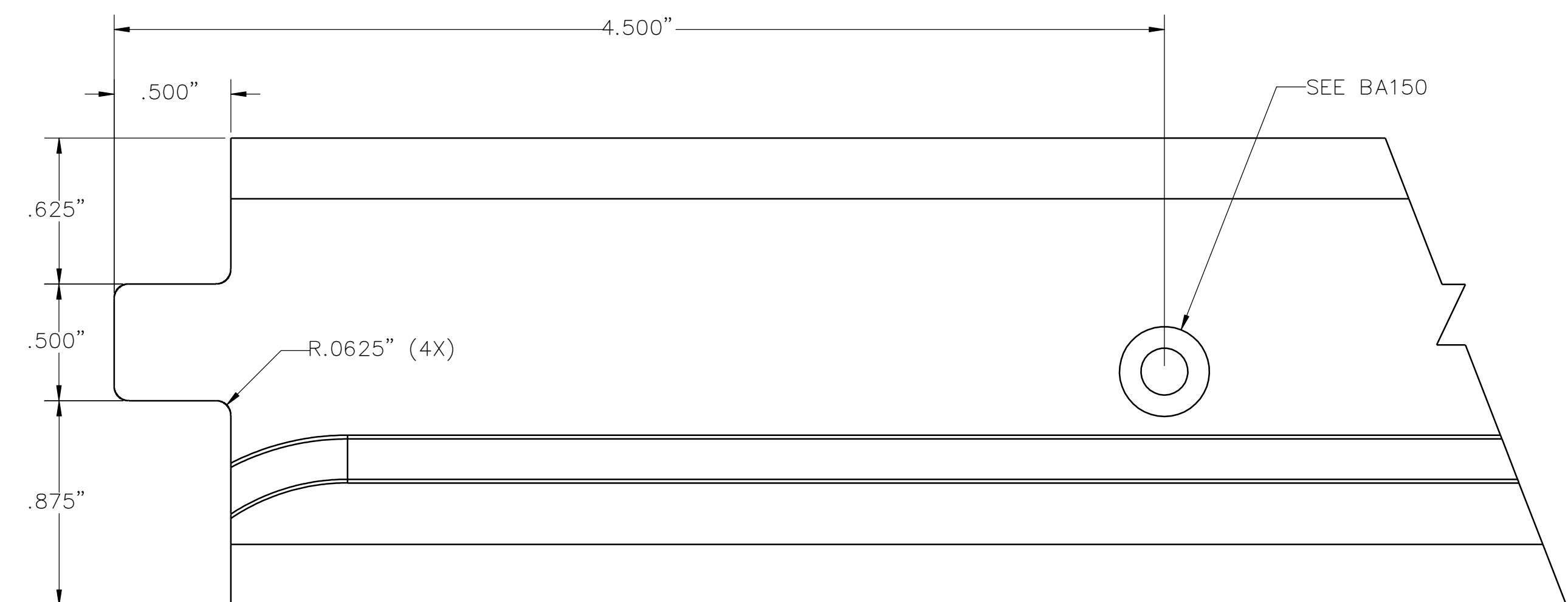

TOP LEFT CONNECTION
SCALE: 2:1

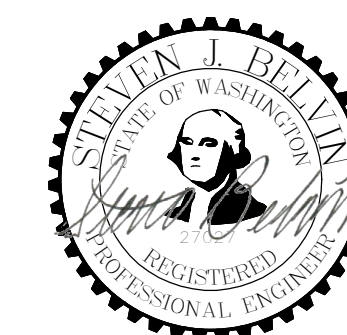

FOR CONSTRUCTION ONLY	
Submitted By: <u>STEVE J BELVIN</u>	Date: <u>12/4/2025</u>
Approved By: <u>TYLER W BRAUN</u>	Date: <u>12/3/2025</u>
CUSHMAN 1 HEADGATE SEAL	
Drawn By: <u>KJA</u>	Construction Rev: _____

MACHINING TOLERANCES UNLESS OTHERWISE NOTED: FRACTIONAL ±1/64 DECIMAL ±.010 ANGLE ±1°		CITY OF TACOMA DEPARTMENT OF PUBLIC UTILITIES LIGHT DIVISION	
REV. NO. A		CUSHMAN 1 DAM HEADGATE SEAL HORIZONTAL MEMBER DETAILS	
SUBMITTED	DRAWN KJA	DATE	STAMPED
APPROVED	SCALE AS SHOWN	DRAWING NO. BA151	

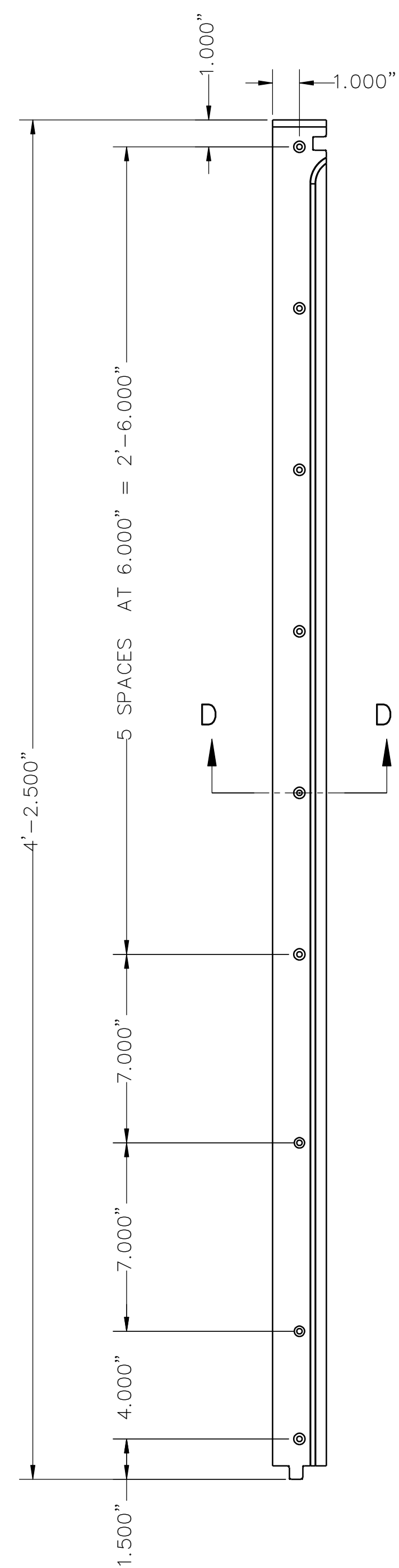

9 UPPER LEFT
SCALE: 3" = 1'-0"

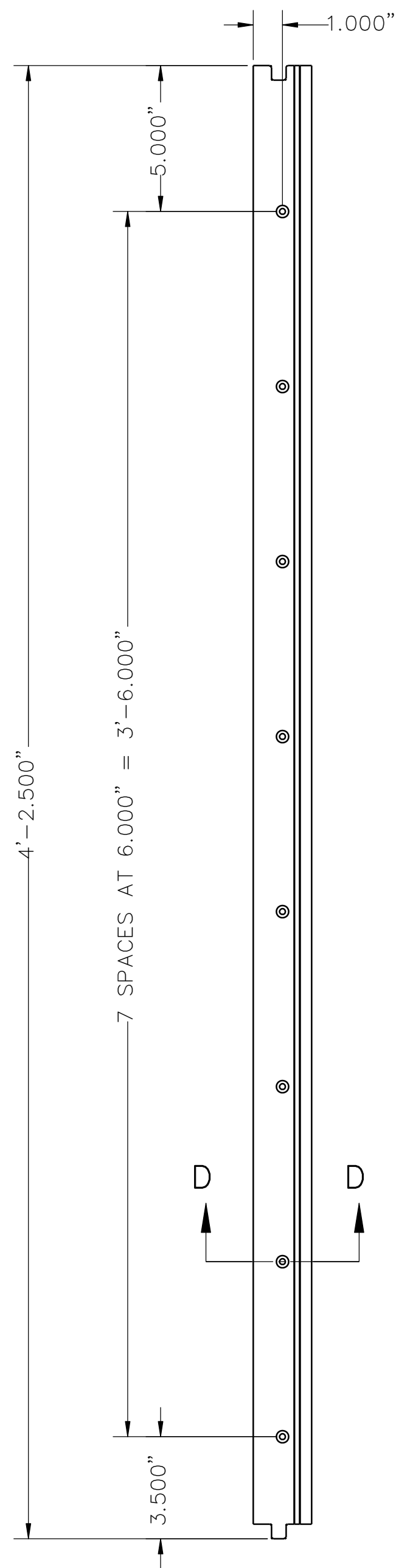

8 MIDDLE LEFT
SCALE: 3" = 1'-0"

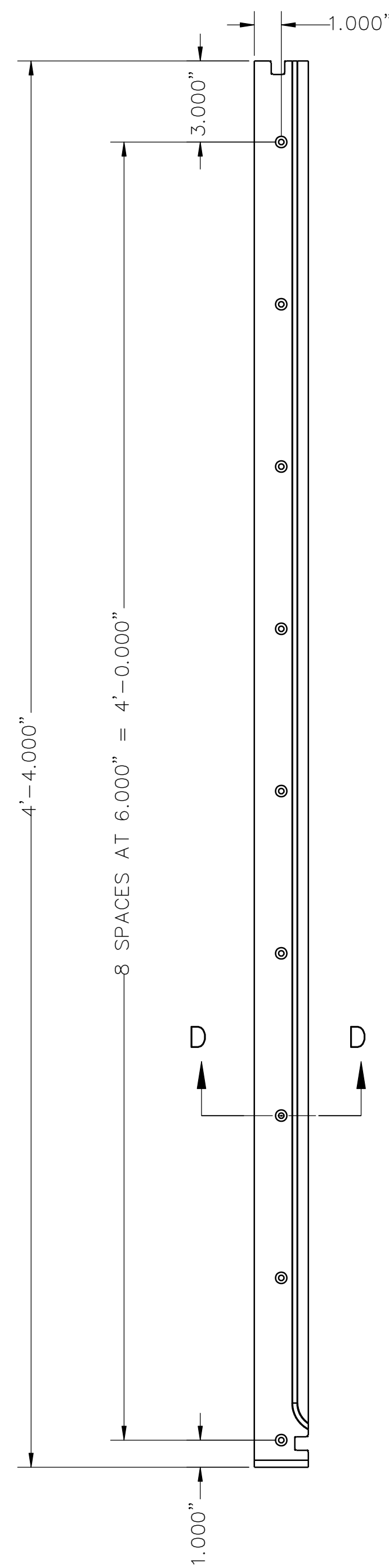

7 LOWER LEFT
SCALE: 3" = 1'-0"

2 UPPER RIGHT SIM, OP. HAND

3 MIDDLE RIGHT SIM, OP. HAND

4 LOWER RIGHT SIM, OP. HAND

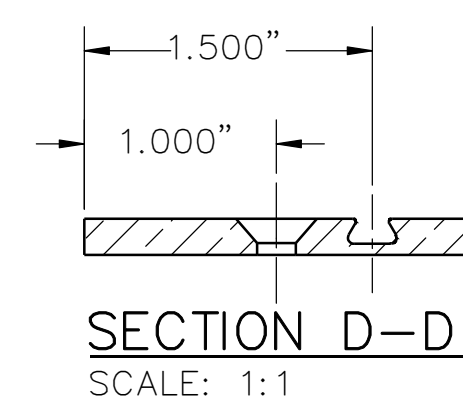

SECTION D-D
SCALE: 1:1

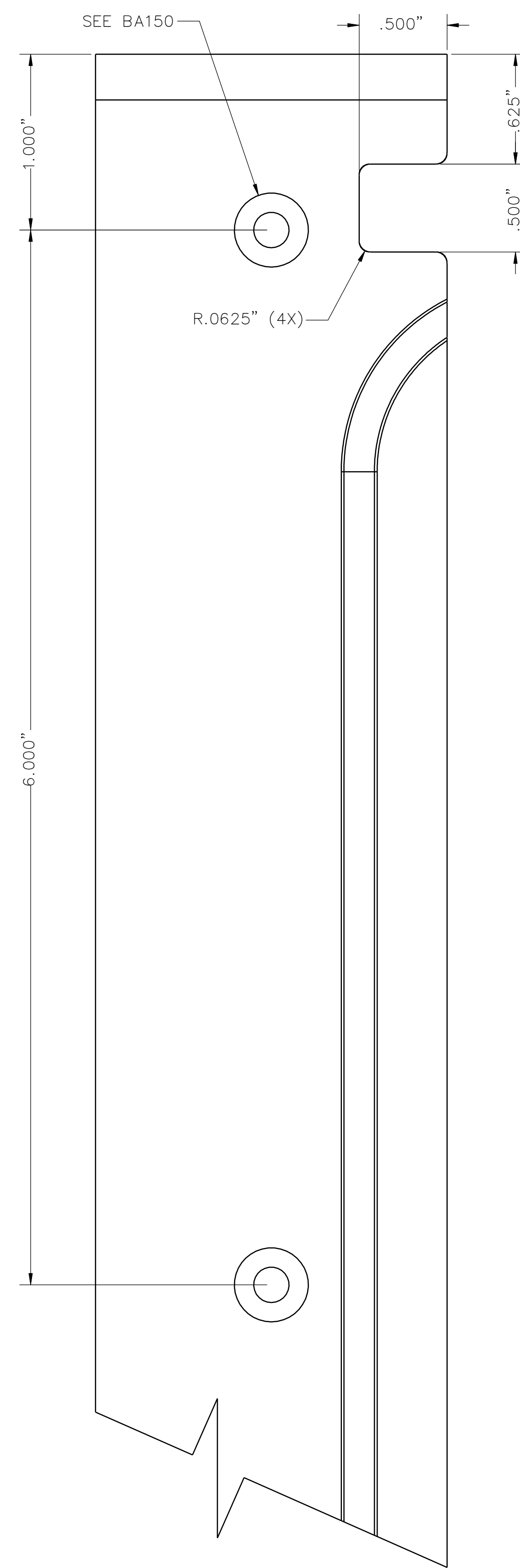

UPPER LEFT CONNECTION
SCALE: 2:1

REFERENCE DRAWINGS

BA150	HEADGATE SEAL ASSEMBLY, BOM & DETAILS
BA151	HEADGATE SEAL HORIZONTAL MEMBER DETAILS
BA153-S1 to S4	HEADGATE SEAL DRILL JIG
BA1601	HEADGATE ELEVATION VIEWS
BA1602	HEADGATE SECTIONS, VIEWS AND DETAILS
BA1603	HEADGATE VIEWS AND DETAILS

NOTES
1. SEE DRAWING BA151 FOR NOTES AND DRAWING BA150 FOR GENERAL NOTES.



FOR CONSTRUCTION ONLY

Submitted By	12/4/2025
TYLER W. BRAUN	12/3/2025
Approved By	
CUSHMAN 1 HEADGATE SEAL	
Drawn By: KJA	Construction Rev.

MACHINING TOLERANCES UNLESS OTHERWISE NOTED: FRACTIONAL ±1/64 DECIMAL ±.010 ANGLE ±1°		CITY OF TACOMA DEPARTMENT OF PUBLIC UTILITIES LIGHT DIVISION	
REV. NO. A		CUSHMAN 1 DAM HEADGATE SEAL VERTICAL MEMBER DETAILS	
SUBMITTED	DRAWN KJA	DATE	SCALE AS SHOWN
APPROVED	DRAWING NO. BA152		

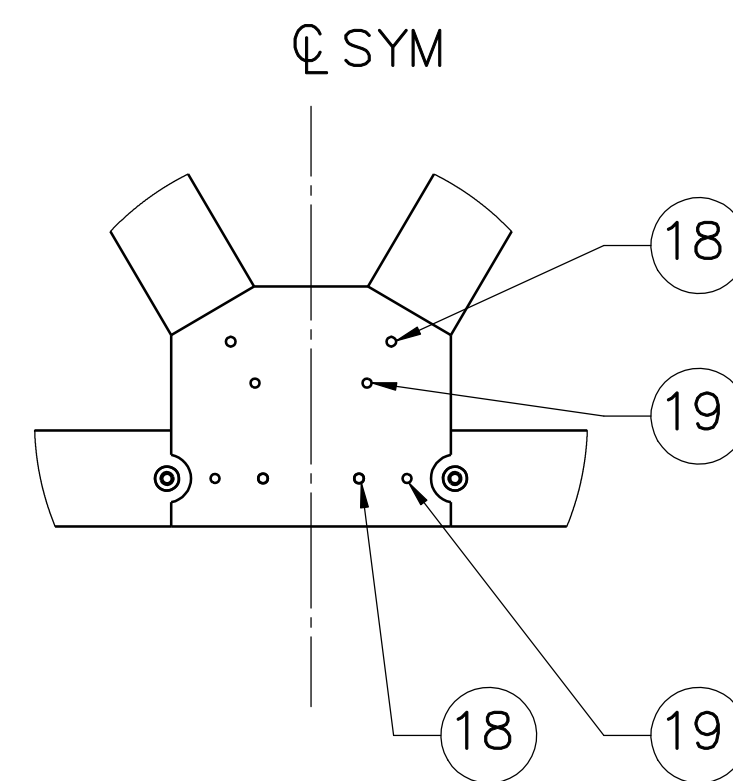
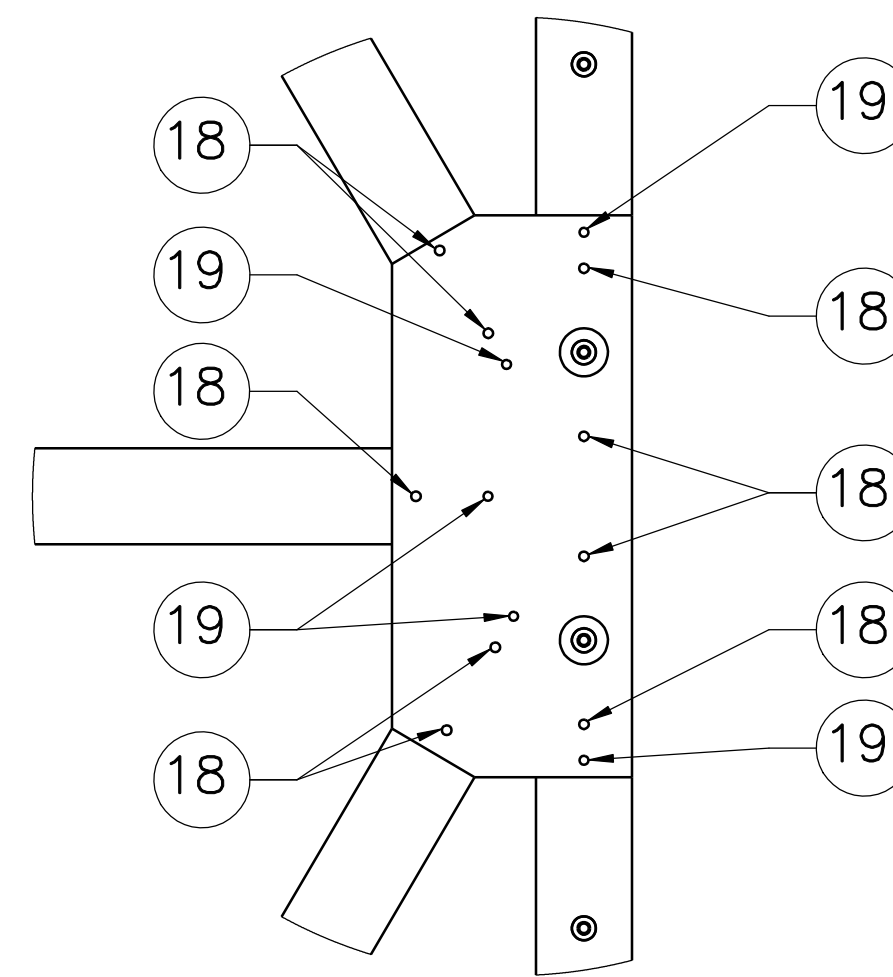
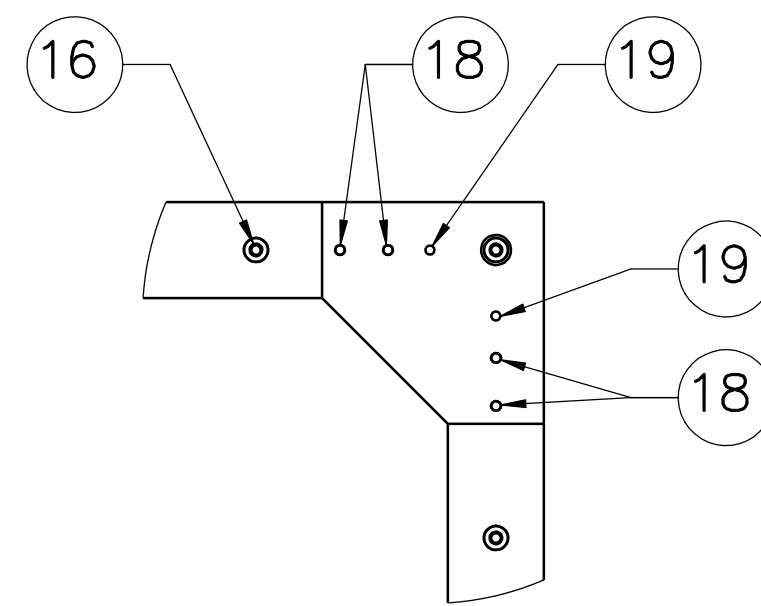
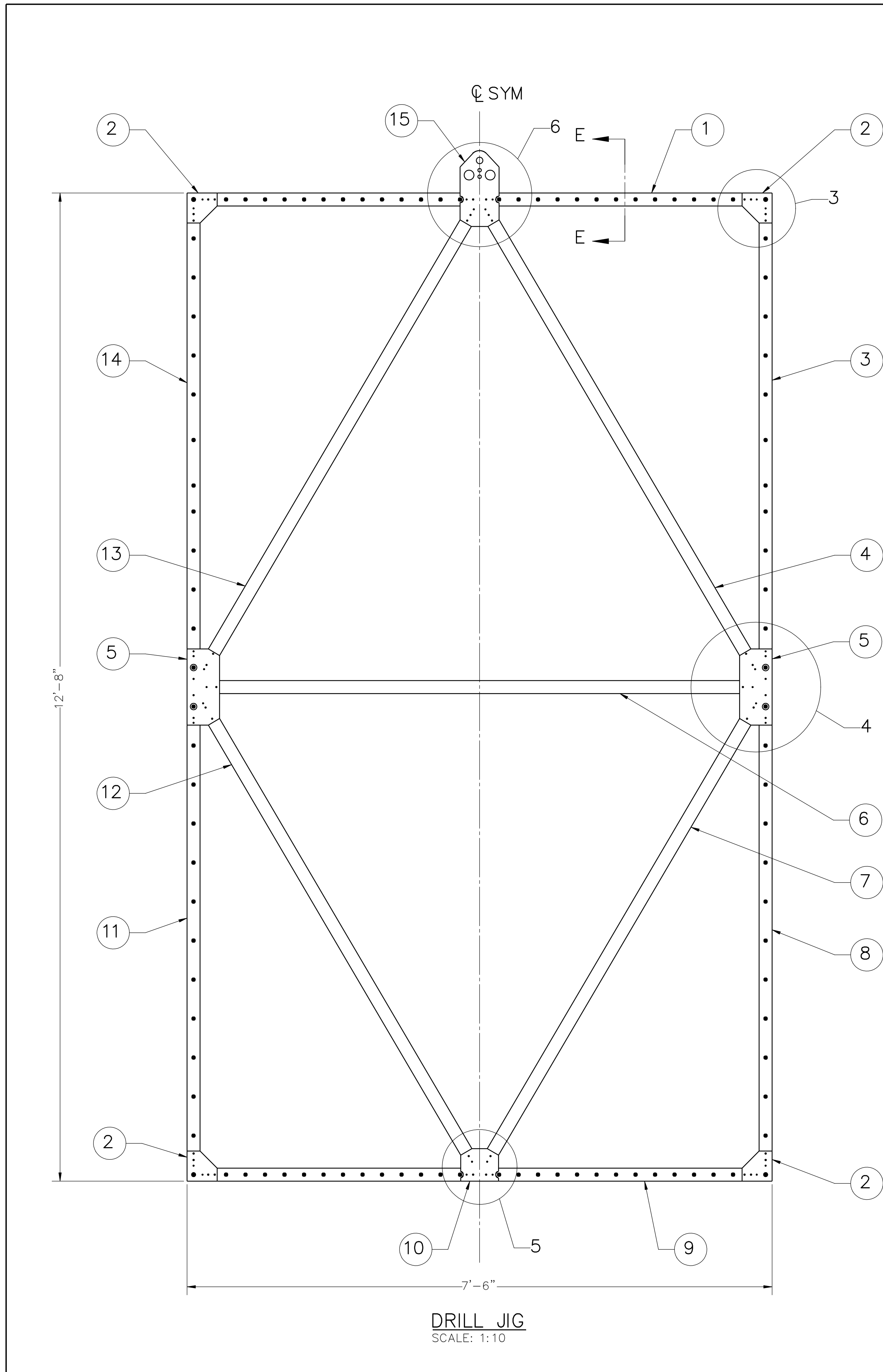

ITEM NO.	PART NUMBER	TITLE	DESCRIPTION	LENGTH	QTY.
1	BA153-1	TOP	FB 0.375 X 2	7'-2"	1
2	BA153-2	CORNER PLATE	FB 0.375 X 4 5/8	4 5/8"	4
3	BA153-3	UPPER RIGHT SIDE	FB 0.375 X 2	6'-4"	1
4	BA153-4	UPPER RIGHT BRACE	FB 0.1875 X 2	7'-0 3/4"	1
5	BA153-5	SIDE PLATE	FB 0.375 X 5	11 11/16"	2
6	BA153-6	MIDDLE BRACE	FB 0.1875 X 2	7'-2"	1
7	BA153-7	LOWER RIGHT BRACE	FB 0.1875 X 2	7'-0 3/4"	1
8	BA153-8	LOWER RIGHT SIDE	FB 0.375 X 2	6'-4"	1
9	BA153-9	BOTTOM	FB 0.375 X 2	7'-2"	1
10	BA153-10	BOTTOM PLATE	FB 0.375 X 5	5 13/16"	1
11	BA153-11	LOWER LEFT SIDE	FB 0.375 X 2	6'-4"	1
12	BA153-12	LOWER LEFT BRACE	FB 0.1875 X 2	7'-0 3/4"	1
13	BA153-13	UPPER LEFT BRACE	FB 0.1875 X 2	7'-0 3/4"	1
14	BA153-14	UPPER LEFT SIDE	FB 0.375 X 2	6'-4"	1
15	BA153-15	TOP PLATE	FB 0.375 X 6	11 5/8"	1
16	P-32-6-.2010	DRILL BUSHING, CARR LANE			104
17	BA153-17	JIG HANGER	FB 1 X 2.5	2 1/2"	1
18	#10-24 FHCS	82° X 7/8			44
19	BA153-19	"PULL OUT" DOWEL PIN ϕ 3/16 X 9/16			26
20	BA153-20	1/2-13UNC X 3 3/4 BOLT, NUT & WASHER TO SUIT			2

FASTENERS (5% EXTRA)

QTY.	DIA.	LENGTH	DESCRIPTION
47	#10-24	7/8"	82° FH SCREWS
28	3/16"	1	DOWEL PINS
47	#10-24	-	NUT
2	1/2-13	3 3/4"	HEX BOLT
2	1/2-13	-	NUT & WASHER

REFERENCE DRAWINGS

- BA150 HEADGATE SEAL ASSEMBLY, BOM AND DETAILS
- BA151 HEADGATE SEAL HORIZONTAL MEMBER DETAILS
- BA152 HEADGATE SEAL VERTICAL MEMBER DETAILS
- BA153-S1 to S4 HEADGATE SEAL DRILL JIG
- BA1601 HEADGATE ELEVATION VIEWS
- BA1602 HEADGATE SECTIONS, VIEWS AND DETAILS
- BA1603 HEADGATE VIEWS AND DETAILS

NOTES

1. MATCH MARK CONNECTING ITEMS.
2. SHOW ASSEMBLED JIG TO THE ENGINEER AS AN INSPECTION POINT PRIOR TO MACHINING PARTS BA150-1 THRU BA150-10. CONTACT STEVE BELVIN (253) 278-3416.
3. DISASSEMBLE FOR SHIPPING.
4. MATCH REAM ALL DOWEL PIN HOLES.
5. MATCH DRILL ALL FASTENER HOLES.

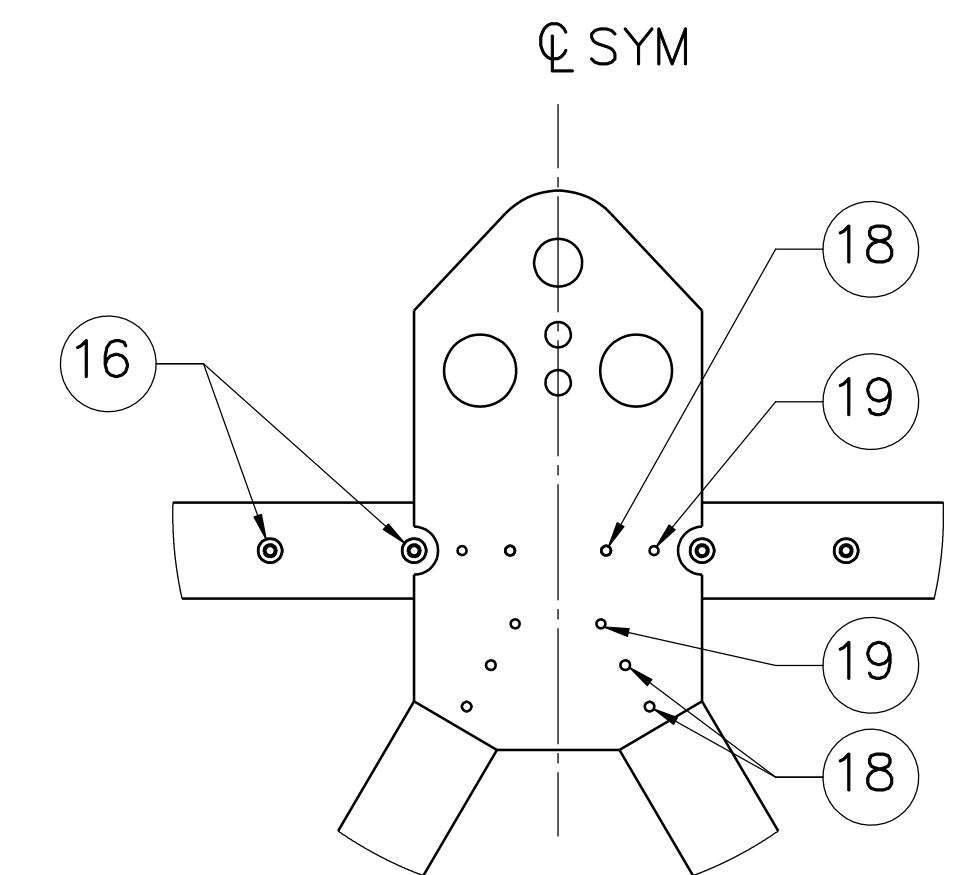
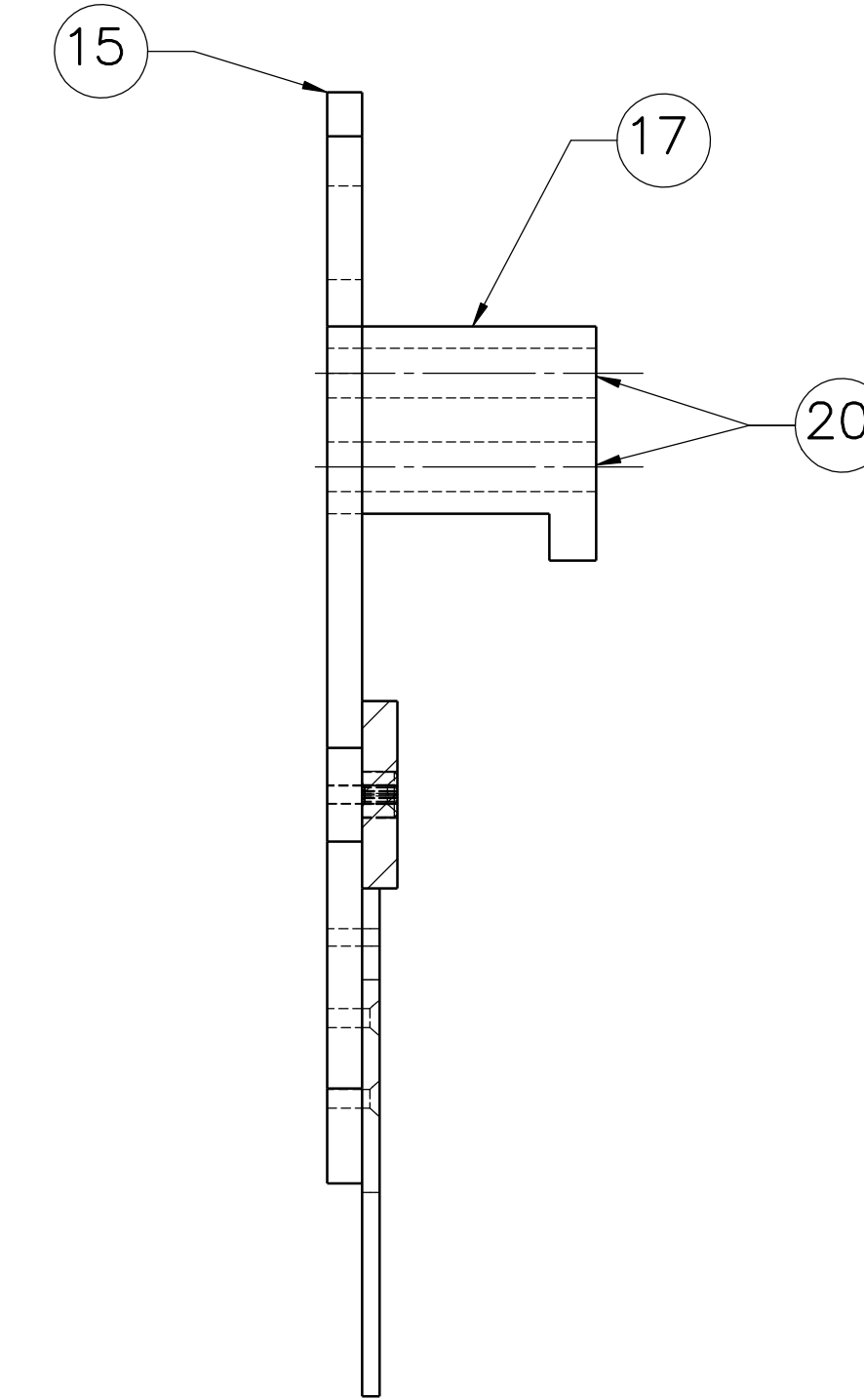

FOR CONSTRUCTION ONLY

Submitted By: BRAEDAN CAVELTI Date: 12/4/2025

Approved By: TYLER W BRAUN Date: 12/3/2025

CUSHMAN 1 HEADGATE SEAL

Drawn By: BC/KJA Construction Description: _____
Construction Rev: _____

MACHINING TOLERANCES UNLESS OTHERWISE NOTED: FRACTIONAL ±1/64 DECIMAL ±0.010 ANGLE ±1°		CITY OF TACOMA DEPARTMENT OF PUBLIC UTILITIES LIGHT DIVISION	
REV. NO. 0		CUSHMAN 1 DAM HEADGATE SEAL DRILL JIG ASSEMBLY & DETAILS	
SUBMITTED	DATE	DRAWN BC/KJA	STAMPED SCALE AS SHOWN
APPROVED	DATE	DRAWING NO. BA153-S1	

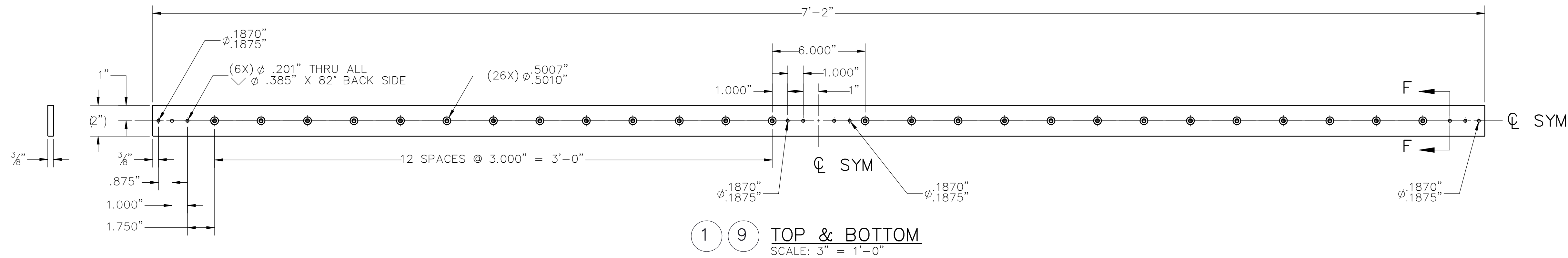

1 9 TOP & BOTTOM
SCALE: 3" = 1'-0"

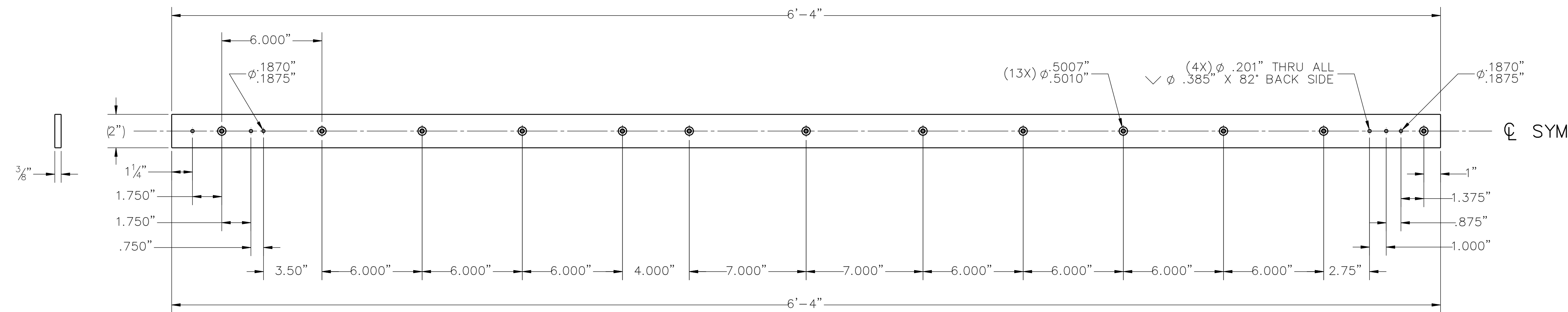
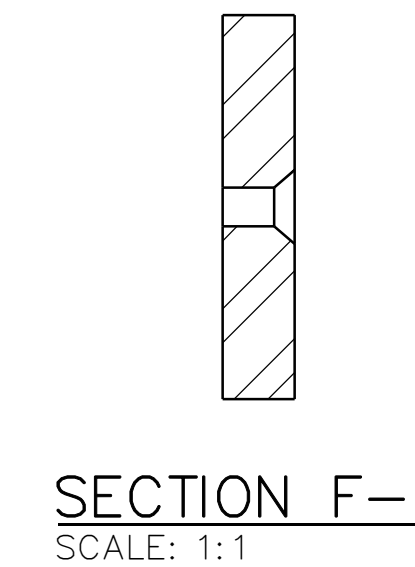

3 14 UPPER SIDES
SCALE: 3" = 1'-0"

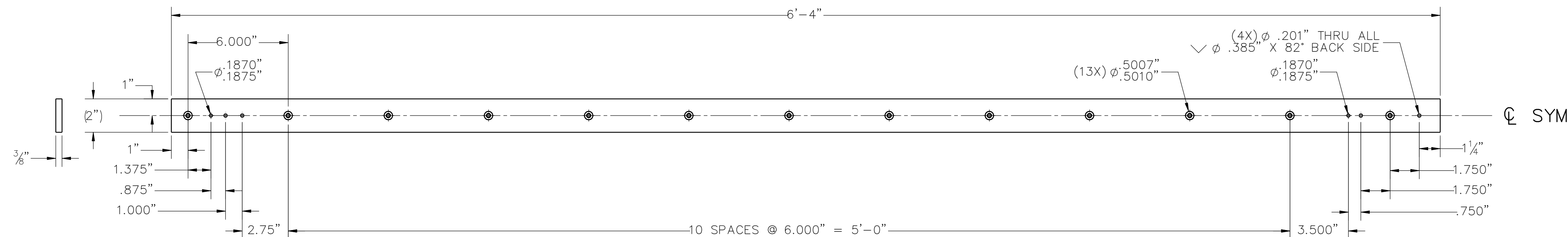

8 11 LOWER SIDES
SCALE: 3" = 1'-0"

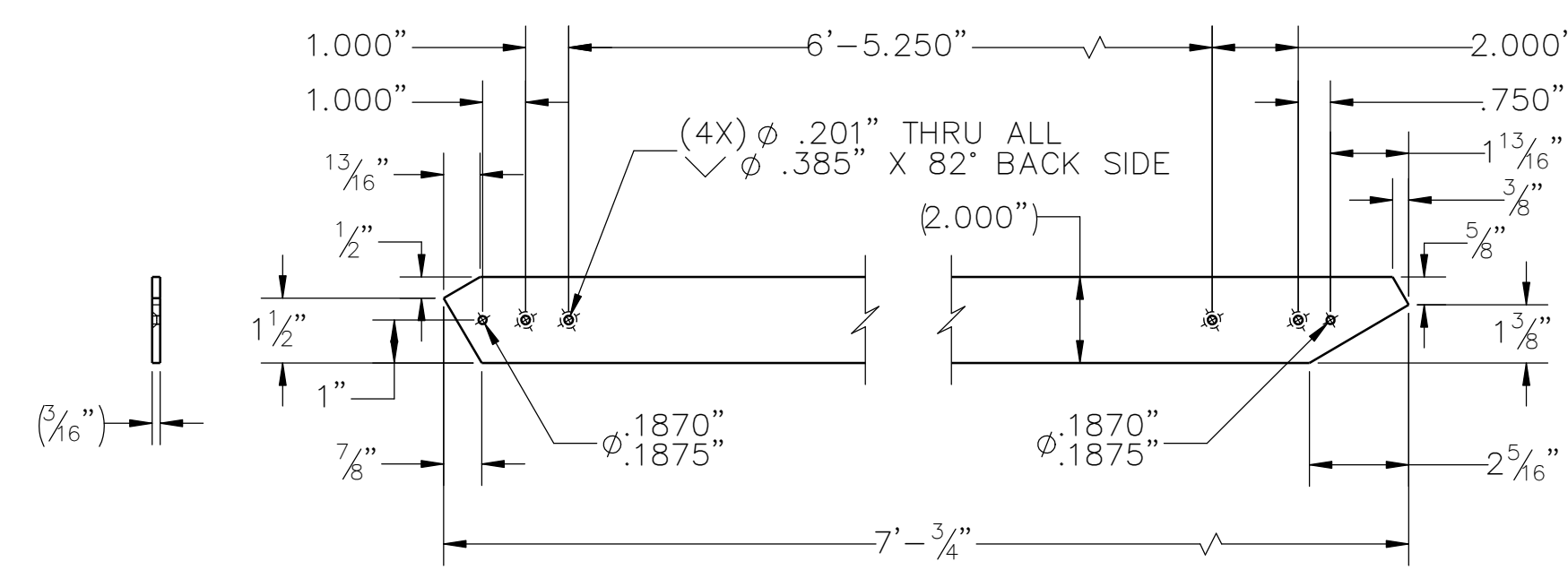

13 UPPER LEFT BRACE
SCALE: 3" = 1'-0"

4 UPPER RIGHT BRACE SIM, OP. HAND

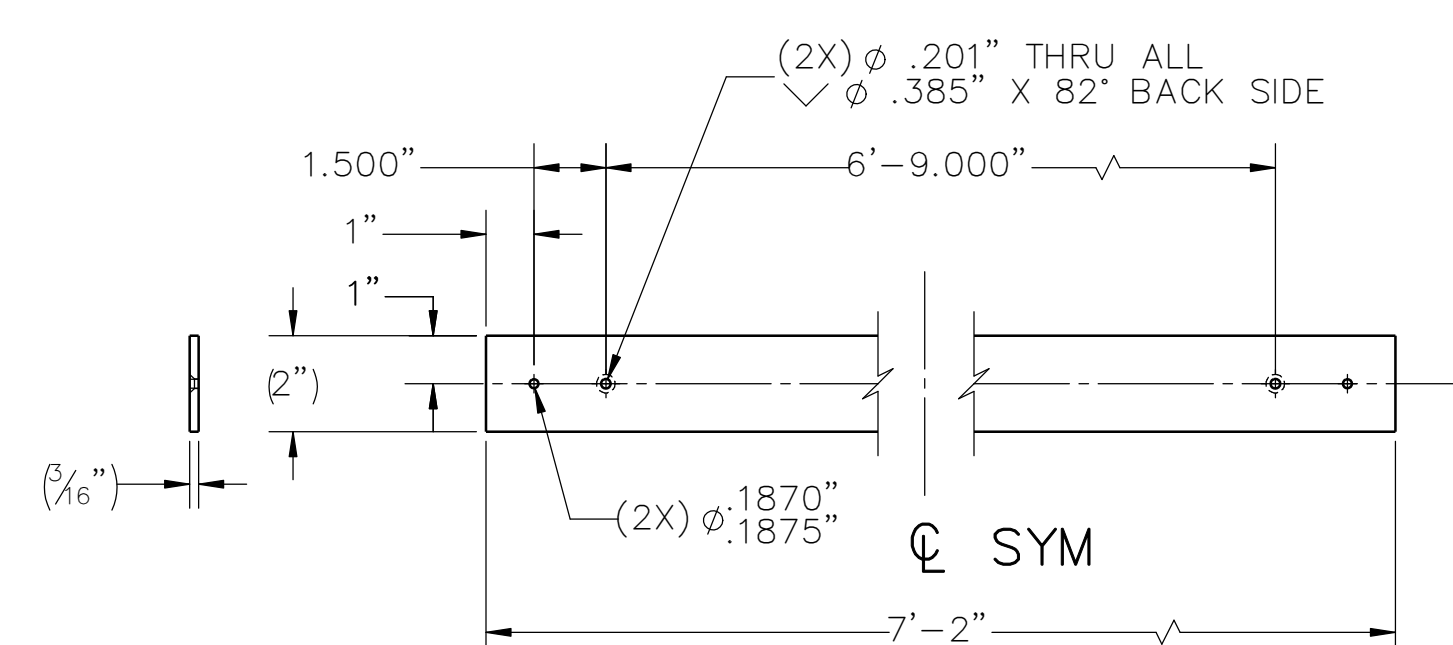

6 MIDDLE BRACE
SCALE: 3" = 1'-0"

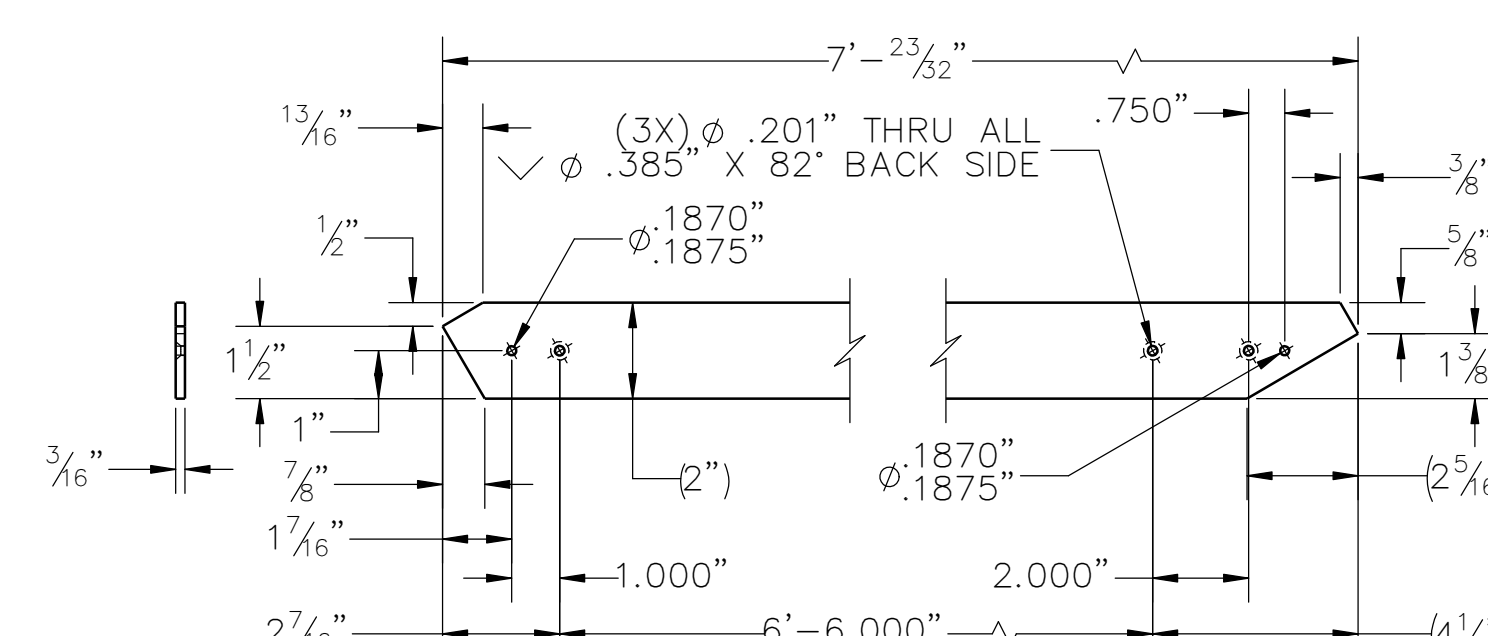

7 LOWER RIGHT BRACE
SCALE: 3" = 1'-0"

12 LOWER LEFT BRACE SIM, OP. HAND

REFERENCE DRAWINGS

- BA150 HEADGATE SEAL ASSEMBLY, BOM AND DETAILS
- BA151 HEADGATE SEAL HORIZONTAL MEMBER DETAILS
- BA152 HEADGATE SEAL VERTICAL MEMBER DETAILS
- BA153-S1 to S4 HEADGATE SEAL DRILL JIG
- BA1601 HEADGATE ELEVATION VIEWS
- BA1602 HEADGATE SECTIONS, VIEWS AND DETAILS
- BA1603 HEADGATE VIEWS AND DETAILS

NOTES

- MAKE NO SUBSTITUTIONS OR MODIFICATIONS WITHOUT APPROVAL OF THE ENGINEER.
- DEBURR & BREAK ALL SHARP EDGES AND CORNERS.
- MATERIAL: CARBON STEEL

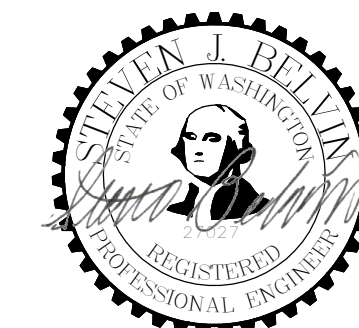

FOR CONSTRUCTION ONLY	
Submitted By: BRAADAN CAVELTI	Date: 12/4/2025
Approved By: TYLER W BRAUK	Date: 12/3/2025
CUSHMAN 1 HEADGATE SEAL	
Construction Description	
Drafted By: BC/KJA	Construction Rev: -

MACHINING TOLERANCES
UNLESS OTHERWISE NOTED:
FRACTIONAL ±1/64
DECIMAL ±0.010
ANGLE ±1°

CITY OF TACOMA
DEPARTMENT OF PUBLIC UTILITIES
LIGHT DIVISION

REV. NO. 0	CUSHMAN 1 DAM HEADGATE SEAL DRILL JIG ARMS & DETAILS	
SUBMITTED	DRAWN BC/KJA	STAMPED
APPROVED	DATE	SCALE AS SHOWN
DRAWING NO. BA153-S2		

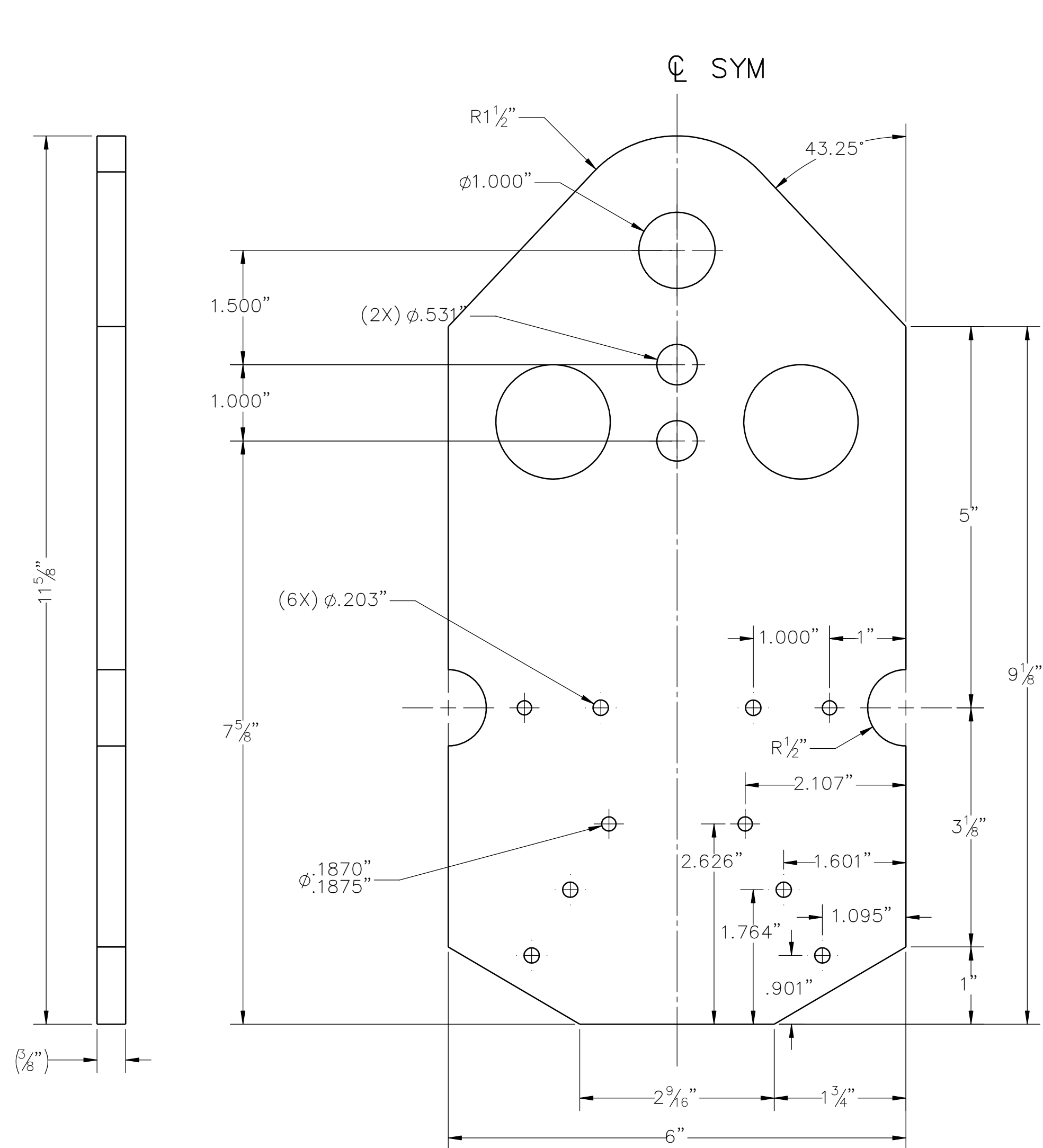

15 TOP PLATE
SCALE: 3/4" = 1"

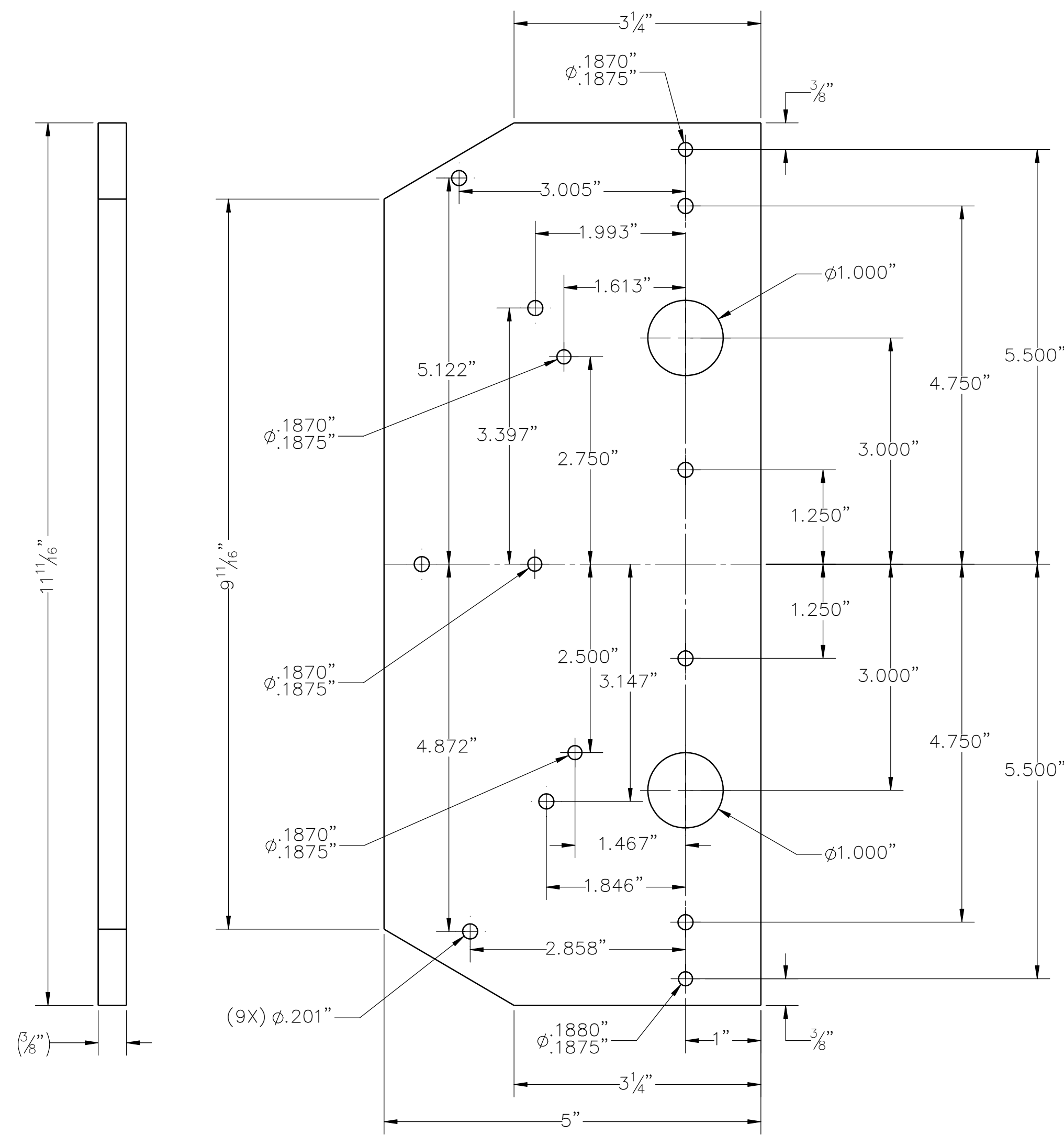

5 SIDE PLATE
SCALE: 3/4" = 1"

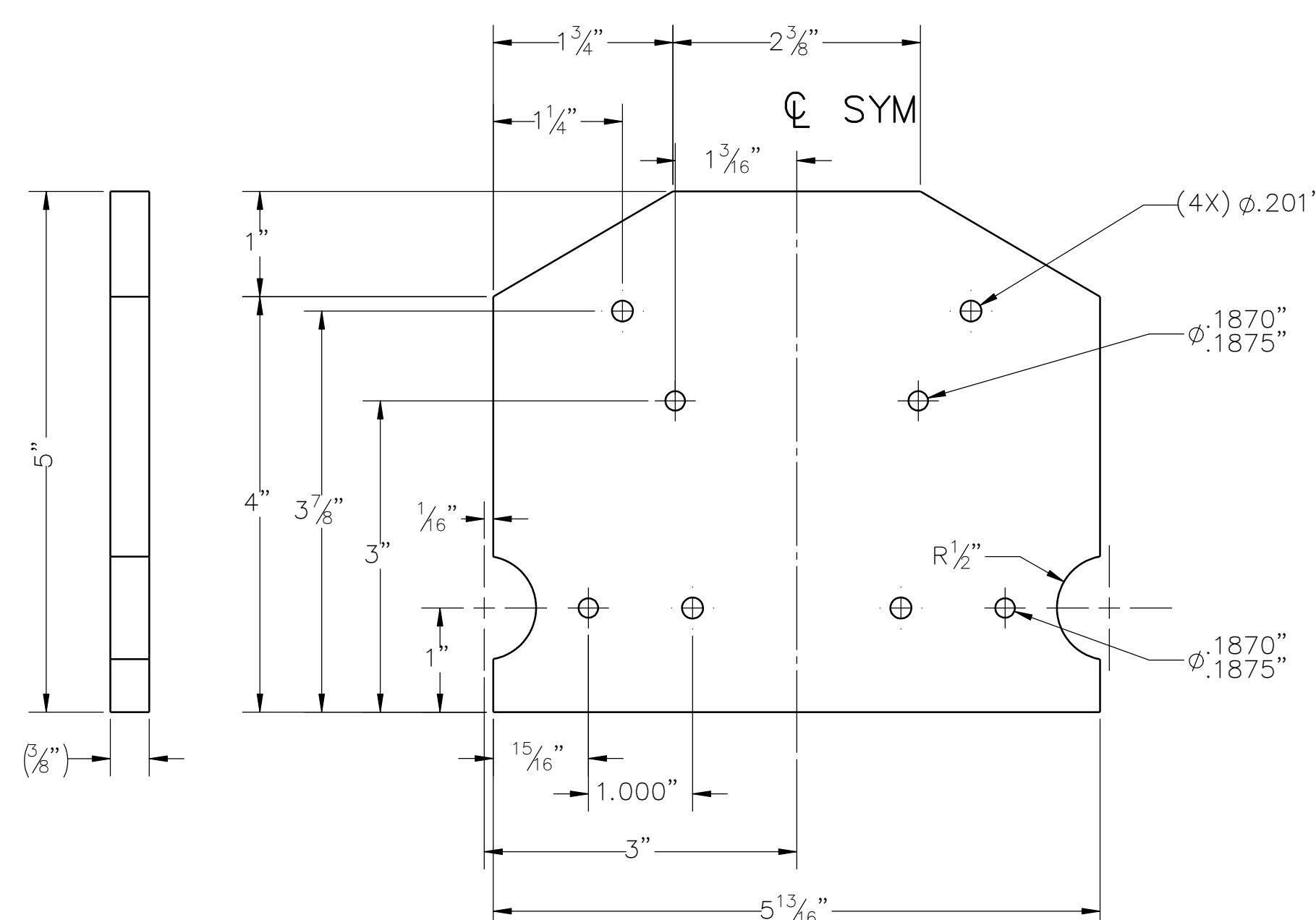

10 BOTTOM PLATE
SCALE: 3/4" = 1"

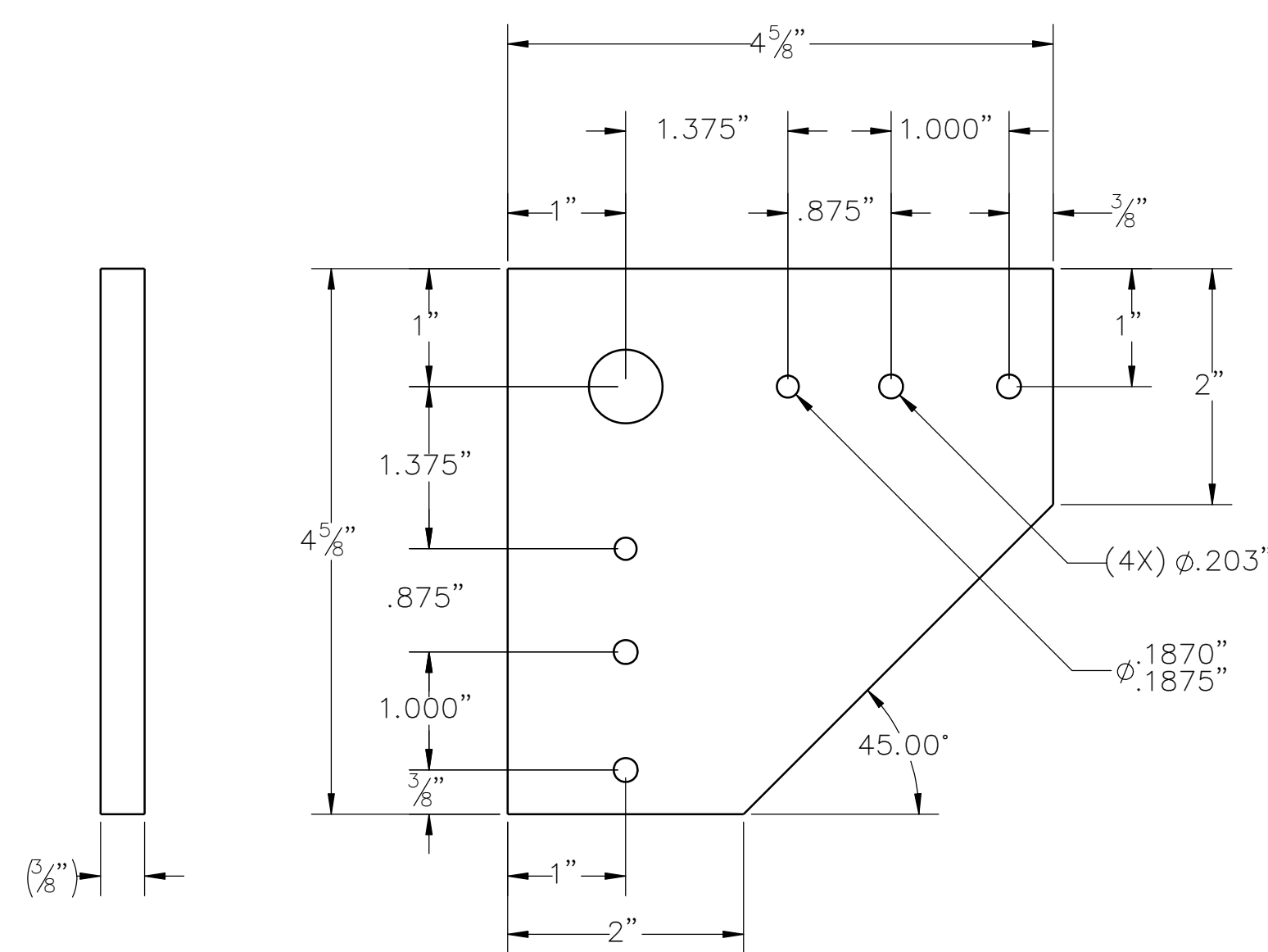

2 CORNER PLATE
SCALE: 3/4" = 1"

REFERENCE DRAWINGS

- BA150 HEADGATE SEAL ASSEMBLY, BOM AND DETAILS
- BA151 HEADGATE SEAL HORIZONTAL MEMBER DETAILS
- BA152 HEADGATE SEAL VERTICAL MEMBER DETAILS
- BA153-S1 to S4 HEADGATE SEAL DRILL JIG
- BA1601 HEADGATE ELEVATION VIEWS
- BA1602 HEADGATE SECTIONS, VIEWS AND DETAILS
- BA1603 HEADGATE VIEWS AND DETAILS

NOTES

1. MAKE NO SUBSTITUTIONS OR MODIFICATIONS WITHOUT APPROVAL OF THE ENGINEER.
2. DEBURR & BREAK ALL SHARP EDGES AND CORNERS.
3. MATERIAL: CARBON STEEL

MACHINING TOLERANCES
UNLESS OTHERWISE NOTED:
FRACTIONAL ±1/64
DECIMAL ±0.010
ANGLE ±1°

CITY OF TACOMA
DEPARTMENT OF PUBLIC UTILITIES
LIGHT DIVISION

REV. NO. 0

CUSHMAN 1 DAM
HEADGATE SEAL
DRILL JIG
BRACING DETAILS

SUBMITTED	DRAWN BC/KJA	STAMPED
DATE	SCALE AS SHOWN	
APPROVED		

DRAWING NO.
BA153-S3



FOR CONSTRUCTION ONLY
Submitted By: BRAEDAN CAVELTI 12/4/2025
Approved By: TYLER W BRAUN 12/3/2025
CUSHMAN 1 HEADGATE SEAL
Drafted By: BC/KJA Construction Rev. -

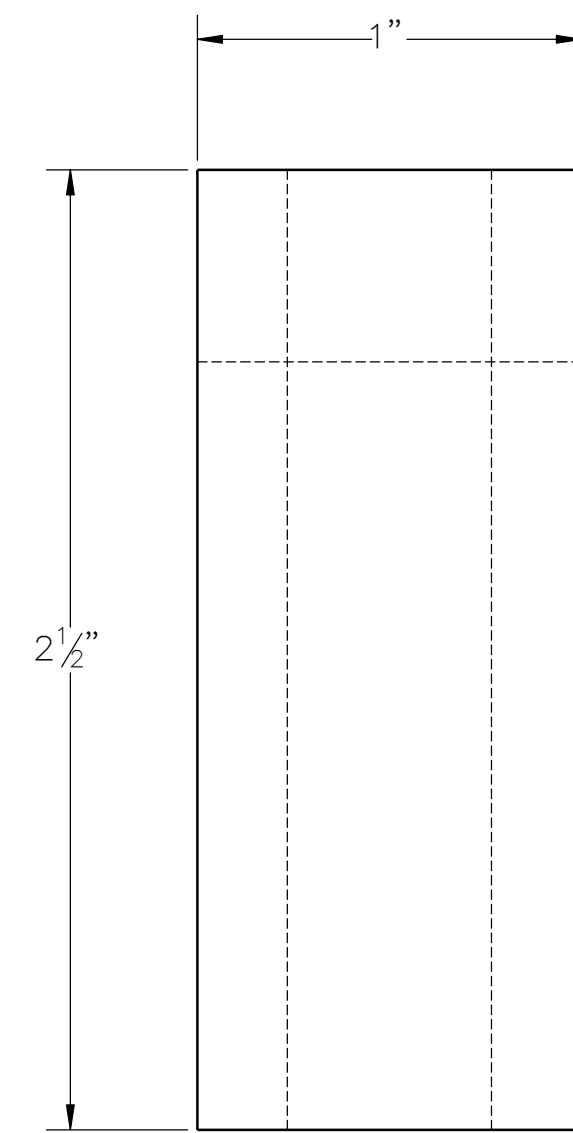

TOP VIEW
SCALE: 2:1

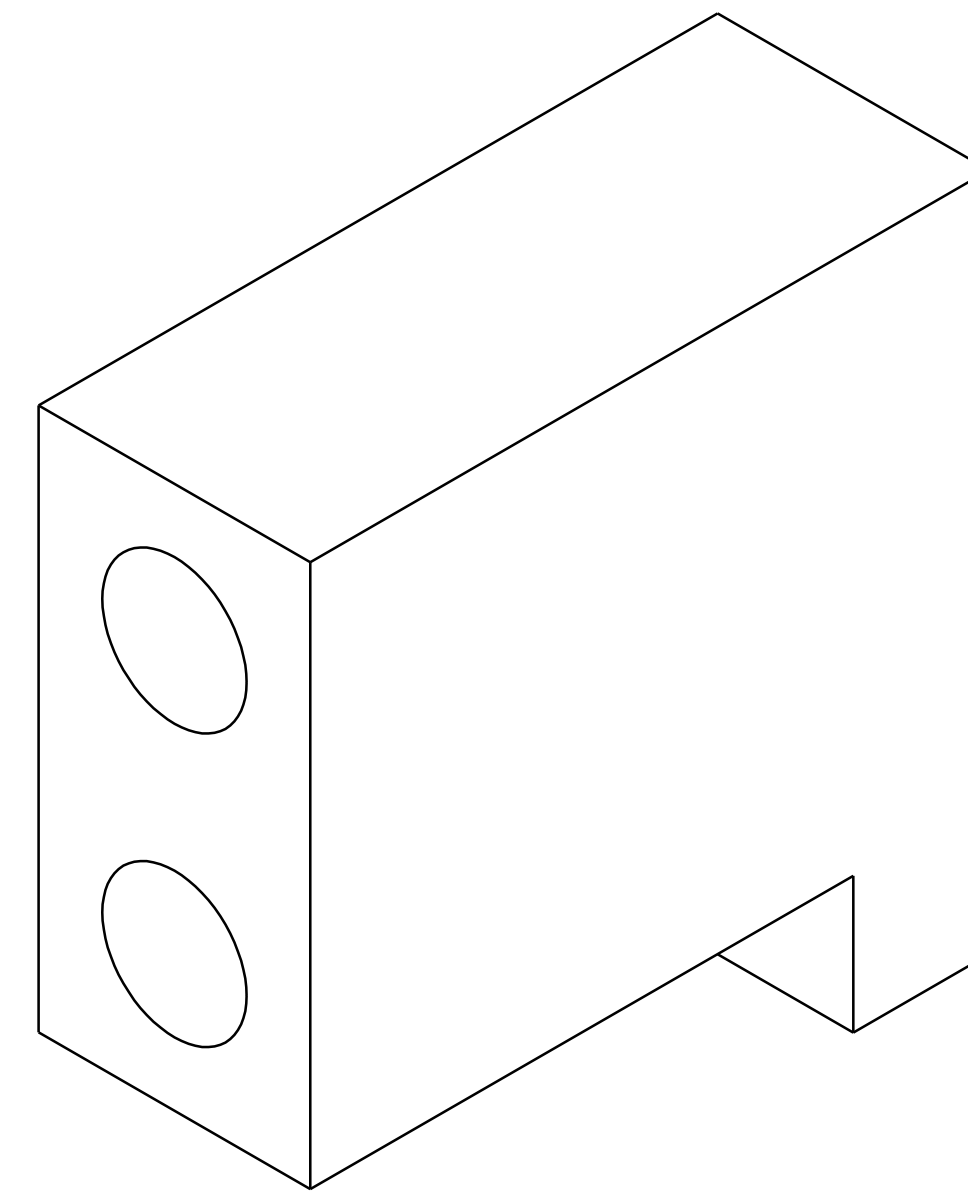

ISO VIEW
SCALE: 2:1

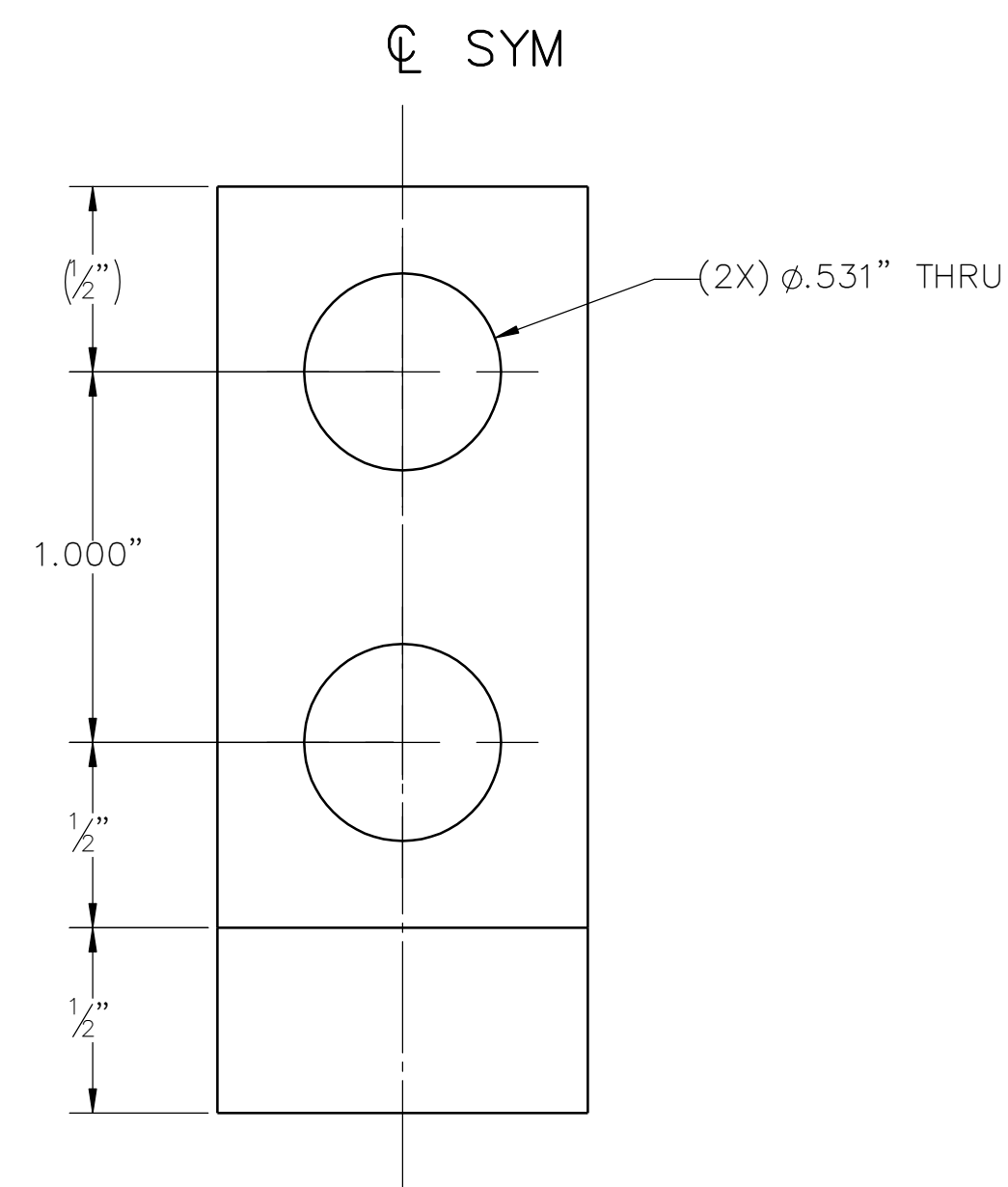

17 JIG HANGER
SCALE: 2:1

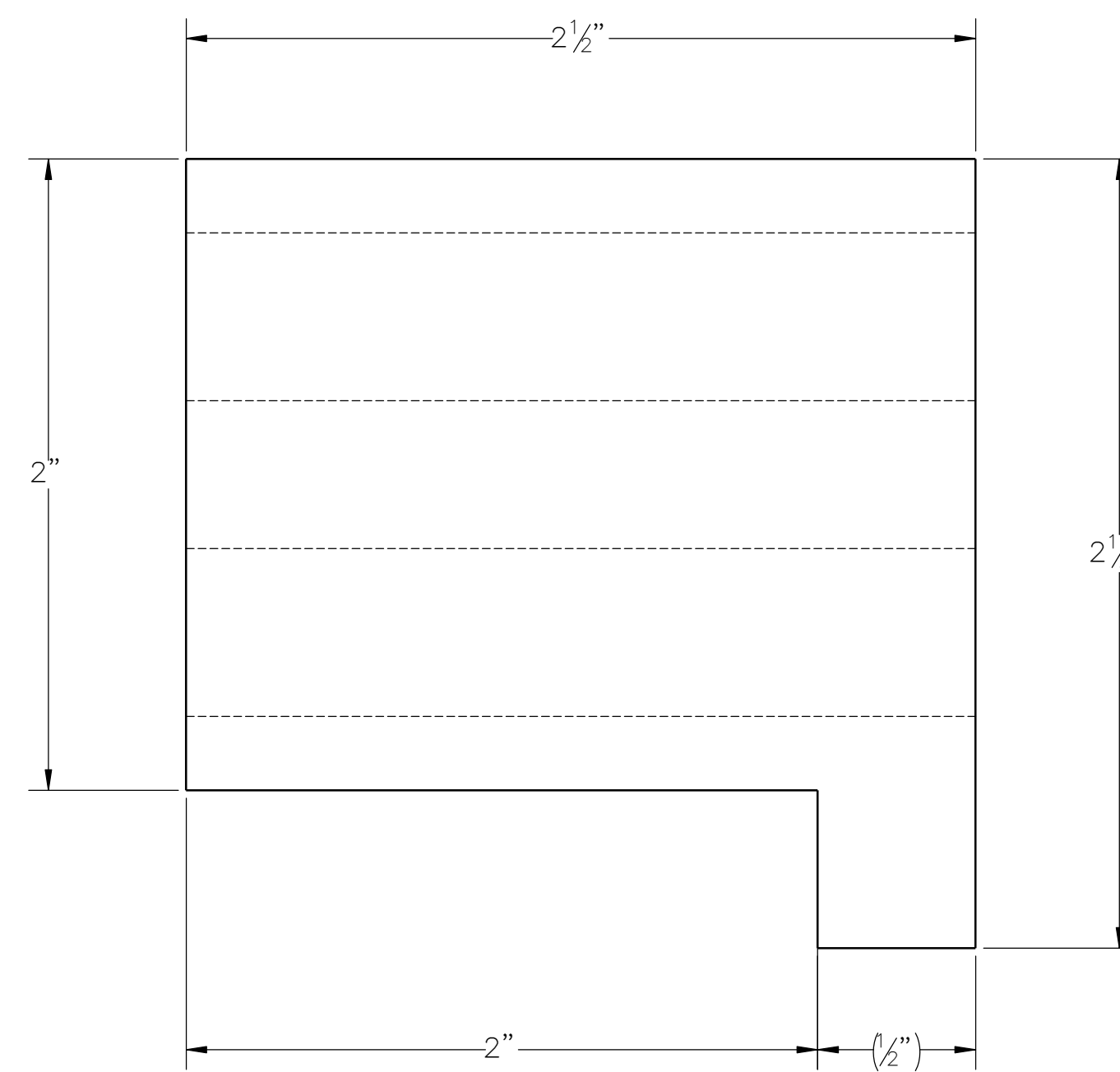

RIGHT VIEW
SCALE: 2:1

REFERENCE DRAWINGS

BA150	HEADGATE SEAL ASSEMBLY, BOM AND DETAILS
BA151	HEADGATE SEAL HORIZONTAL MEMBER DETAILS
BA152	HEADGATE SEAL VERTICAL MEMBER DETAILS
BA153-S1 to S4	HEADGATE SEAL DRILL JIG
BA1601	HEADGATE ELEVATION VIEWS
BA1602	HEADGATE SECTIONS, VIEWS AND DETAILS
BA1603	HEADGATE VIEWS AND DETAILS

NOTES

1. MAKE NO SUBSTITUTIONS OR MODIFICATIONS WITHOUT APPROVAL OF THE ENGINEER.
2. DEBURR & BREAK ALL SHARP EDGES AND CORNERS.
3. MATERIAL: CARBON STEEL

MACHINING TOLERANCES UNLESS OTHERWISE NOTED: FRACTIONAL ±1/64 DECIMAL ±0.010 ANGLE ±1°		CITY OF TACOMA DEPARTMENT OF PUBLIC UTILITIES LIGHT DIVISION	
REV. NO. 0		CUSHMAN 1 DAM HEADGATE SEAL DRILL JIG HANGER	
SUBMITTED	DATE	DRAWN BC/KJA	STAMPED
APPROVED	DATE	SCALE AS SHOWN	
		DRAWING NO. BA153-S4	



FOR CONSTRUCTION ONLY	
Submitted By BRAEDAN CAVELTI	Date 12/4/2025
Approved By TYLER W BRAUN	Date 12/3/2025
Construction Description CUSHMAN 1 HEADGATE SEAL	
Drafted By: BC/KJA	Construction Rev. =

APPENDIX B

Signature Page

Price Proposal Form

Record of Prior Contracts Form

SIGNATURE PAGE

**CITY OF TACOMA
TACOMA POWER/GENERATION**

All submittals must be in ink or typewritten, executed by a duly authorized officer or representative of the bidding/proposing entity, and received and time stamped as directed in the **Request for Bids page near the beginning of the specification**. If the bidder/proposer is a subsidiary or doing business on behalf of another entity, so state, and provide the firm name under which business is hereby transacted.

**REQUEST FOR BIDS SPECIFICATION NO. PG25-0263N
CUSHMAN NO. 1 HEADGATE SEAL AND DRILL JIG**

The undersigned bidder/proposer hereby agrees to execute the proposed contract and furnish all materials, labor, tools, equipment and all other facilities and services in accordance with these specifications.

The bidder/proposer agrees, by submitting a bid/proposal under these specifications, that in the event any litigation should arise concerning the submission of bids/proposals or the award of contract under this specification, Request for Bids, Request for Proposals or Request for Qualifications, the venue of such action or litigation shall be in the Superior Court of the State of Washington, in and for the County of Pierce.

Non-Collusion Declaration

The undersigned bidder/proposer hereby certifies under penalty of perjury that this bid/proposal is genuine and not a sham or collusive bid/proposal, or made in the interests or on behalf of any person or entity not herein named; and that said bidder/proposer has not directly or indirectly induced or solicited any contractor or supplier on the above work to put in a sham bid/proposal or any person or entity to refrain from submitting a bid/proposal; and that said bidder/proposer has not, in any manner, sought by collusion to secure to itself an advantage over any other contractor(s) or person(s).

Bidder/Proposer's Registered Name

Signature of Person Authorized to Enter Date
into Contracts for Bidder/Proposer

Address

Printed Name and Title

City, State, Zip

(Area Code) Telephone Number / Fax Number

Authorized Signatory E-Mail Address

State Business License Number
in WA, also known as UBI (Unified Business Identifier) Number

E.I.No. / Federal Social Security Number Used on Quarterly
Federal Tax Return, U.S. Treasury Dept. Form 941

State Contractor's License Number
(See Ch. 18.27, R.C.W.)

E-Mail Address for Communications

Addendum acknowledgement #1 _____ #2 _____ #3 _____ #4 _____ #5 _____

THIS PAGE MUST BE SIGNED AND RETURNED WITH SUBMITTAL.

Name of Bidder

PROPOSAL

	<u>QUANTITY</u>	<u>BID UNIT</u>	<u>UNIT COST</u>	<u>TOTAL COST</u>
<u>ITEM 1</u>				
Headgate Seal Assembly Per Drawing BA150	2	EA	\$ _____	\$ _____
<u>ITEM 2</u>				
Headgate Seal Drill Jig Per Drawing BA153	1	EA	\$ _____	\$ _____
TOTAL ITEMS 1 - 2				\$ _____
**Sales Tax @ _____				\$ _____
TOTAL AMOUNT				\$ _____

APPENDIX C

Sample Contract

CONTRACT

Resolution No.
Contract No.

This Contract is made and entered into effective as of [Month], [Day], [Year] (“Effective Date”) by and between the City of Tacoma, a Municipal Corporation of the State of Washington (“City”), and [supplier name as it appears in Ariba, including dbas or trade names] (“Contractor”).

That in consideration of the mutual promises and obligations hereinafter set forth the Parties hereto agree as follows:

- I. Contractor shall fully execute and diligently and completely perform all work and provide all services and deliverables described herein and in the items listed below each of which are fully incorporated herein and which collectively are referred to as “Contract Documents”:

 1. Specification No. [Spec Number] [Spec Title] together with all authorized addenda.
 2. Contractor’s submittal [or specifically described portions thereof] dated [Enter Submittal Date] submitted in response to Specification No. [Spec Number] [Spec Title].
 3. Describe with specific detail and list separately any other documents that will make up the contract (fee schedule, work schedule, authorized personnel, etc.) or any other additional items mutually intended to be binding upon the parties.

- II. If federal funds will be used to fund, pay or reimburse all or a portion of the services provided under the Contract, the terms and conditions set forth at this Appendix A are incorporated into and made part of this Contract and CONTRACTOR will comply with all applicable provisions of Appendix A and with all applicable federal laws, regulations, executive orders, policies, procedures, and directives in the performance of this Contract.

If CONTRACTOR’s receipt of federal funds under this Contract is as a sub-recipient, a fully completed Appendix B, “Sub-recipient Information and Requirements” is incorporated into and made part of this Contract.
- III. In the event of a conflict or inconsistency between the terms and conditions contained in this document entitled Contract and any terms and conditions contained the above referenced Contract Documents the following order of precedence applies with the first listed item being the most controlling and the last listed item the least controlling:
 1. Contract, inclusive of Appendices A and B.
 2. List remaining Contract Documents in applicable controlling order.
- IV. The Contract terminates on xxxxx, and may be renewed for xxxxxxxx
- V. The total price to be paid by City for Contractor’s full and complete performance hereunder, including during any authorized renewal terms, may not exceed:
\$[Dollar Amount], plus any applicable taxes.
- VI. Contractor agrees to accept as full payment hereunder the amounts specified herein and in Contract Documents, and the City agrees to make payments at the times and in the manner and upon the terms and conditions specified. Except as may be otherwise provided herein or in Contract Documents Contractor shall provide and bear the expense of all equipment, work and labor of any sort whatsoever that may be required for the transfer of materials and for constructing and completing the work and providing the services and deliverables required by this Contract.
- VII. The City’s preferred method of payment is by ePayables (Payment Plus), followed by credit card (aka procurement card), then Electronic Funds Transfer (EFT) by Automated Clearing House (ACH), then check or other cash equivalent. CONTRACTOR may be required to have the capability of accepting the City’s ePayables or credit card methods of payment. The City of Tacoma will not accept price changes or pay additional fees when ePayables (Payment Plus) or credit card is used. The City, in its sole discretion, will determine the method of payment for this Contract.

VIII. Failure by City to identify a deficiency in the insurance documentation provided by Contractor or failure of City to demand verification of coverage or compliance by Contractor with the insurance requirements contained in the Contract Documents shall not be construed as a waiver of Contractor's obligation to maintain such insurance.

IX. Contractor and for its heirs, executors, administrators, successors, and assigns, does hereby agree to the full performance of all the requirements contained herein and in Contract Documents.

It is further provided that no liability shall attach to City by reason of entering into this Contract, except as expressly provided herein.

IN WITNESS WHEREOF, the Parties hereto have accepted and executed this Contract, as of the Effective Date stated above, which shall be Effective Date for bonding purposes as applicable.

CITY OF TACOMA:

CONTRACTOR:

Signature:

Signature:

Name:

Name:

Title:

Title:

(City of Tacoma use only - blank lines are intentional)

Director of Finance: _____

Deputy/City Attorney (approved as to form): _____

Approved By: _____

Approved By: _____

Approved By: _____

Approved By: _____

Approved By: _____

Approved By: _____

**APPENDIX A
FEDERAL FUNDING**

1. Termination for Breach

CITY may terminate this Contract in the event of any material breach of any of the terms and conditions of this Contract if CONTRACTOR's breach continues in effect after written notice of breach and 30 days to cure such breach and fails to cure such breach.

2. Prevailing Wages

1. If federal, state, local, or any applicable law requires CONTRACTOR to pay prevailing wages in connection with this Contract, and CONTRACTOR is so notified by the CITY, then CONTRACTOR shall pay applicable prevailing wages and otherwise comply with the Washington State Prevailing Wage Act (RCW 39.12) in the performance of this Contract.
2. If applicable, a Schedule of Prevailing Wage Rates and/or the current prevailing wage determination made by the Secretary of Labor for the locality or localities where the Contract will be performed is made of part of the Contract by this reference. If prevailing wages apply to the Contract, CONTRACTOR and its subcontractors shall:
 - i. Be bound by and perform all transactions regarding the Contract relating to prevailing wages and the usual fringe benefits in compliance with the provisions of Chapter 39.12 RCW, as amended, the Washington State Prevailing Wage Act and/or the Davis-Bacon Act (40 U.S.C. 3141- 3144, and 3146-3148) and the requirements of 29 C.F.R. pt. 5 as may be applicable, including the federal requirement to pay wages not less than once a week.
 - ii. Ensure that no worker, laborer or mechanic employed in the performance of any part of the Contract shall be paid less than the prevailing rate of wage specified on that Schedule and/or specified in a wage determination made by the Secretary of Labor (unless specifically preempted by federal law, the higher of the Washington state prevailing wage or federal Davis-Bacon rate of wage must be paid.
 - iii. Immediately upon award of the Contract, contact the Department of Labor and Industries, Prevailing Wages section, Olympia, Washington and/or the federal Department of Labor, to obtain full information, forms and procedures relating to these matters. Per such procedures, a Statement of Intent to Pay Prevailing Wages and/or other or additional documentation required by applicable federal law, must be submitted by CONTRACTOR and its subcontractors to the CITY, in the manner requested by the CITY, prior to any payment by the CITY hereunder, and an Affidavit of Wages Paid and/or other or additional documentation required by federal law must be received or verified by the CITY prior to final Contract payment.

3. COPELAND ANTI-KICKBACK ACT

For Contracts subject to Davis Bacon Act the following clauses will be incorporated into the Contract:

- A. CONTRACTOR shall comply with 18 U.S.C. § 874, 40 U.S.C. § 3145, and the requirements of 29 C.F.R. pt. 3 as may be applicable, which are incorporated by reference into this Contract.
- B. CONTRACTOR or subcontractor shall insert in any subcontracts the clause above and such other clauses federal agencies may by appropriate instructions require, and also a clause requiring the subcontractors to include these clauses in any lower tier subcontracts.

The prime contractor shall be responsible for the compliance by any subcontractor or lower tier subcontractor with all of these Contract clauses.

- C. Breach. A breach of the contract clauses above may be grounds for termination of the contract, and for debarment as a contractor and subcontractor as provided in 29 C.F.R. § 5.12.

4. EQUAL EMPLOYMENT OPPORTUNITY

During the performance of this Contract, CONTRACTOR will not discriminate against any employee or applicant for employment because of race, color, religion, sex, sexual orientation, gender identity, or national origin. If the CONTRACTOR does over \$10,000 in business a year that is funded, paid or reimbursed with federal funds, CONTRACTOR will take specific and affirmative action to ensure that applicants are employed, and that employees are treated during employment without regard to their race, color, religion, sex, sexual orientation, gender identity, or national origin. Such action shall include, but not be limited to the following:

- A. Employment, upgrading, demotion, or transfer; recruitment or recruitment advertising; layoff or termination; rates of pay or other forms of compensation; and selection for training, including apprenticeship. CONTRACTOR agrees to post in conspicuous places, available to employees and applicants for employment, notices to be provided setting forth the provisions of this nondiscrimination clause.
- B. CONTRACTOR will, in all solicitations or advertisements for employees placed by or on behalf of the Contractor, state that all qualified applicants will receive consideration for employment without regard to race, color, religion, sex, sexual orientation, gender identity, or national origin.
- C. CONTRACTOR will not discharge or in any other manner discriminate against any employee or applicant for employment because such employee or applicant has inquired about, discussed, or disclosed the compensation of the employee or applicant or another employee or applicant. This provision shall not apply to instances in which an employee who has access to the compensation information of other employees or applicants as a part of such employee's essential job functions discloses the compensation of such other employees or applicants to individuals who do not otherwise have access to such information, unless such disclosure is in response to a formal complaint or charge, in furtherance of an investigation, proceeding, hearing, or action, including an investigation conducted by the employer, or is consistent with the Contractor's legal duty to furnish information.
- D. CONTRACTOR will send to each labor union or representative of workers with which he has a collective bargaining agreement or other contract or understanding, a notice to be provided advising the said labor union or workers' representatives of the contractor's commitments under this section, and shall post copies of the notice in conspicuous places available to employees and applicants for employment.
- E. CONTRACTOR will comply with all provisions of Executive Order 11246 of September 24, 1965, and of the rules, regulations, and relevant orders of the Secretary of Labor.
- F. In the event of CONTRACTOR's noncompliance with the nondiscrimination clauses of this contract or with any of the said rules, regulations, or orders, this Contract may be canceled, terminated, or suspended in whole or in part and the CONTRACTOR may be declared ineligible for further federally funded contracts in accordance with procedures

authorized in Executive Order 11246 of September 24, 1965, and such other sanctions may be imposed and remedies invoked as provided in Executive Order 11246 of September 24, 1965, or by rule, regulation, or order of the Secretary of Labor, or as otherwise provided by law.

- G. CONTRACTOR will include the portion of the sentence immediately preceding paragraph (A) and the provisions of paragraphs (A) through (G) in every subcontract or purchase order unless exempted by rules, regulations, or orders of the Secretary of Labor issued pursuant to section 204 of Executive Order 11246 of September 24, 1965, so that such provisions will be binding upon each subcontractor or vendor. CONTRACTOR will take such action with respect to any subcontract or purchase order as the administering agency may direct as a means of enforcing such provisions, including sanctions for noncompliance:

Provided, however, that in the event CONTRACTOR becomes involved in, or is threatened with, litigation with a subcontractor or vendor as a result of such direction by the administering agency, the CONTRACTOR may request the United States to enter into such litigation to protect the interests of the United States.

5. CONTRACT WORK HOURS AND SAFETY STANDARDS ACT

- A. Overtime requirements. Neither CONTRACTOR or subcontractor contracting for any part of the Contract work which may require or involve the employment of laborers or mechanics shall require or permit any such laborer or mechanic in any workweek in which he or she is employed on such work to work in excess of forty hours in such workweek unless such laborer or mechanic receives compensation at a rate not less than one and one-half times the basic rate of pay for all hours worked in excess of forty hours in such workweek.
- B. Violation; liability for unpaid wages; liquidated damages. In the event of any violation of the clause set forth in paragraph (3)(A) of this section the CONTRACTOR and any subcontractor responsible therefor shall be liable for the unpaid wages. In addition, such CONTRACTOR and subcontractor shall be liable to the United States (in the case of work done under contract for the District of Columbia or a territory, to such District or to such territory), for liquidated damages. Such liquidated damages shall be computed with respect to each individual laborer or mechanic, including watchmen and guards, employed in violation of the clause set forth in paragraph (3)(A) of this section, in the sum of \$27 for each calendar day on which such individual was required or permitted to work in excess of the standard workweek of forty hours without payment of the overtime wages required by the clause set forth in paragraph (3)(A) of this section.
- C. Withholding for unpaid wages and liquidated damages. The CITY shall upon its own action or upon written request of an authorized representative of the Department of Labor withhold or cause to be withheld, from any moneys payable on account of work performed by the CONTRACTOR or subcontractor under any such contract or any other Federal

contract with the same prime contractor, or any other federally-assisted contract subject to the Contract Work Hours and Safety Standards Act, which is held by the same prime contractor, such sums as may be determined to be necessary to satisfy any liabilities of such CONTRACTOR or sub-contractor for unpaid wages and liquidated damages as provided in the clause set forth in paragraph (3)(B) of this section.

- D. Subcontracts. The Contractor or subcontractor shall insert in any subcontracts the clauses set forth in paragraph (3)(A) through (D) of this section and also a clause requiring the subcontractors to include these clauses in any lower tier subcontracts. The prime CONTRACTOR shall be responsible for compliance by any subcontractor or lower tier subcontractor with the clauses set forth in paragraphs (3)(A) through (D) of this section.

6. CLEAN AIR ACT

- A. CONTRACTOR agrees to comply with all applicable standards, orders or regulations issued pursuant to the Clean Air Act, as amended, 42 U.S.C. § 7401 et seq.
- B. CONTRACTOR agrees to report each violation to the CITY and understands and agrees that the CITY will, in turn, report each violation as required to assure notification to the Federal Emergency Management Agency, and the appropriate Environmental Protection Agency Regional Office.

CONTRACTOR agrees to include these requirements in each subcontract exceeding \$150,000 financed in whole or in part with federal funds.

7. FEDERAL WATER POLLUTION CONTROL ACT

- A. CONTRACTOR agrees to comply with all applicable standards, orders, or regulations issued pursuant to the Federal Water Pollution Control Act, as amended, 33 U.S.C. 1251 et seq.
- B. CONTRACTOR agrees to report each violation to the CITY and understands and agrees that the CITY will, in turn, report each violation as required to assure notification to the appropriate federal agency.
- C. CONTRACTOR agrees to include these requirements in each subcontract exceeding \$150,000 financed in whole or in part with federal funding.

8. DEBARMENT AND SUSPENSION

- A. This Contract is a Covered Transaction for purposes of 2 C.F.R. pt. 180 and 2 C.F.R. pt. 3000. As such, the CONTRACTOR is required to verify that none of the contractor's principals (defined at 2 C.F.R. § 180.995) or its affiliates (defined at 2 C.F.R. § 180.905) are excluded (defined at 2 C.F.R. § 180.940) or disqualified (defined at 2 C.F.R. § 180.935).
- B. CONTRACTOR must comply with 2 C.F.R. pt. 180, subpart C and 2 C.F.R. pt. 3000, subpart C, and must include a requirement to comply with these regulations in any lower tier Covered Transaction it enters into.

- C. This certification is a material representation of fact relied upon by the CITY. If it is later determined that the CONTRACTOR did not comply with 2 C.F.R. pt. 180, subpart C and 2 C.F.R. pt. 3000, subpart C, in addition to remedies available to CITY, the Federal Government may pursue available remedies, including but not limited to suspension and/or debarment.
- D. CONTRACTOR agrees to comply with the requirements of 2 C.F.R. pt. 180, subpart C and 2 C.F.R. pt. 3000, subpart C throughout the period of this Contract and to include a provision requiring such compliance in its lower tier covered transactions.

9. BYRD ANTI-LOBBYING AMENDMENT

- A. Contractors who apply or bid for an award of \$100,000 or more shall file the required certification with CITY. Each tier certifies to the tier above that it will not and has not used Federal appropriated funds to pay any person or organization for influencing or attempting to influence an officer or employee of any agency, a Member of Congress, officer or employee of Congress, or an employee of a Member of Congress in connection with obtaining any Federal contract, grant, or any other award covered by 31 U.S.C. § 1352. Each tier shall also disclose any lobbying with non-Federal funds that takes place in connection with obtaining any Federal award. Such disclosures are forwarded from tier to tier up to the recipient who in turn will forward the certification(s) to the CITY.
- B. If applicable, CONTRACTOR must sign and submit to the CITY the certification required by Appendix A to 44 CFR Part 18 contained at Appendix A-1 to this Contract.

10. PROCUREMENT OF RECOVERED MATERIALS

- A. In the performance of this Contract, CONTRACTOR shall make maximum use of products containing recovered materials that are EPA-designated items unless the product cannot be acquired:
 - i. Competitively within a timeframe providing for compliance with the contract performance schedule;
 - ii. Meeting contract performance requirements; or
 - iii. At a reasonable price.
- B. Information about this requirement, along with the list of EPA- designated items, is available at EPA's Comprehensive Procurement Guidelines web site, <https://www.epa.gov/smm/comprehensive-procurement-guideline-cpg-program>.
- C. CONTRACTOR also agrees to comply with all other applicable requirements of Section 6002 of the Solid Waste Disposal Act.

APPENDIX A-1

**APPENDIX A to 44 C.F.R. PART 18 – CERTIFICATION REGARDING LOBBYING
Certification for Contracts, Grants, Loans, and Cooperative Agreements**

The undersigned certifies, to the best of his or her knowledge and belief, that:

1. No Federal appropriated funds have been paid or will be paid, by or on behalf of the undersigned, to any person for influencing or attempting to influence an officer or employee of an agency, a Member of Congress, an officer or employee of Congress, or an employee of a Member of Congress in connection with the awarding of any Federal contract, the making of any Federal grant, the making of any Federal loan, the entering into of any cooperative agreement, and the extension, continuation, renewal, amendment, or modification of any Federal contract, grant, loan, or cooperative agreement.
2. If any funds other than Federal appropriated funds have been paid or will be paid to any person for influencing or attempting to influence an officer or employee of any agency, a Member of Congress, an officer or employee of Congress, or an employee of a Member of Congress in connection with this Federal contract, grant, loan, or cooperative agreement, the undersigned shall complete and submit Standard Form-LLL, "Disclosure Form to Report Lobbying," in accordance with its instructions.
3. The undersigned shall require that the language of this certification be included in the award documents for all subawards at all tiers (including subcontracts, subgrants, and contracts under grants, loans, and cooperative agreements) and that all subrecipients shall certify and disclose accordingly.

This certification is a material representation of fact upon which reliance was placed when this transaction was made or entered into. Submission of this certification is a prerequisite for making or entering into this transaction imposed by section 1352, title 31, U.S. Code. Any person who fails to file the required certification shall be subject to a civil penalty of not less than \$10,000 and not more than \$100,000 for each such failure.

The Contractor, _____, certifies or affirms the truthfulness and accuracy of each statement of its certification and disclosure, if any. In addition, the Contractor understands and agrees that the provisions of 31 U.S.C. Chap.38, Administrative Remedies for False Claims and Statements, apply to this certification and disclosure, if any.

Signature of Contractor's Authorized Official

Name and Title of Contractor's Authorized Official

Date

APPENDIX B—Sub-recipient information and requirements

Pursuant to 2 CFR 200.332(a)(1) Federal Award Identification

(i) Agency Name (must match the name associated with its unique entity identifier)		(ii) Unique Entity Identifier <i>(i.e., DUNS)</i>	City of Tacoma Number for This Agreement
(iii) Federal Award Identification Number (FAIN)	(iv) Federal Award Date	(v) Federal Period of Performance Start and End Date	(vi) Federal Budget Period Start and End Date
(vii) Amount of Federal Funds <i>Obligated</i> to the agency <i>by this action</i> : \$	(viii) Total Amount of Federal Funds <i>Obligated</i> to the agency	(ix) Total Amount of the Federal Award <i>Committed</i> to the agency \$	
(x) Federal Award Project Description: CORONAVIRUS STATE AND LOCAL FISCAL RECOVERY FUNDS– City of Tacoma			
(xi) Federal Awarding Agency: DEPARTMENT OF THE TREASURY	Pass-Through Entity: City of Tacoma	Awarding Official Name and Contact Information:	
(xii) Assistance Listing Number and Name (the pass-through entity must identify the dollar amount made available under each Federal award and the Assistance Listing number at time of disbursement)			(xiii) Identification of Whether the Award is R&D
(xiv) Indirect Cost Rate for the Federal Award	Award Payment Method (lump sum payment or reimbursement) REIMBURSEMENT		